



Designation: E237 – 02 (Reapproved 2024)

Standard Specification for Laboratory Glass Microvolumetric Vessels (Volumetric Flasks and Centrifuge Tubes)¹

This standard is issued under the fixed designation E237; the number immediately following the designation indicates the year of original adoption or, in the case of revision, the year of last revision. A number in parentheses indicates the year of last reapproval. A superscript epsilon (ϵ) indicates an editorial change since the last revision or reapproval.

1. Scope

1.1 This specification covers volumetric flasks and four types of centrifuge tubes, widely used in microchemistry.

NOTE 1—Specifications for several items listed below were developed by the Committee on Microchemical Apparatus, Division of Analytical Chemistry, American Chemical Society.²

1.2 Product with a stated capacity not listed in this standard may be specified Class A tolerance when product conforms to the tolerance range of the next smaller volumetric standard product listed in [Table 1](#).

1.3 *This international standard was developed in accordance with internationally recognized principles on standardization established in the Decision on Principles for the Development of International Standards, Guides and Recommendations issued by the World Trade Organization Technical Barriers to Trade (TBT) Committee.*

2. Referenced Documents

2.1 *ASTM Standards:*³

[E438 Specification for Glasses in Laboratory Apparatus](#)

[E542 Practice for Gravimetric Calibration of Laboratory Volumetric Instruments](#)

[E671 Specification for Maximum Permissible Thermal Residual Stress in Annealed Glass Laboratory Apparatus](#)

[E694 Specification for Laboratory Glass Volumetric Apparatus](#)

[E920 Specification for Commercially Packaged Laboratory Apparatus](#)

¹ This specification is under the jurisdiction of ASTM Committee E41 on Laboratory Apparatus and is the direct responsibility of Subcommittee E41.01 on Laboratory Ware and Supplies.

Current edition approved Feb. 1, 2024. Published February 2024. Originally approved in 1964. Last previous edition approved in 2019 as E237 – 02(2019). DOI: 10.1520/E0237-02R24.

² Committee on Microchemical Apparatus, Division of Analytical Chemistry, American Chemical Society, “Report on Recommended Specifications for Microchemical Apparatus. Volumetric Glassware: Flasks, Pipets, and Centrifuge Tubes,” *Analytical Chemistry*, Vol 28, 1956, p. 1993.

³ For referenced ASTM standards, visit the ASTM website, www.astm.org, or contact ASTM Customer Service at service@astm.org. For *Annual Book of ASTM Standards* volume information, refer to the standard’s Document Summary page on the ASTM website.

[E921 Specification for Export Packaged Laboratory Apparatus](#)

[E1133 Practice for Performance Testing of Packaged Laboratory Apparatus for United States Government Procurements](#)

[E1157 Specification for Sampling and Testing of Reusable Laboratory Glassware](#)

3. Volumetric Flasks

3.1 The volumetric flasks shall be of either Style I or Style II of [Fig. 1](#) and shall conform to the requirements of [Fig. 1](#) and [Table 1](#). Each flask shall be marked with the symbol “TC” (or “IN”), the capacity, “20 °C”, and a 16 mm² marking area. (All in an optional location on the flask.)

4. Centrifuge Tubes

4.1 Centrifuge tubes of four types shall conform to the requirements prescribed in [Tables 2-4](#) and [Figs. 2-5](#). The types shown fit into the metal shields supplied with commercially available centrifuges. Removal of the glass stoppers from the centrifuge tubes shown in [Fig. 3](#) and [Fig. 4](#) is advisable before centrifugation. The four types of centrifuge tubes specified are as follows:

4.1.1 Conical bottom, plain ([Fig. 2](#)).

4.1.2 Conical bottom, stoppered ([Fig. 3](#)).

4.1.3 Conical bottom, stoppered and graduated ([Fig. 4](#)).

4.1.4 Cylindrical bottom, plain ([Fig. 5](#)).

5. Sampling and Testing

5.1 Refer to Specification [E1157](#).

6. Calibration

6.1 Flasks and graduated tubes shall be calibrated in accordance with Practice [E542](#) and conform to applicable requirements of Specification [E694](#). Glass shall be Type I, Class A of Specification [E438](#) and annealing shall be in accordance with Specification [E671](#).

7. Packaging

7.1 Select from Specification [E920](#), Specification [E921](#), or Practice [E1133](#).

TABLE 1 Volumetric Flask (see Fig. 1)

Style	Capacity, mL	Class A/ Tolerance, ± mL	A, ID, max/mm	B, ID, ref/mm	C, max/mm	D, max/mm	Stopper No.
I	1	0.010	5.3	8.25	70	100	8
II	1	0.010	5.3	—	95	125	8
I	2	0.015	6.4	10.75	70	100	8
I	3	0.015	6.4	13.50	72	100	8
I	4	0.020	7.3	14.00	75	100	8
I	5	0.020	7.3	15.75	75	100	8
I	10	0.020	8.25	18.00	110	135	9
I	25	0.030	8.7	26.00	140	165	9

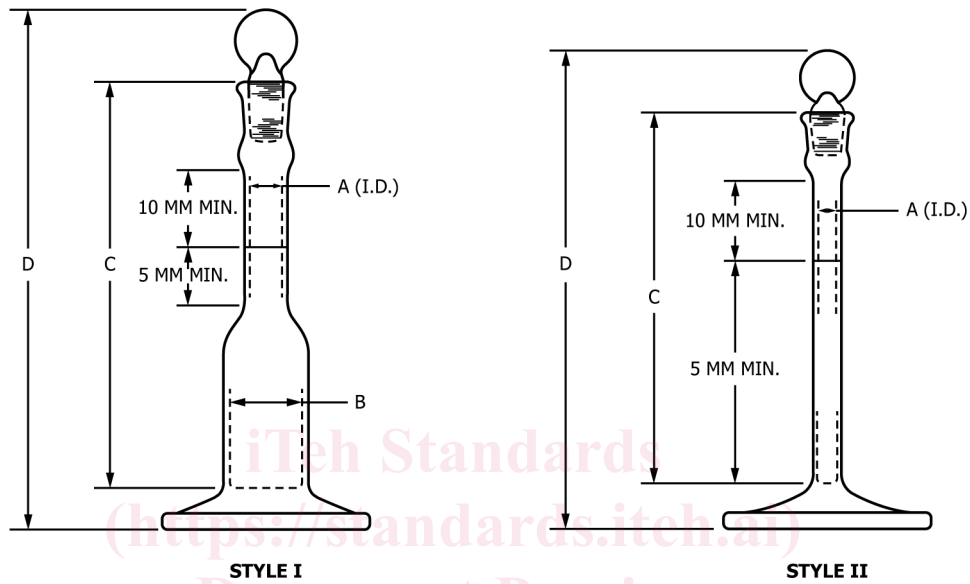

NOTE 1—The shape of the base may be either round or hexagonal

FIG. 1 Volumetric Flasks (see Table 1)

TABLE 2 Centrifuge Tubes, Conical Bottom, Plain (see Fig. 2)

Nominal Capacity, mL	A, Height, mm	B, OD Cylindrical Portion, mm	C, OD Top Finish, mm	D, Length of Taper, mm	E, OD at Bottom, mm
0.5	58 ± 2	6.0 ± 0.25	13.0 ± 1.0	30 ± 2	3.5 ± 0.5
1	61 ± 2	8.25 ± 0.25	13.0 ± 1.0	30 ± 2	3.5 ± 0.5
2	66 ± 2	10.75 ± 0.25	13.5 ± 1.0	30 ± 2	4.0 ± 0.5
3	74 ± 2	10.75 ± 0.25	13.5 ± 1.0	30 ± 2	4.0 ± 0.5
5	101 ± 2	13.00 ± 0.50	16.25 ± 0.75	40 ± 2	4.0 ± 0.5

8. Keywords

8.1 glass, laboratory; microvolumetric; vessels