



Designation: E2544 – 24

Standard Terminology for Three-Dimensional (3D) Imaging Systems¹

This standard is issued under the fixed designation E2544; the number immediately following the designation indicates the year of original adoption or, in the case of revision, the year of last revision. A number in parentheses indicates the year of last reappraisal. A superscript epsilon (ϵ) indicates an editorial change since the last revision or reappraisal.

1. Scope

1.1 This terminology contains common terms, definitions of terms, descriptions of terms, nomenclature, and acronyms associated with three-dimensional (3D) imaging systems in an effort to standardize terminology used for 3D imaging systems.

1.2 The definitions of the terms presented in 3.1 are obtained from various standard documents developed by various standards development organizations. The intent is not to change these universally accepted definitions but to gather, in a single document, terms and their definitions that may be used in current or future standards for 3D imaging systems.

1.2.1 In some cases, definitions of the same term from two standards have been presented to provide additional reference. The text in parentheses to the right of each defined term is the name (and, in some cases, the specific section) of the source of the definition associated with that term.

1.3 The definitions in 3.2 are specific terms developed by this committee for 3D imaging systems. Some terms may have generally accepted definitions in a particular community or are defined in existing standards. If there are conflicting definitions, our preference is to adapt (modify) the ISO standard (if available) for this standard.

1.4 A definition in this terminology is a statement of the meaning of a word or word group expressed in a single sentence with additional information included in notes or discussions.

1.5 *This standard does not purport to address all of the safety concerns, if any, associated with its use. It is the responsibility of the user of this standard to establish appropriate safety, health, and environmental practices and determine the applicability of regulatory limitations prior to use.*

NOTE 1—The subcommittee responsible for this standard will review definitions on a five-year basis to determine if the definition is still appropriate as stated. Revisions will be made when determined necessary.

¹ This terminology is under the jurisdiction of Committee E57 on 3D Imaging Systems and is the direct responsibility of Subcommittee E57.10 on Terminology. Current edition approved Jan. 1, 2024. Published February 2024. Originally approved in 2007. Last previous edition approved in 2019 as E2544 – 11a (2019)^{e1}. DOI: 10.1520/E2544-24.

1.6 *This international standard was developed in accordance with internationally recognized principles on standardization established in the Decision on Principles for the Development of International Standards, Guides and Recommendations issued by the World Trade Organization Technical Barriers to Trade (TBT) Committee.*

2. Referenced Documents

2.1 ASTM Standards:²

- E456 Terminology Relating to Quality and Statistics
- E2919 Test Method for Evaluating the Performance of Systems that Measure Static, Six Degrees of Freedom (6DOF), Pose
- E2938 Test Method for Evaluating the Relative-Range Measurement Performance of 3D Imaging Systems in the Medium Range
- E3124 Test Method for Measuring System Latency Performance of Optical Tracking Systems that Measure Six Degrees of Freedom (6DOF) Pose
- E3125 Test Method for Evaluating the Point-to-Point Distance Measurement Performance of Spherical Coordinate 3D Imaging Systems in the Medium Range
- E2807 Specification for 3D Imaging Data Exchange, Version 1.0

2.2 ASME Standard:³

- B89.4.19 Performance Evaluation of Laser Based Spherical Coordinate Measurement Systems

2.3 ISO Standard:⁴

- VIM International vocabulary of metrology -- Basic and general concepts and associated terms
- ISO 11146-1 Lasers and laser-related equipment — Test methods for laser beam widths, divergence angles and

² For referenced ASTM standards, visit the ASTM website, www.astm.org, or contact ASTM Customer Service at service@astm.org. For *Annual Book of ASTM Standards* volume information, refer to the standard's Document Summary page on the ASTM website.

³ Available from American Society of Mechanical Engineers (ASME), ASME International Headquarters, Three Park Ave., New York, NY 10016-5990, <http://www.asme.org>.

⁴ Available from American National Standards Institute (ANSI), 25 W. 43rd St., 4th Floor, New York, NY 10036, <http://www.ansi.org>.

beam propagation ratios — Part 1: Stigmatic and simple astigmatic beams

2.4 NIST/SEMATECH Standard.⁵

NIST/SEMATECH e-Handbook of Statistical Methods

3. Terminology

3.1 Definitions:

accuracy of measurement, *n*—closeness of the agreement between the result of a measurement and a true value of the measurand. (VIM 3.5)

DISCUSSION—

- (1) Accuracy is a qualitative concept.
- (2) The term “precision” should not be used for “accuracy.”

bias (of a measuring instrument), *n*—systematic error of the indication of a measuring instrument. (VIM 3.25)

DISCUSSION—

(1) The bias of a measuring instrument is normally estimated by averaging the error of indication over an appropriate number of repeated measurements.

bias, *n*—difference between the average or expected value of a distribution and the true value.

(NIST/SEMATECH e-Handbook)

DISCUSSION—

(1) In metrology, the difference between precision and accuracy is that measures of precision are not affected by bias, whereas accuracy measures degrade as bias increases.

calibration, *n*—set of operations that establish, under specified conditions, the relationship between values of quantities indicated by a measuring instrument or measuring system, or values represented by a material measure or a reference material, and the corresponding values realized by standards. (VIM 6.11)

DISCUSSION—

(1) The result of a calibration permits either the assignment of values of measurands to the indications or the determination of corrections with respect to indications.

(2) A calibration may also determine other metrological properties such as the effect of influence quantities.

(3) The result of a calibration may be recorded in a document, sometimes called a calibration certificate or a calibration report.

compensation, *n*—the process of determining systematic errors in an instrument and then applying these values in an error model that seeks to eliminate or minimize measurement errors. (ASME B89.4.19)

conventional true value (of a quantity), *n*—value attributed to a particular quantity and accepted, sometimes by convention, as having an uncertainty appropriate for a given purpose. (VIM 1.20)

DISCUSSION—

(1) Examples: (1) at a given location, the value assigned to the quantity realized by a reference standard may be taken as

a conventional true value and (2) the CODATA (1986) recommended value for the Avogadro constant, N_A : $6\,022\,136\,7 \times 10^{23} \text{ mol}^{-1}$.

(2) Conventional true value is sometimes called assigned value, best estimate of the value, conventional value, or reference value.

(3) Frequently, a number of results of measurements of a quantity is used to establish a conventional true value.

error (of measurement), *n*—result of a measurement minus a true value of the measurand. (VIM 3.10)

DISCUSSION—

(1) Since a true value cannot be determined, in practice, a conventional true value is used (see true value and conventional true value).

(2) When it is necessary to distinguish “error” from “relative error,” the former is sometimes called “absolute error of measurement.” This should not be confused with the “absolute value of error,” which is the modulus of error.

indicating (measuring) instrument, *n*—measuring instrument that displays an indication. (VIM 4.6)

DISCUSSION—

(1) Examples include analog indicating voltmeter, digital frequency meter, and micrometer.

(2) The display may be analog (continuous or discontinuous) or digital.

(3) Values of more than one quantity may be displayed simultaneously.

(4) A displaying measuring instrument may also provide a record.

limiting conditions, *n*—the manufacturer’s specified limits on the environmental, utility, and other conditions within which an instrument may be operated safely and without damage. (ASME B89.4.19)

DISCUSSION—

(1) The manufacturer’s performance specifications are not assured over the limiting conditions.

maximum permissible error (MPE), *n*—extreme values of an error permitted by specification, regulations, and so forth for a given measuring instrument. (VIM 5.21)

measurand, *n*—particular quantity subject to measurement. (VIM 2.6)

DISCUSSION—

(1) Example includes vapor pressure of a given sample of water at 20°C.

(2) The specification of a measurand may require statements about quantities such as time, temperature, and pressure.

precision, *n*—closeness of agreement between independent test results obtained under stipulated conditions. (ASTM E456)

DISCUSSION—

(1) Precision depends on random errors and does not relate to the true value or the specified value.

(2) The measure of precision is usually expressed in terms of imprecision and computed as a standard deviation of the test results. Less precision is reflected by a larger standard deviation.

⁵ Available from National Institute of Standards and Technology (NIST), 100 Bureau Dr., Stop 1070, Gaithersburg, MD 20899-1070, <http://www.nist.gov>. e-Handbook available at <http://www.itl.nist.gov/div898/handbook/>.

(3) “Independent test results” means results obtained in a manner not influenced by any previous result on the same or similar test object. Quantitative measures of precision depend critically on the stipulated conditions. Repeatability and reproducibility conditions are particular sets of extreme stipulated conditions.

precision, *n*—*in metrology*, the variability of a measurement process around its average value.

(NIST/SEMATECH e-Handbook)

DISCUSSION—

(1) Precision is usually distinguished from accuracy, the variability of a measurement process around the true value. Precision, in turn, can be decomposed further into short-term variation or repeatability and long-term variation or reproducibility.

random error, *n*—result of a measurement minus the mean that would result from an infinite number of measurements of the same measurand carried out under repeatability conditions. (VIM 3.13)

DISCUSSION—

(1) Random error is equal to error minus systematic error.
(2) Because only a finite number of measurements can be made, it is possible to determine only an estimate of random error.

rated conditions, *n*—manufacturer-specified limits on environmental, utility, and other conditions within which the manufacturer’s performance specifications are guaranteed at the time of installation of the instrument. (ASME B89.4.19)

relative error, *n*—error of measurement divided by a true value of the measurand. (VIM 3.12)

DISCUSSION—

(1) Since a true value cannot be determined, in practice a conventional true value is used.

repeatability (of results of measurements), *n*—closeness of the agreement between the results of successive measurements of the same measurand carried out under the same conditions of measurement. (VIM 3.6)

DISCUSSION—

(1) These conditions are called repeatability conditions.
(2) Repeatability conditions include: the same measurement procedure; the same observer; the same measuring instrument used under the same conditions; the same location; and repetition over a short period of time.

(3) Repeatability may be expressed quantitatively in terms of the dispersion characteristics of the results.

reproducibility (of results of measurements), *n*—closeness of the agreement between the results of measurements of the same measurand carried out under changed conditions of measurement. (VIM 3.7)

DISCUSSION—

(1) A value statement of reproducibility requires specification of the conditions changed.

(2) The changed conditions may include: principle of measurement; method of measurement; observer; measuring instrument; reference standard; location; conditions of use; and time.

(3) Reproducibility may be expressed quantitatively in terms of the dispersion characteristics of the results.

(4) Results are usually understood to be corrected results.

systematic error, *n*—mean that would result from an infinite number of measurements of the same measurand carried out under repeatability conditions minus a true value of the measurand. (VIM 3.14)

DISCUSSION—

(1) Systematic error is equal to error minus random error.
(2) Like true value, systematic error and its causes cannot be completely known.
(3) For a measuring instrument, see “bias.”

true value (of a quantity), *n*—value consistent with the definition of a given particular quantity. (VIM 1.19)

DISCUSSION—

(1) This is a value that would be obtained by a perfect measurement.
(2) True values are by nature indeterminate.
(3) The indefinite article “a,” rather than the definite article “the,” is used in conjunction with “true value” because there may be many values consistent with the definition of a given particular quantity.

uncertainty of measurement, *n*—parameter, associated with the result of a measurement, that characterizes the dispersion of the values that could reasonably be attributed to the measurand. (VIM 3.9)

DISCUSSION—

(1) The parameter may be, for example, a standard deviation (or a given multiple of it) or the half width of an interval having a stated level of confidence.
(2) Uncertainty of measurement comprises, in general, many components. Some of these components may be evaluated from the statistical distribution of the results of series of measurements and can be characterized by experimental standard deviations. The other components, which can also be characterized by standard deviations, are evaluated from assumed probability distributions based on experience or other information.
(3) It is understood that the result of the measurement is the best estimate of the value of the measurand, and that all components of uncertainty, including those arising from systematic effects, such as components associated with corrections and reference standards, contribute to the dispersion.

3.2 Definitions of Terms Specific to This Standard:

3D imaging system, *n*—a non-contact measurement system used to produce a 3D representation (for example, a point cloud or a mesh/polygonal model) of an object or a scene.

DISCUSSION—

(1) Some examples of a 3D imaging system are terrestrial laser scanners, optical range cameras (such as 3D range cameras), and structured light systems.

(2) 3D imaging systems are used to measure from relatively small-scale objects (such as a circuit board, a coin, a statue, or a manufactured part) to larger scale objects or scenes (such as buildings, bridges, and archeological sites).

(3) The principles of measurement used in these systems include, but are not limited to, time-of-flight, triangulation, and interferometry.

(4) A large number of 3D imaging system applications are concerned with measuring the external (or visible) surfaces of objects or scenes. However, some applications may require that sub-surface measurements also be considered (e.g., measuring terrain under snow and ice or measuring through glass).

(5) Examples of commonly-used names for certain types of 3D imaging systems include LiDAR, RGB-D camera, flash LiDAR, LADAR, laser line scanner, stereo camera, 3D sonar, and area scanner.

absolute pose, n —pose of an object in the coordinate frame of the system under test. **E2919**

angular increment, n —the angle, $\Delta\alpha$, between reported points, where $\Delta\alpha = \alpha_i - \alpha_{i-1}$, in either the azimuth or elevation directions (or a combination of both) with respect to the instrument’s internal frame of reference.

DISCUSSION—

(1) For scanning instruments, the angular increment may also be known as the angle step size.

azimuth angle, n —the angle between the orthogonal projection of the laser beam on a plane perpendicular to the vertical (standing) axis of the instrument and a fixed (reference) axis in that plane. **E3125**

backsight, n —measurement mode, where the target is measured with the laser beam emerging from the back-face of the instrument.

DISCUSSION—The back-face may be arbitrarily chosen or may be defined in terms of the zenith angle of the spinning prism mirror that

directs the laser beam. For example, the face of the instrument from which the laser beam emerges that corresponds to a zenith angle between 180° and 360° may be defined as the back-face.

DISCUSSION—See also **frontsight**.

E3125

backward compatibility, n —ability of a file reader to understand a file created by a writer of an older version of a file format standard. **E2807**

beam diameter (d_σ), n —for a laser beam with a circular irradiance pattern, the beam diameter is the extent of the irradiance distribution in a cross section of the laser beam (in a plane orthogonal to its propagation path) at a distance z and is given by:

$$d_\sigma(z) = 4\sigma(z)$$

where:

$$\sigma(z) = \sigma_x(z) = \sigma_y(z)$$

$$\sigma_x(z), \sigma_y(z) = \text{the square roots of the second order moments}$$

DISCUSSION—

(1) Reference ISO 11146–1.

(2) For a laser beam with a Gaussian distribution of irradiance, the beam diameter is often defined as the distance across the center of the beam for which the irradiance, I , equals $1/e^2$ of the maximum irradiance (where e is the base of the natural logarithm). See Fig. 1. The area inside a circle with this diameter and centered at the beam center will contain 86.5 % of the total irradiance of the beam.

(3) The beam diameter may be expressed as X mm measured at Y m. To determine the beam diameter for any other distance, additional parameters are necessary.

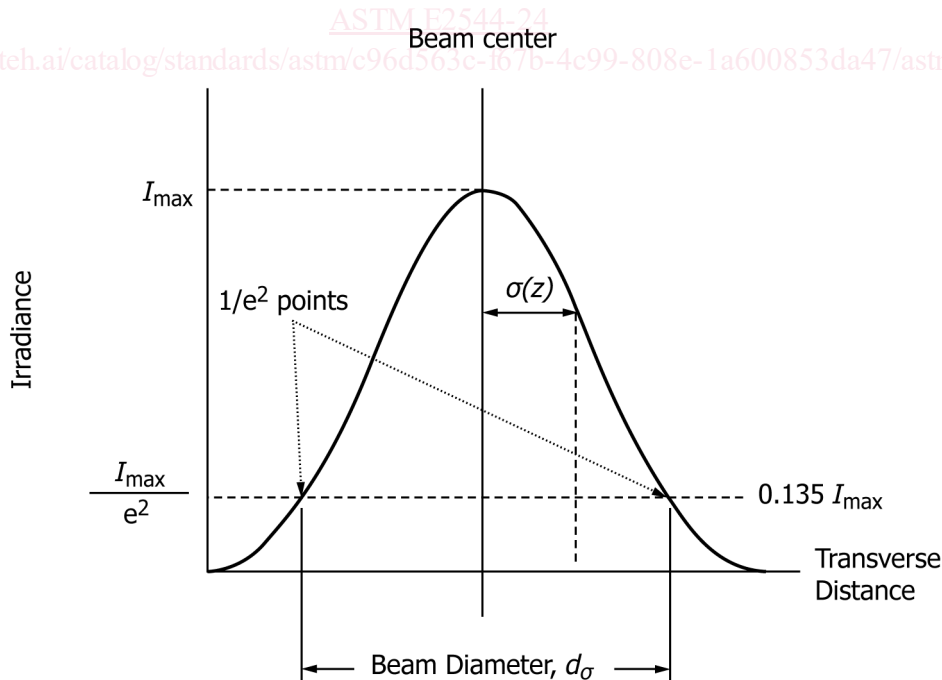

FIG. 1 Gaussian Laser Beam with a Circular Cross Section

(4) The term spot size has been used to mean the radius or the diameter of the laser beam. To avoid confusion, we recommend that spot size not be used.

beam divergence angles (θ_{σ_x} , θ_{σ_y}), n —measure for the asymptotic increase of the beam widths, $d_{\sigma_x}(z)$ and $d_{\sigma_y}(z)$, with increasing distance, z , from the beam waist locations, z_{0x} and z_{0y} , given by:

$$\theta_{\sigma_x} = \lim_{(z-z_{0x}) \rightarrow \infty} \frac{d_{\sigma_x}(z)}{z - z_{0x}}$$

$$\theta_{\sigma_y} = \lim_{(z-z_{0y}) \rightarrow \infty} \frac{d_{\sigma_y}(z)}{z - z_{0y}}$$

DISCUSSION—

(1) Reference ISO 11146-1.

(2) The beam divergence is expressed as a full angle.

(3) For circular laser beams, the beam divergence angle is given by:

$$\theta_{\sigma} = \lim_{(z-z_0) \rightarrow \infty} \frac{d_{\sigma}(z)}{z - z_0}$$

(4) For a perfect Gaussian laser beam of wavelength λ , the beam divergence angle is given by:

$$\theta_{\sigma} = 4 \frac{\lambda}{\pi d_{\sigma 0}}$$

where:

$d_{\sigma 0} = d_{\sigma}(z_0)$ and is the beam width at the beam waist, z_0 . See Fig. 2.

beam propagation ratios (M_x^2 , M_y^2), n —ratios of the product of the divergence angle, θ , and the beam width, d , at the beam waist location z_0 , for a given laser beam to the same product for a perfect Gaussian beam at the same wavelength, and is given by:

$$M_x^2 = \frac{\theta_{\sigma_x} d_{\sigma_x 0}}{\theta_{G\sigma} d_{G\sigma 0}}$$

$$M_y^2 = \frac{\theta_{\sigma_y} d_{\sigma_y 0}}{\theta_{G\sigma} d_{G\sigma 0}}$$

where:

$d_{\sigma_x 0}$, $d_{\sigma_y 0}$ = beam widths at the beam waist locations, z_{0x} and z_{0y}
 = $d_{\sigma_x}(z_{0x})$ and $d_{\sigma_y}(z_{0y})$, respectively,
 $\theta_{G\sigma 0}$ = beam width of a Gaussian beam at the beam waist location, z_0 ,
 $\theta_{G\sigma}$ = beam divergence angle for a Gaussian beam.

DISCUSSION—

(1) For simple astigmatic beams, the beam propagation ratio may also be given by (ISO 11146-1)

$$M_x^2 = \frac{\pi}{\lambda} \frac{\theta_{\sigma_x} d_{\sigma_x 0}}{4}$$

$$M_y^2 = \frac{\pi}{\lambda} \frac{\theta_{\sigma_y} d_{\sigma_y 0}}{4}$$

(2) For a perfect Gaussian beam, $M^2 = 1$. Most laser beams have a beam propagation ratio $M^2 > 1$, however, some high quality laser beams can have values very close to 1.

(3) The beam propagation ratios are propagation invariants for simple astigmatic beams as long as the optics involved do not change their properties.

beam width (d_{σ_x} , d_{σ_y}), n —the extent of the irradiance distribution in a cross section of a laser beam (in a direction orthogonal to its propagation path) at a distance z and is given by:

$$d_{\sigma_x}(z) = 4 \sigma_x(z)$$

$$d_{\sigma_y}(z) = 4 \sigma_y(z)$$

where σ_x and σ_y are the square roots of the second order moments along the principal axes, x and y , respectively. See Fig. 3.

DISCUSSION—

(1) If the ellipticity, ε (the ratio between the minimum and maximum beam widths) of the laser beam is larger than 0.87, the beam profile may be considered to be of circular symmetry and the beam width at a distance z is defined as (ISO 11146-1):

$$d_{\sigma}(z) = 2\sqrt{2(\sigma_x^2 + \sigma_y^2)}^{\frac{1}{2}}$$

(2) For a simple astigmatic laser beam with wavelength λ , the beam widths may be expressed as:

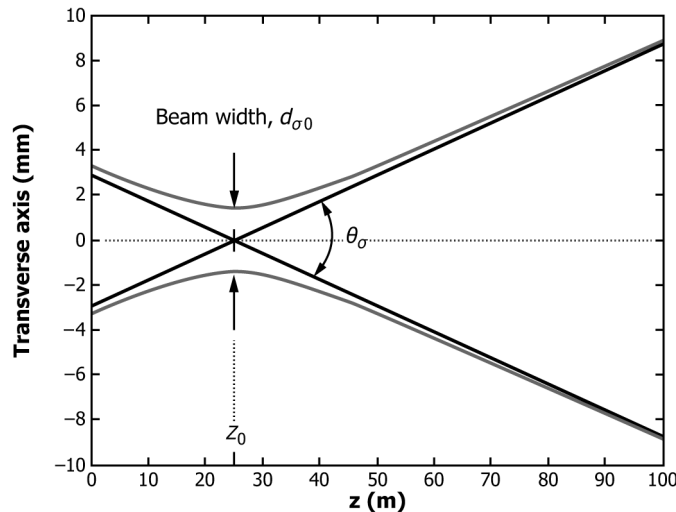

FIG. 2 Perfect Gaussian Beam Profile for a 532 nm beam focused at 25 m

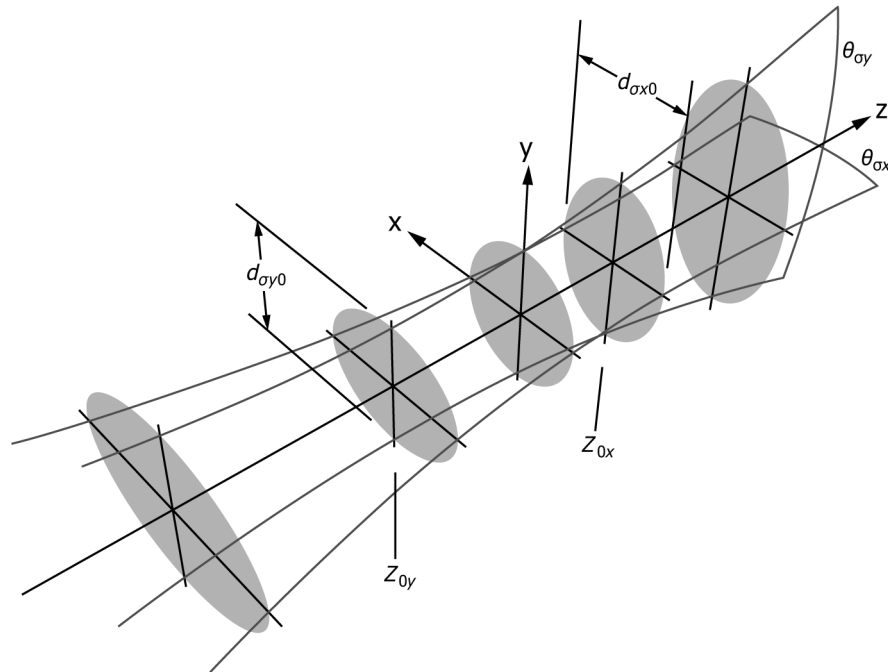

FIG. 3 Schematic Showing Beam Width, Beam Waist, Beam Divergence Angles (Ref ISO 11146)

$$d_{\sigma_x}(z) = d_{\sigma_{x0}} \sqrt{1 + \left(\frac{4M_x^2 \lambda}{\pi d_{\sigma_{x0}}^2} \right)^2 (z - z_{0x})^2}$$

$$d_{\sigma_y}(z) = d_{\sigma_{y0}} \sqrt{1 + \left(\frac{4M_y^2 \lambda}{\pi d_{\sigma_{y0}}^2} \right)^2 (z - z_{0y})^2}$$

where:

M_x^2, M_y^2 = beam propagation ratios,
 $d_{\sigma_{x0}}, d_{\sigma_{y0}}$ = beam widths at the beam waist locations z_{0x} and z_{0y} ,
 = $d_{\sigma_x}(z_{0x})$ and $d_{\sigma_y}(z_{0y})$, respectively.

These equations, $d_{\sigma_x}(z)$ and $d_{\sigma_y}(z)$, are sometimes referred to as the beam propagation equations and are particularly useful for short range, laser-based 3D imaging systems where the laser beam is focused at z_{0x} and z_{0y} . Using these equations, any missing parameter which defines the laser beam can be derived.

(3) For line scanners or sheet of light profilers, the beam width term is equivalent to the line width orthogonal to the longitudinal axis of the line and to the propagation path.

byte, n—grouping of 8 bits, also known as an octet. **E2807**

camel case, n—naming convention in which compound words are joined without spaces with each word’s initial letter capitalized within the component and the first letter is either upper or lowercase. **E2807**

camera image, n—regular, rectangular grid of values that stores data from a 2D imaging system, such as a camera. **E2807**

camera projection model, n—mathematical formula used to convert between 3D coordinates and pixels in a camera image. **E2807**

control network, n—a collection of identifiable points (visible or inferable), with stated coordinate uncertainties, in a single coordinate system.

DISCUSSION—

- (1) An identifiable point is a point that can be uniquely identified throughout the useful life of the control network.
- (2) An example of an inferable point is the center of a sphere, while not visible, can be obtained by processing suitable data.
- (3) The purpose of a control network may include:
 - a. monitoring/controlling data quality (for example, controlling scale error, identifying systematic error),
 - b. registration,
 - c. defining the extent of a measuring environment, and
 - d. verifying the position of an instrument (drift).
- (4) A control network should be established by an accepted best practice.

control point, n—an identifiable point which is a member of a control network.

DISCUSSION—

- (1) An identifiable point is a point that can be uniquely identified throughout the useful life of the control network.
- (2) A control point may be derived from an object that is permanent (for example, benchmark) or temporary (for example, target such as a sphere specifically placed in a scene).

degree of freedom, DOF, n—any of the minimum number of translation or rotation components required to specify completely the pose of a rigid body.

DISCUSSION—

- (1) In a 3D space, a rigid object can have at most 6DOFs, three translation and three rotation.