



Designation: D7158/D7158M – 24a

Standard Test Method for Wind Resistance of Asphalt Shingles (Uplift Force/Uplift Resistance Method)¹

This standard is issued under the fixed designation D7158/D7158M; the number immediately following the designation indicates the year of original adoption or, in the case of revision, the year of last revision. A number in parentheses indicates the year of last reappraisal. A superscript epsilon (ϵ) indicates an editorial change since the last revision or reappraisal.

1. Scope

1.1 This test method covers the procedure for calculating the wind resistance of asphalt shingles when applied in accordance with the manufacturer's instructions and sealed under defined conditions. Shingle designs that depend on interlocking or product rigidity to resist the wind cannot be evaluated using this test method. The method calculates the uplift force exerted on the shingle by the action of wind at specified conditions, and compares that to the mechanical uplift resistance of the shingle. A shingle is determined to be wind resistant at a specified basic wind speed for standard conditions (see 6.3) when the measured uplift resistance exceeds the calculated uplift force for that velocity (3 s gust, ASCE 7).

1.2 The values stated in either SI units or inch-pound units are to be regarded separately as standard. The values stated in each system may not be exact equivalents; therefore, each system shall be used independently of the other. Combining values from the two systems may result in nonconformance with the standard.

1.3 *This standard does not purport to address all of the safety concerns, if any, associated with its use. It is the responsibility of the user of this standard to establish appropriate safety, health, and environmental practices and determine the applicability of regulatory limitations prior to use.*

1.4 *This international standard was developed in accordance with internationally recognized principles on standardization established in the Decision on Principles for the Development of International Standards, Guides and Recommendations issued by the World Trade Organization Technical Barriers to Trade (TBT) Committee.*

¹ This test method is under the jurisdiction of ASTM Committee D08 on Roofing and Waterproofing and is the direct responsibility of Subcommittee D08.02 on Steep Roofing Products and Assemblies.

Current edition approved Feb. 1, 2024. Published February 2024. Originally approved in 2005. Last previous edition approved in 2024 as D7158/D7158M – 24. DOI: 10.1520/D7158_D7158M-24A.

2. Referenced Documents

2.1 ASTM Standards:²

D228/D228M Test Methods for Sampling, Testing, and Analysis of Asphalt Roll Roofing, Cap Sheets, and Shingles Used in Roofing and Waterproofing

D1079 Terminology Relating to Roofing and Waterproofing

D3161/D3161M Test Method for Wind Resistance of Steep Slope Roofing Products (Fan-Induced Method)

D3462/D3462M Specification for Asphalt Shingles Made from Glass Felt and Surfaced with Mineral Granules

D6381/D6381M Test Method for Measurement of Asphalt Shingle Mechanical Uplift Resistance

2.2 ASCE Standards:³

ASCE 7-22 Minimum Design Loads and Associated Criteria for Buildings and Other Structures

ASCE 49-21 Wind Tunnel Testing for Buildings and Other Structures

2.3 ANSI/UL Standard:⁴

ANSI/UL 2390-04 Test Method for Wind Resistant Asphalt Shingles with Sealed Tabs

3. Terminology

3.1 Definitions:

3.1.1 For definition of terms used in this test method, refer to Terminology D1079.

3.2 Definitions of Terms Specific to This Standard:

3.2.1 *seal*—as it relates to steep roofing shingles, is the bonding that results from the activation of the sealant under the action of time and temperature.

3.2.2 *sealant*—as it relates to steep roofing shingles, is defined as factory-applied or field-applied typically asphaltic

² For referenced ASTM standards, visit the ASTM website, www.astm.org, or contact ASTM Customer Service at service@astm.org. For *Annual Book of ASTM Standards* volume information, refer to the standard's Document Summary page on the ASTM website.

³ Available from American Society of Civil Engineers (ASCE), 1801 Alexander Bell Dr., Reston, VA 20191, <http://www.asce.org>.

⁴ Available from American National Standards Institute (ANSI), 25 W. 43rd St., 4th Floor, New York, NY 10036, <http://www.ansi.org>.

material designed to seal the shingles to each other under the action of time and temperature after the shingles are applied to a roof.

3.2.3 *sealed*—the condition of the shingles after they are subjected to the conditioning procedure described in 10.3.

4. Types and Classes of Shingles

4.1 Shingles are classified based on their resistance to wind velocities determined from measured data (Section 11), calculations of uplift force (Section 12), and interpretation of results (Section 13), as follows:

4.1.1 *Class D*—Passed at basic wind speeds up to and including 187 km/h [116 mph].

4.1.2 *Class G*—Passed at basic wind speeds up to and including 249 km/h [155 mph].

4.1.3 *Class H*—Passed at basic wind speeds up to and including 312 km/h [194 mph].

NOTE 1—This standard associates basic wind speeds with the classes shown in this section. Some earlier versions of this standard associated the classes with allowable stress design (ASD) wind speeds. For convenience of any parties interested in correlating this standard with ASD wind speeds, the equivalent ASD wind speeds for Classes D, G, and H are 90 mph, 120 mph, and 150 mph, respectively.

NOTE 2—The symbol for basic wind speed, V , in this standard is equivalent to the use of the symbol, V , in ASCE 7-22 and the 2024 International Building Code (IBC), and to the symbol, V_{ult} in the 2024 International Residential Code (IRC). In prior editions of the IBC and the IRC, the term “ultimate wind speed” or V_{ult} may be used, and it is consistent with the use of “basic wind speed” or V in this standard.

5. Summary of Test Method

5.1 The uplift force induced by wind passing over the surface of asphalt shingles is determined by calculation involving the uplift coefficients obtained from pressures measured above and below the shingle at the windward and leeward sides of the sealant, taking into account the desired basic wind speed classification and the uplift rigidity of the shingle. The calculated uplift force (F_T) for each of the possible classifications is compared to the measured uplift resistance (R_T) of the sealed shingle to establish the wind resistance classification of the shingle.

5.2 The method involves three steps:

5.2.1 Uplift coefficients are determined by measuring pressure differences above and below the shingle as air moves over the surface of a deck of sealed shingles under controlled conditions.

5.2.2 The uplift forces acting on the shingle are calculated using the wind uplift coefficients, shingle sealant configuration, and a specific basic wind speed.

5.2.3 Shingle uplift resistance to that specific basic wind speed is determined by comparing the calculated uplift forces acting on the sealant to the uplift resistances measured with Test Method D6381/D6381M. Uplift resistances from Procedure A and Procedure B are applied against the uplift forces in a manner detailed in the calculation section.

5.3 This test method is applicable to any asphalt shingle surfaced with mineral granules where the shingle above is affixed to the surface of the shingle below with a sealant

(factory or field applied) applied in a pattern aligned parallel to the windward edge of the shingle.

NOTE 3—It is not prohibited to use this test method for research purposes using variations in the number and placement of fasteners. If this is done, the report shall include details of the number and placement of fasteners.

6. Significance and Use

6.1 The wind resistance of sealed asphalt shingles is directly related to the ability of the sealed shingle to resist the force of the wind acting to lift the shingle from the shingle below. This test method employs the measured resistance of the shingle to mechanical uplift after sealing under defined conditions, in a calculation which determines whether this resistance exceeds the calculated force induced by wind passing over the surface of the shingle. Natural wind conditions differ with respect to intensity, duration, and turbulence; while these conditions were considered, and assumptions that specify higher than actual loads are used, extreme natural variations are beyond the means of this test method to simulate.

6.2 Many factors influence the sealing characteristics of shingles in the field; for example, temperature, time, roof slope, contamination by dirt and debris, and fasteners that are misaligned or under driven and interfere with sealing. It is beyond the scope of this test method to address all of these influences. The classification determined in this test method is based on the mechanical uplift resistance determined when representative samples of shingles are sealed under defined conditions before testing.

6.3 The calculations that support the classes in 4.1 apply to buildings of any risk category and any roof slope where all of the following conditions are applicable:

- (1) The ASCE 7-22 mapped basic wind speed (3 s gust) for a given building risk category does not exceed the wind speed associated with the applicable shingle class in Section 4,
- (2) The wind exposure category is B or C,
- (3) The mean roof height does not exceed 60 ft, and
- (4) There are no topographic wind speed-up effects.

NOTE 4—The assumptions used in the calculations for the classes in 4.1 cover the requirements for the majority of the asphalt shingle roofs installed. If environmental factors are outside those listed above as used in the calculations for these classes, other calculations are required to determine the required shingle class based on project-specific conditions; refer to Appendix X1 for additional information and calculation examples. Consult the shingle manufacturer for the specific shingle’s DC_p , EI, L, L_1 , and L_2 values needed to complete these calculations.

NOTE 5—Additional engineering consideration is necessary to verify acceptability of asphalt shingles classified in accordance with this standard for use on Category III and IV buildings for either of the following conditions: (1) geographic areas in which the ASCE 7-22 basic wind speed exceeds 312 km/h [194 mph], or (2) project sites within the “tornado prone region” and determined to require design for tornado loads in accordance with Chapter 32 of ASCE 7-22.

6.4 The test to determine uplift coefficients is conducted with a wind velocity of 15.6 ± 1.3 m/s [35 ± 3 mph]. Research data obtained during the development of this test procedure, as well as standard wind modeling practices, provides for data extrapolation to other wind speeds. In order to simulate the raised shingle edge that is inherent behavior under high wind exposure, shims are inserted under the windward edge of the

shingle as appropriate based on wind speed and uplift rigidity of the shingle being investigated. This test method provides a means of measuring shingle uplift rigidity which is used to determine the correct shim thickness. Additionally, this test method allows for the use of a default value for uplift rigidity (EI) of 7175 N-mm² [2.5 lbf-in.²], if a rigidity measurement is not made. This default value is conservative since the lowest EI measured in the development of this program was 14 350 N-mm² [5.0 lbf-in.²].

NOTE 6—The entire field of wind engineering is based on use of small-scale models in wind tunnels using wind speeds much lower than the full-scale values. Building Codes permit testing of this type to replace the analytical provisions of the Building Code through the provisions of ASCE 7-22. (See [Appendix X1](#) for details and references.)

7. Apparatus

7.1 The apparatus described in Test Method [D6381/D6381M](#), Procedure A, modified as described below, is used to determine the uplift rigidity of the shingle being evaluated.

7.2 The apparatus described in Test Method [D3161/D3161M](#), modified as described below, is used to determine the wind uplift coefficient of the shingle being evaluated.

7.3 Air flow instrumentation capable of continuously measuring and recording time-averaged velocity accurate to ± 0.45 m/s [± 1.0 mph] and a method of traversing the measurement device above the test deck is used to measure velocities of the air flow.

7.4 Air pressure instrumentation capable of continuously measuring and electronically recording the time-averaged pressures of 2.5 to 311 Pa [0.01 to 1.25 in. of water] is used to measure the pressure above and below the shingle on the test deck.

7.5 Shims of thickness 1 ± 0.05 mm [0.04 ± 0.002 in.] and a maximum length and width of 5.1 by 5.1 mm [0.2 by 0.2 in.] are used to lift the windward edge of the shingle during part of the wind uplift coefficient measurements (see [11.2.5](#)). Shims of other thicknesses, but a minimum of 0.1 mm [0.004 in.] and a maximum width and length of 5.1 by 5.1 mm [0.2 by 0.2 in.], are used as required, alone or in combination, to lift the windward edge to the height calculated from the shingle deflection (see [11.2.13](#)).

NOTE 7—The modifications to the Test Method [D3161/D3161M](#) apparatus to induce turbulence, the air flow and pressure measurement instrumentation, and the shims employed, are consistent with the procedure developed for Test Method ANSI/UL 2390 for shingle wind resistance testing.

7.6 The apparatus described in Test Method [D6381/D6381M](#) is used to determine the mechanical uplift resistance of the shingle being evaluated. The selection of Procedure A or B in Test Method [D6381/D6381M](#) is dictated by the magnitude of the forces in front of (F_F) and behind (F_B) the sealant as calculated using the measured wind uplift coefficient and the geometry of the shingle being evaluated (see [12.2](#)).

8. Preparation of Apparatus

8.1 *Shingle Uplift Rigidity*—Use a metal shim 90 by 90 mm [3.5 by 3.5 in.] with thickness equal to or greater than that of the jaw of the pendant clamp in Test Method [D6381/D6381M](#)

to allow insertion of the jaw of the pendant clamp without deflecting the specimen before the test begins. Insert the shim all the way to the base (“stop”) of the specimen clamp on the lower fixture. The second specimen clamp on the lower fixture is not used in this test. The same “stop” shall be used each time for both the shim and the specimens. See [Fig. 1](#).

8.2 Shingle Wind Uplift Coefficient:

8.2.1 Install devices to induce the desired turbulent air flow from the fan-induced wind apparatus used in Test Method [D3161/D3161M](#) as follows:

8.2.1.1 Install a turbulence grid as shown in [Fig. 2](#) in the air flow exit orifice of the fan-induced wind apparatus.

8.2.1.2 Install a bridge panel with roughness strips between the air flow orifice of the apparatus used in Test Method [D3161/D3161M](#) and the test deck as shown in [Fig. 3](#).

8.2.1.3 The overall arrangement of a modified Test Method [D3161/D3161M](#) apparatus is shown schematically in [Fig. 4](#).

8.2.1.4 Test decks shall be constructed in accordance with Test Method [D3161/D3161M](#), with the shingles applied in accordance with the manufacturer’s instructions. The test deck sits on an adjustable stand, and is fixed at 910 mm [36 in.] from the air flow orifice. A rigid bridge with roughness strips (as shown in [Fig. 4](#)) is placed between the orifice and the test deck, and there is no step between the bridge and the deck. The bridge and the deck are both set at a slope of $1.6 \pm 0.5^\circ$. A minimum of 4 ft [1.2 m] of clear space shall be maintained at the sides and back of the test panel deck.

8.2.1.5 The measurement area, as shown in [Fig. 5](#), is an area of 305 by 178 mm [12 by 7 in.] with the long direction perpendicular to the air flow. The area is centered 635 mm [25 in.] from either side of the 1.27 m [50 in.] dimension of the test deck. The front edge of the measurement area shall be the first course of shingles located within the measurement area with its windward edge at least 356 mm [14 in.] from the edge of the test deck closest to the air source.

8.2.1.6 Calibrate the air flow as follows: A vertical velocity profile of time-averaged (mean) velocity shall be measured at the center of the measurement area at 12.7 and 25.4 mm [0.5 and 1.0 in.] above the surface, and at every 25.4 mm [1.0 in.] above the previous measurement to a height of 152 mm [6 in.]. The velocity will increase with distance from the surface, reach a peak value, and begin to decrease with additional height. Record the maximum velocity and its height. This maximum velocity shall be at least 15.6 ± 1.3 m/s [35 ± 3 mph]. A horizontal profile of time-averaged velocities across the measurement area shall be made at the height of maximum velocity (see [Note 8](#)) in the vertical profile, and progressing in 25.4 mm [1.0 in.] steps in both horizontal directions perpendicular to the air flow within the boundaries of the 305 mm [12 in.] wide measurement area. All velocities in the horizontal profile shall be within $\pm 5.0\%$ of the maximum velocity recorded in the vertical profile.

NOTE 8—This height has been demonstrated to occur at approximately 102 mm [4 in.].

8.2.2 Installation of Pressure Taps in the Test Decks:

8.2.2.1 Pairs of pressure taps, used to measure uplift pressure, shall be installed in at least four places on one shingle

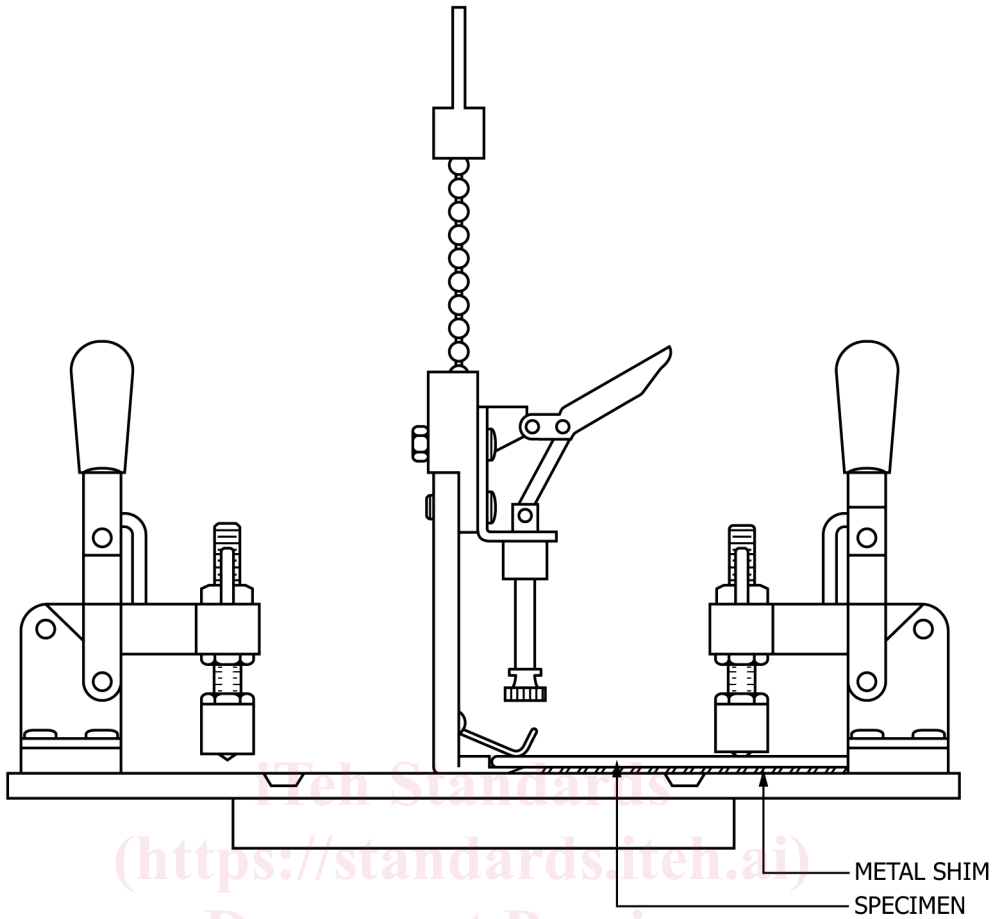
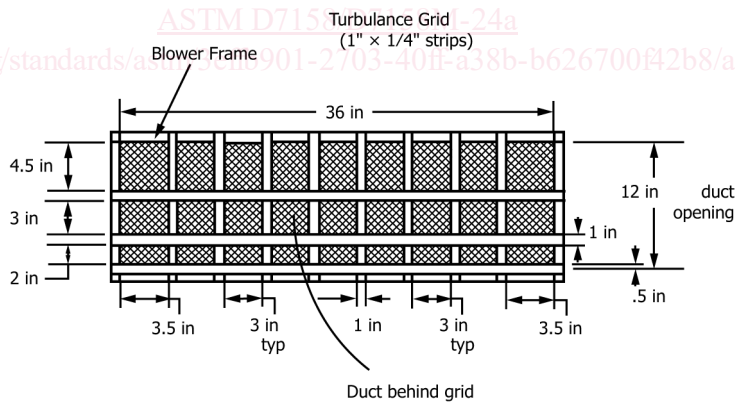

FIG. 1 Apparatus Used in Test Method D6381/D6381M Modified for This Test Method Using a Metal Shim and Using Only One Specimen Clamp



NOTE 1—1 in. = 25.4 mm.

FIG. 2 Turbulence Grid Installed at Air Flow Exit Orifice of Apparatus Used in Test Method D3161/D3161M

(or section of shingle for multi-layered shingles) (see Fig. 6). Four pairs of taps shall be used when the shingle under test has a single sealant stripe pattern, and two additional pairs of taps shall be installed, on a line centered between the most windward and second most windward stripes, to measure uplift pressure for shingles with multiple parallel sealant stripe patterns.

8.2.2.2 The first shingle having its windward edge within the measurement area shall be tapped. The distance L shall be measured and recorded. Two lines of pressure taps shall be placed at $L/2$ and at $L/2 + 76$ mm [$L/2 + 3$ in.] from the windward edge. For standard three-tab shingles, pressure taps shall be placed 51 and 76 mm [2 and 3 in.] on either side of the flow centerline as shown in Fig. 6. In situations where the

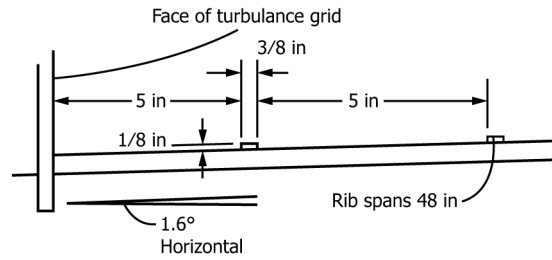

NOTE 1—1 in. = 25.4 mm.

FIG. 3 Bridge Panel with Roughness Strips Installed Between Air Flow Exit Orifice of Apparatus Used in Test Method D3161/D3161M and Test Deck

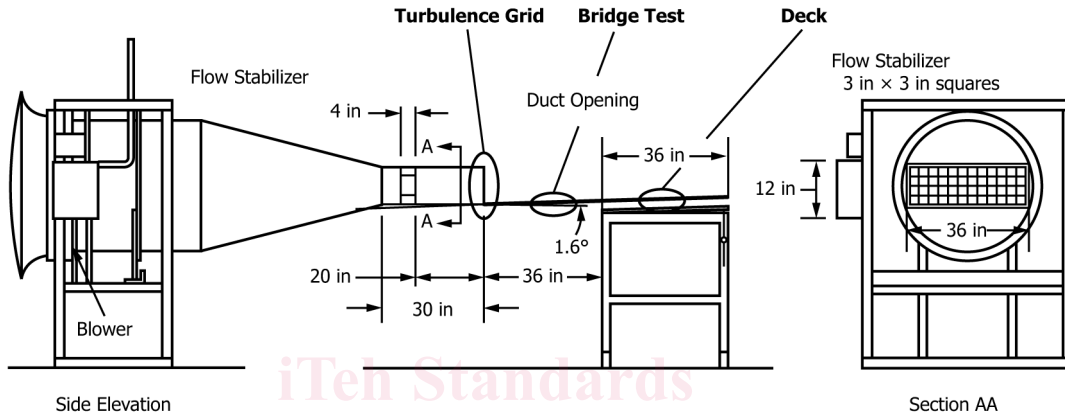

Note: 1 in = 25.4 mm

FIG. 4 Overall Schematic of Test Arrangement for Determination of Wind Uplift Coefficient

specified locations do not provide sufficient space for pressure differentials to be determined, other locations near the windward edge and near the center of the shingle that do provide the pressure differentials shall be selected. Additional taps are not prohibited. For laminated tabs, or other tab or sealant designs, the taps shall be located in the same manner, proportioned to the area being measured.

8.2.2.3 Each pressure tap is a tube with ID of 4.9 to 6.4 mm [0.19 to 0.25 in.]. The bottom pressure tap shall have a tube long enough to project below the sheathing panel for connection to a pressure measurement device. The top pressure tap shall pass through a hole drilled in the shingle, and sheathing below the shingle, and have a light friction fit, as shown in detail B of Fig. 6. The flexible tubing shall be long enough so that it can maintain connection to a pressure measurement device after moving up with the deflected shingle.

8.2.2.4 A pressure measurement device is connected to each of the pressure tubes below the deck sheathing. The pressure measurement device shall be capable of measuring pressures of 2.5 to 311 Pa [0.01 to 1.25 in. of water]. Time-averaged pressure measurements shall be made at each tube. Seal each pressure tap tube during measurements of other taps so that no flow occurs through the taps. (Plug or pinch the flexible connecting tube under the deck.)

8.2.3 Measurements of sealant location and stripe patterns, which influence the position of the pressure taps, are used in the calculation of wind uplift force.

8.2.3.1 The following information shall be measured, or determined from the manufacturer's installation instructions, for the shingle being evaluated (see Fig. 7):

(1) Exposure—The transverse dimension of the shingle (parallel to the roof slope) not overlapped by the shingle directly above it as installed on the roof.

(2) L —The distance measured from the windward edge of the most windward sealant pattern stripe to the windward edge of the affixed shingle as installed on the roof.

(3) L_1 —The distance measured from the centerline of the sealant stripe pattern to the windward edge of the affixed shingle as installed on the roof. For shingle designs with two or more parallel stripes of sealant, the distance is measured from the centerline of the most windward stripe of sealant to the windward edge of the affixed shingle as installed on the roof.

(4) L_2 —The distance measured from the centerline of the sealant stripe pattern of the affixed shingle to the windward edge of the shingle directly above as installed on the roof. For shingle designs with two (or more) parallel stripes of sealant, the distance is measured from the centerline of the second (from the windward) stripe of sealant of the affixed shingle to the windward edge of the shingle directly above as installed on the roof.

(5) L_3 —The distance from centerline to centerline of the two most windward sealant stripes for those shingle designs that include two (or more) parallel stripes of sealant.

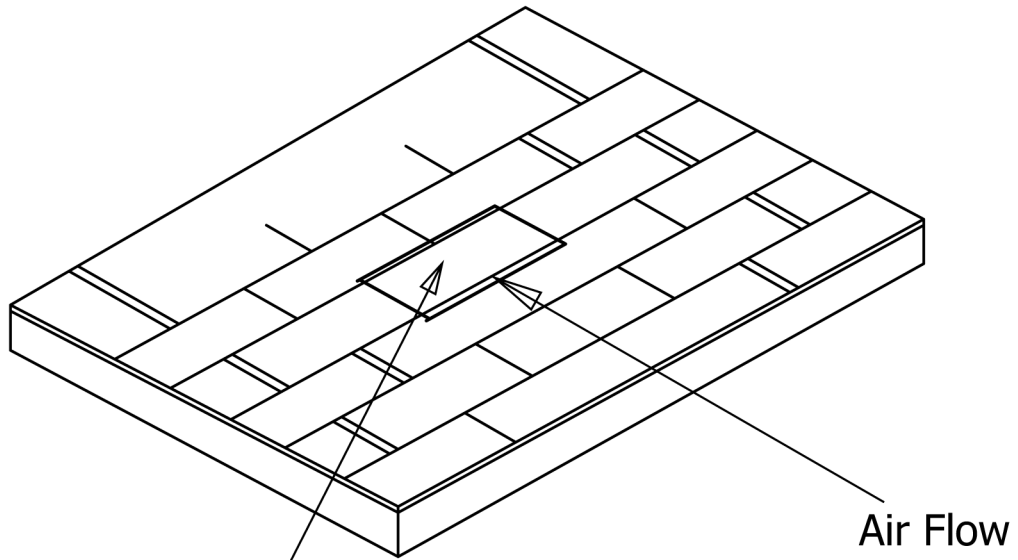

Measurement Area

iTeh Standards
(<https://standards.itih.ai>)
Document Preview

[ASTM D7158/D7158M-24a](https://standards.itih.ai/catalog/standards/astm/3effb961-2703-40ff-a38b-b626700f42b8/astm-d7158-d7158m-24a)

<https://standards.itih.ai/catalog/standards/astm/3effb961-2703-40ff-a38b-b626700f42b8/astm-d7158-d7158m-24a>

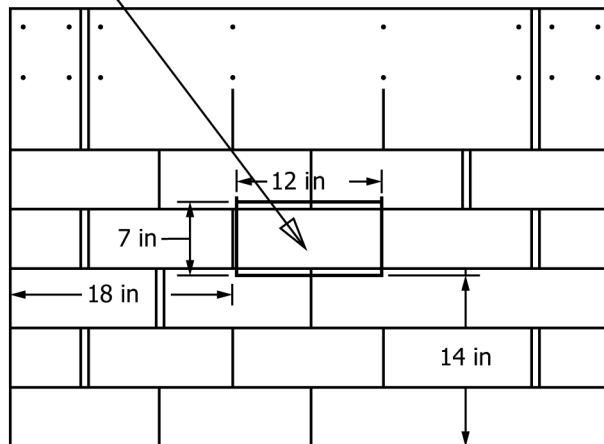

NOTE: 1" = 25.4 mm

FIG. 5 Typical Test Deck Showing Area Where Measurements Are Made Using Pressure Taps