



Designation: ~~F2299/F2299M – 03 (Reapproved 2017)~~ F2299/F2299M – 24

Standard Test Method for Determining the Initial Efficiency of Materials Used in Medical Face Masks to Penetration by Particulates Using Latex Spheres¹

This standard is issued under the fixed designation F2299/F2299M; the number immediately following the designation indicates the year of original adoption or, in the case of revision, the year of last revision. A number in parentheses indicates the year of last reapproval. A superscript epsilon (ϵ) indicates an editorial change since the last revision or reapproval.

1. Scope

1.1 This test method establishes procedures for measuring the initial particle filtration efficiency of materials ~~used in medical facemasks~~ using monodispersed aerosols.

1.1.1 This test method utilizes ~~light scattering~~ light-scattering particle counting in the size range of 0.1 to 5.0 μm and airflow test velocities of 0.5 to 25 cm/s.

1.2 The test procedure measures filtration efficiency by comparing the particle count in the feed stream (upstream) to that in the filtrate (downstream).

1.3 The values stated in SI units or in other units shall be regarded separately as standard. The values stated in each system must be used independently of the other, without combining values in any way.

1.4 The following precautionary caveat pertains only to the test methods portion, Section 10, of this specification. *This standard does not purport to address all of the safety concerns, if any, associated with its use. It is the responsibility of the user of this standard to establish appropriate ~~safety and health~~ safety, health, and environmental practices and determine the applicability of regulatory limitations prior to use.*

1.5 *This international standard was developed in accordance with internationally recognized principles on standardization established in the Decision on Principles for the Development of International Standards, Guides and Recommendations issued by the World Trade Organization Technical Barriers to Trade (TBT) Committee.*

2. Referenced Documents

2.1 ASTM Standards:²

~~D1356 Terminology Relating to Sampling and Analysis of Atmospheres~~

~~D1777 Test Method for Thickness of Textile Materials~~

~~D2905 Practice for Statements on Number of Specimens for Textiles (Withdrawn 2008)~~³

~~D3776/D3776M Test Methods for Mass Per Unit Area (Weight) of Fabric~~

~~E691 Practice for Conducting an Interlaboratory Study to Determine the Precision of a Test Method~~

¹ This test method is under the jurisdiction of ASTM Committee F23 on Personal Protective Clothing and Equipment and is the direct responsibility of Subcommittee F23.40 on Biological.

Current edition approved June 1, 2017/February 2024. Published June 2017/February 2024. Originally approved in 2003. Last previous edition approved in 2017 as F2299/F2299M – 03 (2010); (2017). DOI: 10.1520/F2299_F2299M-03R17-10.1520/F2299_F2299M-24.

² For referenced ASTM standards, visit the ASTM website, www.astm.org, or contact ASTM Customer Service at service@astm.org. For *Annual Book of ASTM Standards* volume information, refer to the standard's Document Summary page on the ASTM website.

³ The last approved version of this historical standard is referenced on www.astm.org.



- F50 Practice for Continuous Sizing and Counting of Airborne Particles in Dust-Controlled Areas and Clean Rooms Using Instruments Capable of Detecting Single Sub-Micrometre and Larger Particles
- F328 Practice for Calibration of an Airborne Particle Counter Using Monodisperse Spherical Particles (Withdrawn 2007)³
- F778 Methods for Gas Flow Resistance Testing of Filtration Media
- F1471 ~~Test Method for Air Cleaning Performance of a High-Efficiency Particulate Air Filter System (Withdrawn 2018)³~~
- F1494 Terminology Relating to Protective Clothing
- F2053 Guide for Documenting the Results of Airborne Particle Penetration Testing of Protective Clothing Materials

3. Terminology

3.1 Definitions:

3.1.1 *aerosol, n*—a suspension of a liquid or solid particles in a gas with the particles being in the colloidal size range.

3.1.1.1 Discussion—

In this test method, aerosols include solid particles having a diameter of 0.1 to 5 μm suspended or dispersed in an airflow at concentrations of less than 102 particles/ cm^3 .

3.1.2 *isokinetic sampling, n*—a condition where the velocity of the airflow entering the sampling nozzle is the same as the velocity of the airflow passing around the sampling nozzle.

3.1.3 *monodispersion, n*—scattering of discrete particles in an airflow where the size is centralized about a specific particle size.

3.1.3.1 Discussion—

In this test method, the monodispersed particle distribution has a mean diameter size of the aerosol in the 0.1 to 5 μm range, with a coefficient of variation of the mean diameter of $\pm 10\%$ or less, as certified by the manufacturer.

3.2 For definitions of other protective clothing-related terms used in this test method, refer to Terminology F1494.

4. Summary of Test Method

4.1 Filtered and dried air is passed through an atomizer to produce an aerosol containing suspended latex spheres.

4.1.1 This aerosol is then passed through a charge neutralizer.

4.1.2 The aerosol is then mixed and diluted with additional preconditioned air to produce a stable, neutralized, and dried aerosol of latex spheres to be used in the efficiency test.

5. Significance and Use

5.1 This test method measures the initial filtration efficiency of materials ~~used in medical face masks~~ by sampling representative volumes of the upstream and downstream latex aerosol concentrations in a controlled airflow chamber.

5.2 This test method provides specific test techniques for both manufacturers and users to evaluate materials when exposed to aerosol particle sizes between 0.1 and 5.0 μm .

5.2.1 This test method establishes a basis of efficiency comparison between ~~medical face mask~~ materials.

5.2.2 ~~This test method does not establish a comprehensive characterization of the medical face mask material for a specific protective application.~~

5.3 ~~This test method does not assess the overall effectiveness of medical face masks in preventing the inward leakage of harmful particles.~~

5.3.1 ~~The design of the medical face mask and the integrity of the seal of the medical face mask to the wearer's face are not evaluated in this test.~~

5.4 ~~This test method is not suitable for evaluating materials used in protective clothing for determining their effectiveness against particulate hazards.~~

5.4.1 In general, clothing design is a significant factor which must be considered in addition to the penetration of particulates.

6. Apparatus

6.1 The aerosol test system incorporates the components as shown in Fig. 1. A more detailed diagram of test system components

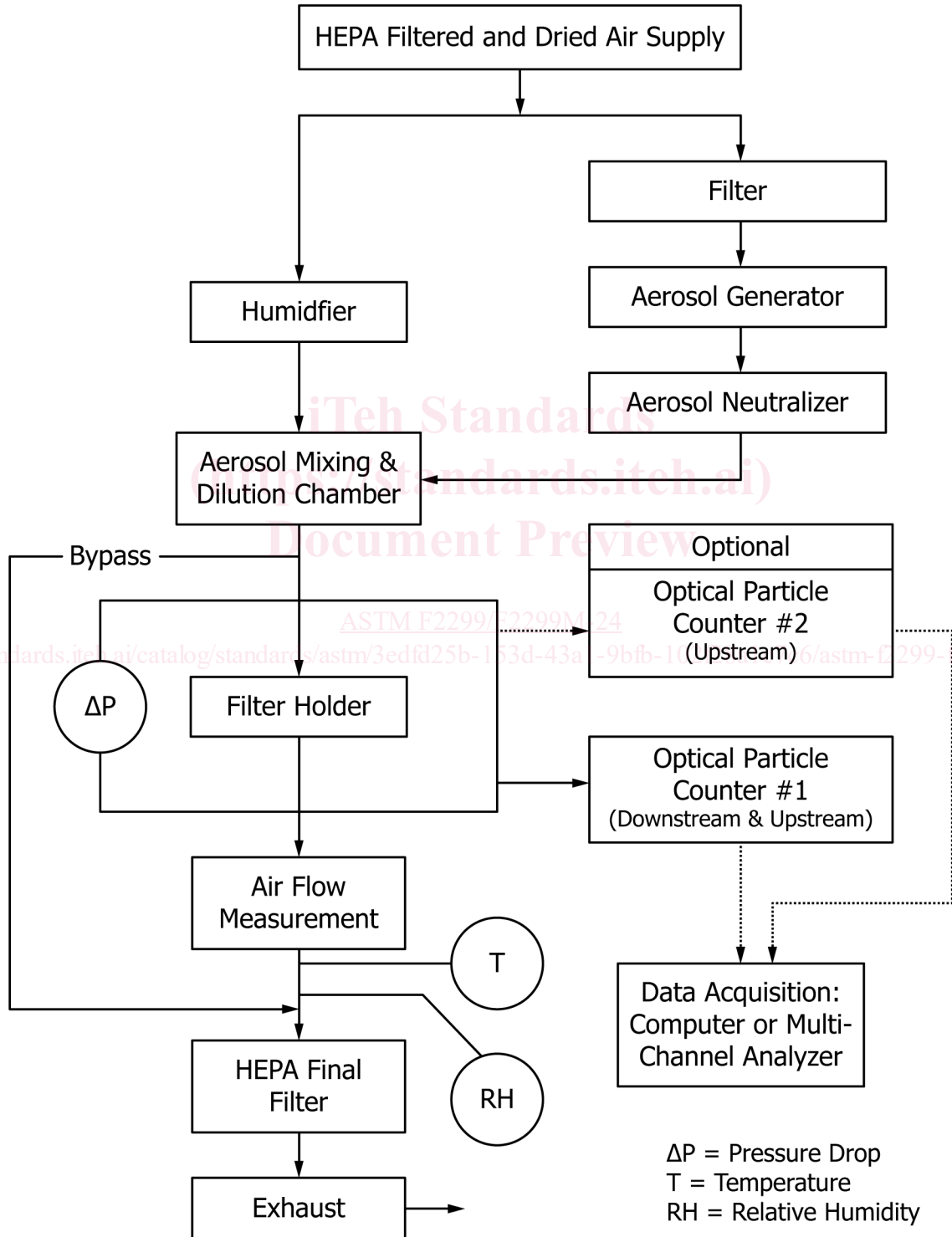

FIG. 1 Schematic of Test Method



and equipment is found in STP 975.⁴

6.2 Equipment:

6.2.1 Clean, dry compressed air supply,

6.2.2 HEPA filters (2),

6.2.3 Aerosol generator,

6.2.4 Charge neutralizer,

6.2.5 Humidifier,

6.2.6 Test filter holder and duct assembly,

6.2.7 Pressure drop measuring device,

6.2.8 ~~Air flow~~ Airflow rate measuring device,

6.2.9 Temperature and relative humidity detectors,

6.2.10 Air blower (optional for negative pressure system), and

6.2.11 Optical particle counters.

7. System Preparation and Control

7.1 To test in the aerosol particle size range of 0.1 to 5.0 μm , it is necessary to maintain a very clean inlet air supply. Achieve acceptable levels of background aerosol by passing the atomizing air supply sequentially through a silica gel dryer (for reduction of moisture), a molecular sieve material (for removal of oil vapor), and an ultra-low penetrating aerosol (better than 99.9999 % efficient at 0.6 μm) filter. Then, supply the air to the test chamber of aerosol generator through pressure regulators of ± 7 kPa [± 1 psi] accuracy. For throttling of the main airflow as well as other flow splitting requirements, use needle valves to maintain adequate flow stability and back pressure. For recommended flow control measurement, see 7.6. Monitor and record the temperature and relative humidity at the exhaust port of the test chamber. To avoid interference from the test aerosol, take the humidity measurement from the outlet side of the HEPA filter (see 7.6.2) with an in-line probe.

7.1.1 To provide a stable, reproducible aerosol through the test material that remains constant over the sampling time of the efficiency test, maintain the main test duct and filter medium specimen holder in a vertical orientation to minimize aerosol sedimentation losses.

7.2 Aerosol Generation:

7.2.1 The aerosol generator must be capable of a latex sphere count ~~concentrations~~ concentration output of 10^7 to 10^8 particles/ m^3 . The suspension reservoir must be large enough to sustain a stabilized output greater than 1 h. Two commercially available atomizing techniques that provide these concentrations of the latex spheres are presented in Figs. 2 and 3.

7.2.2 As viewed in Figs. 2 and 3, these techniques utilize the atomizing of suspended uniform latex spheres from dilute water suspensions. One-liter quantities of these suspensions can be made by diluting the 10 %-by-volume solids of the uniform latex spheres at 1000:1 or greater dilution ratios in deionized, filtered distilled water.

NOTE 1—The suspensions have a three- to six-month usable life. Ideal suspension dilutions are a function of the latex particle size to the aerosol generator droplet size. In order to minimize the atomization of doublets or higher aerosol multiples in the drying process, a recommended latex suspension dilution ratio has been established so that dilution ratios are on the order of 1000:1 to 10 000:1.⁵ Other aerosols produced from these atomizers can be classified

⁴ *Symposium on Gas and Liquid Filtration, Vol II*, ASTM STP 975, ASTM, Vol II, ASTM International, 1986, pp. 141–164.

⁵ Raabe, O., “The Dilution of Monodispersed Suspensions for Aerosolization,” *American Industrial Hygiene Association Journal*, Vol 29, 1968, pp. 439–443.

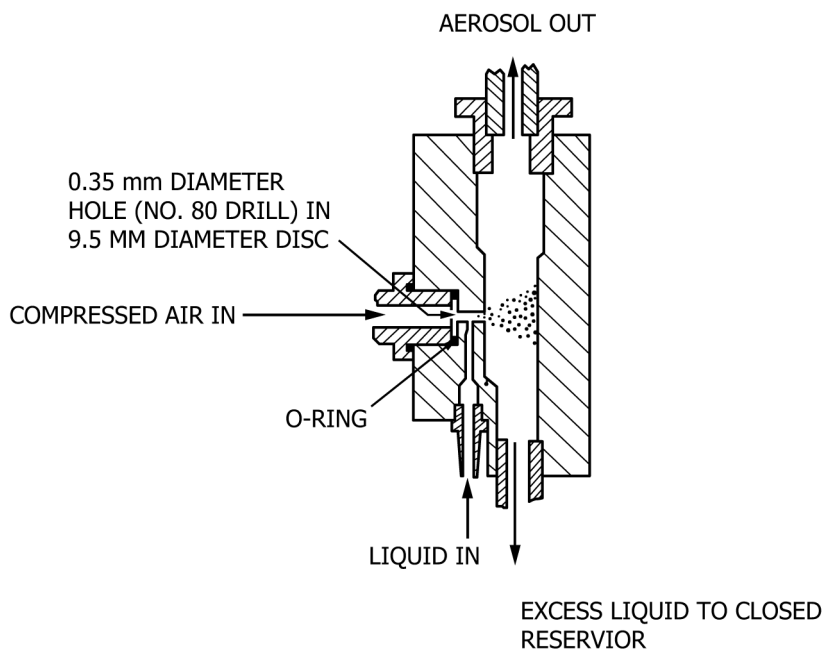

FIG. 2 Atomizer

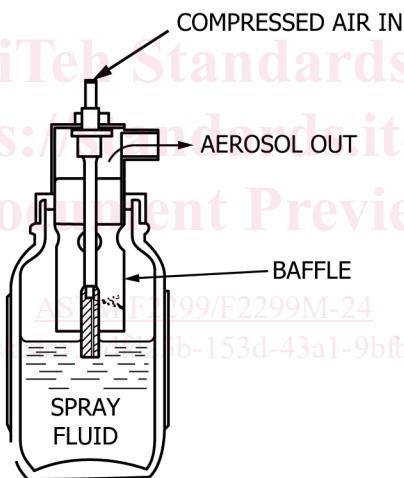

FIG. 3 Collision Atomizer

into monodispersed systems, but for an industrially recognized standard of particle size and composition, the uniform latex spheres are the most reproducible and readily available particles.

7.3 Aerosol Neutralizer—This procedure recommends the use of an aerosol charge neutralizer at the inlet of the test system. This technique generally will ensure aerosol surface charge stability. The aerosol neutralizer can be in the form of a radioactive decay ionizer. The desired Boltzmann's charge equilibrium for the aerosol has been described.⁶ Typically, an ionizing flux of 10^3 mCi/m³/s provides the required aerosol neutralization.

NOTE 2—A Krypton 85 source, a Polonium 210 source, or a Corona electrical discharge, discharge A-C source have been found satisfactory for this purpose.

7.4 Aerosol Dilution and Humidity Control—Prior to injection or dispersion of the initial aerosol concentration into the main test chamber, dry or dilute the aerosol with make-up airflow for the final test aerosol concentration as needed. Conduct material testing in a relative humidity range of 30 to 50 % and hold the relative humidity ± 5 % during a given test. Complete the aerosol mixing a minimum of 8 duct diameters distance before the inlet sampling probe and the material specimen.

⁶ Liu, B. Y. H. and Piu, D. Y. H., "Electrical Neutralization of Aerosols," *Aerosol Science*, Vol 5, 1974, pp. 465–472.



7.5 Material Specimen Holder:

7.5.1 The material specimen holder and test section shall be a continuous straight-walled vessel, interrupted only by the filter medium sample throughout its length. The material specimen holder must provide an uninterrupted ~~airflow~~, airflow passage without measurable peripheral air leakage. Use a ~~50- to 150-mm [2- to 6-in.]~~ 50 to 150 mm [2 to 6 in.] cross-sectional diameter for the medium sample size. Choose the specimen size to ensure that the test specimen is representative of the overall material and provides enough rigidity to be self-supporting.

NOTE 3—The recommended filter medium cross sections allow face velocities of 0.5 to 25 cm/s [approximately 1 to 50 ft/min] at flow rates of 1 L/min to 1 m³/min [approximately 0.035 to 35 ft³/min] to be developed in testing.

7.5.2 Introduce the latex aerosol a minimum of 10 duct diameters upstream of the material specimen and at a sufficient distance to provide thorough mixing before the upstream sampling probe.

7.6 Airflow Metering:

7.6.1 Use a positive pressure (compressed air) or a negative pressure (exhaust fan or blower) system for the airflow to the main test chamber. For the application of any of these techniques of airflow measurement and calibration, refer to the standards and practices of the American Society of Mechanical Engineers.

7.6.2 Use a high efficiency particulate aerosol (~~HEPA~~)-type (HEPA) type filter (99.97 % efficiency on ~~0.3- μ m~~ 0.3 μ m aerosol) upstream of the ~~system~~system's airflow measurement. Size the HEPA-type filter to provide adequate system collection of the exhausting test aerosol.

iTeh Standards
(<https://standards.iteh.ai>)
Document Preview

[ASTM F2299/F2299M-24](#)

<https://standards.iteh.ai/catalog/standards/astm/3edfd25b-153d-43a1-9bfb-102f28a1c7c6/astm-f2299-f2299m-24>