



Standard Specification for Crosslinked Polyethylene/Aluminum/Crosslinked Polyethylene (PEX-AL-PEX) Pressure Pipe¹

This standard is issued under the fixed designation F1281; the number immediately following the designation indicates the year of original adoption or, in the case of revision, the year of last revision. A number in parentheses indicates the year of last reapproval. A superscript epsilon (ϵ) indicates an editorial change since the last revision or reapproval.

1. Scope*

1.1 This specification covers a coextruded crosslinked polyethylene composite pressure pipe with a welded aluminum tube reinforcement between the inner and outer layers. The inner and outer crosslinked polyethylene layers are bonded to the aluminum tube by a melt adhesive. Included is a system of nomenclature for the crosslinked polyethylene-aluminum-crosslinked polyethylene (PEX-AL-PEX) pipes, the requirements and test methods for materials, the dimensions of the component layers and finished pipe, adhesion tests, and the burst and sustained pressure performance. Also given are the requirements and methods of marking. The pipe covered by this specification is intended for use in potable water distribution systems for residential and commercial applications, water service, building supply lines, underground irrigation systems, and radiant panel heating systems, baseboard, snow- and ice-melt systems, and gases that are compatible with the composite pipe and fittings.

NOTE 1— Piping covered by this specification is not recommended for use in indoor flammable gas applications.

1.2 This specification covers only composite pipes incorporating a welded aluminum tube. Pipes consisting of metallic layers not welded together are outside the scope of this specification.

1.3 Specifications for connectors for use with pipe meeting the requirements of this specification are given in **Annex A1**.

1.4 This specification excludes polyethylene-aluminum-polyethylene pipes (see Specification **F1282**).

1.5 The values stated in SI units are to be regarded as standard. The values given in parentheses after SI units are provided for information only and are not considered standard.

1.6 The following precautionary caveat pertains only to the test methods portion, Section 9, of this specification: *This standard does not purport to address all of the safety concerns,*

if any, associated with its use. It is the responsibility of the user of this standard to establish appropriate safety, health and environmental practices and determine the applicability of regulatory limitations prior to use.

1.7 *This international standard was developed in accordance with internationally recognized principles on standardization established in the Decision on Principles for the Development of International Standards, Guides and Recommendations issued by the World Trade Organization Technical Barriers to Trade (TBT) Committee.*

2. Referenced Documents

2.1 ASTM Standards:²

- D618 Practice for Conditioning Plastics for Testing
- D883 Terminology Relating to Plastics
- D1598 Test Method for Time-to-Failure of Plastic Pipe Under Constant Internal Pressure
- D1599 Test Method for Resistance to Short-Time Hydraulic Pressure of Plastic Pipe, Tubing, and Fittings
- D1600 Terminology for Abbreviated Terms Relating to Plastics (Withdrawn 2024)³
- D1898 Practice for Sampling of Plastics (Withdrawn 1998)³
- D2122 Test Method for Determining Dimensions of Thermoplastic Pipe and Fittings
- D2765 Test Methods for Determination of Gel Content and Swell Ratio of Crosslinked Ethylene Plastics
- D3350 Specification for Polyethylene Plastics Pipe and Fittings Materials
- E8/E8M Test Methods for Tension Testing of Metallic Materials
- F412 Terminology Relating to Plastic Piping Systems
- F1282 Specification for Polyethylene/Aluminum/Polyethylene (PE-AL-PE) Composite Pressure Pipe
- F1974 Specification for Metal Insert Fittings for Polyethylene/Aluminum/Polyethylene and Crosslinked Polyethylene/Aluminum/Crosslinked Polyethylene Composite Pressure Pipe

¹ This specification is under the jurisdiction of ASTM Committee F17 on Plastic Piping Systems and is the direct responsibility of Subcommittee F17.11 on Composite.

Current edition approved Feb. 1, 2024. Published February 2024. Originally approved in 1990. Last previous edition approved in 2023 as F1281 – 23a. DOI: 10.1520/F1281-24.

² For referenced ASTM standards, visit the ASTM website, www.astm.org, or contact ASTM Customer Service at service@astm.org. For *Annual Book of ASTM Standards* volume information, refer to the standard's Document Summary page on the ASTM website.

³ The last approved version of this historical standard is referenced on www.astm.org.

*A Summary of Changes section appears at the end of this standard

- 2.2 *National Sanitation Foundation Standard: Standard No. 61 Drinking Water System Components—Health Effects*⁴
*Standard No. 14 Plastics Piping System Components and Related Materials*⁴
- 2.3 *Federal Standard: Fed. Std. No. 123 Marking for Shipments (Civil Agencies)*⁵
- 2.4 *Military Standard: MIL-STD-129 Marking for Shipment and Storage*⁵
- 2.5 *Uniform Classification Committee Standard: Uniform Freight Classification*⁶
- 2.6 *National Motor Freight Traffic Association Standard: National Motor Freight Classification*⁷

3. Terminology

3.1 *Definitions*—Definitions are in accordance with Terminology **F412**, and abbreviations are in accordance with Terminology **D1600**, unless otherwise specified.

3.2 *Definitions of Terms Specific to This Standard:*

3.2.1 *assembly*—the joint between a fitting and a length of pipe.

3.2.2 *PEX-AL-PEX pipe*—composite pipe produced by co-extrusion or extrusion of layers of polyethylene/aluminum/polyethylene bonded together with a melt adhesive and cross-linked by irradiation or chemical means in combination heat and moisture.

3.2.3 *pipe hoop stress*—for simplicity the value of the hoop stress quoted assumes a homogeneous wall. Local values of stress will vary with the different layers (see 3.2.3.1).

3.2.3.1 *Discussion*—Thick walled plastic pipes produced from one material have hoop stresses that vary through the wall, and are usually described by the Lamé Theory. The composite nature of the PEX-AL-PEX pipe, composed of materials with very different Young’s Modulus values, will, on pressurization, not have a uniform stress distribution through

⁴ Available from NSF International, P.O. Box 130140, 789 N. Dixboro Rd., Ann Arbor, MI 48113-0140, <http://www.nsf.org>.

⁵ Available from DLA Document Services, Building 4/D, 700 Robbins Ave., Philadelphia, PA 19111-5094, <http://quicksearch.dla.mil>.

⁶ Available from the Uniform Classification Committee, Suite 1106, 222 South Riverside Plaza, Chicago, IL 60606.

⁷ Available from the National Motor Freight Traffic Association, Inc., National Motor Freight Classification, American Tracking Associations, Inc., Traffic Dept., 1616 P St., NW, Washington, DC 20036.

the thickness of the wall of the pipe. The PEX-AL-PEX pipes have a hoop stress distribution that differs substantially from both the thick and thin walled pipe cases.

4. Pipe Classification

4.1 *Pipe Diameter*—The PEX-AL-PEX pipes are classified by the outside diameter.

4.2 *Pipe Dimension Ratio*—The concept of dimension ratio is not relevant to PEX-AL-PEX composite pipes, and cannot be used to relate pressure rating with total wall thickness.

5. Materials

5.1 *General*—The PEX-AL-PEX pipe is composed of one metallic layer, two layers of polymeric adhesive, and two layers of crosslinked polyethylene. For pipe made to this specification the constituent materials must meet the following requirements:

5.2 *Aluminum*—The aluminum shall have a thickness as specified in **Table 1**. The material shall have minimum elongations and ultimate tensile strengths of 20 % and 100 MPa (14 600 psi), respectively. The tests shall be conducted according to Test Methods **E8/E8M**.

5.3 *Crosslinked Polyethylene:*

5.3.1 The polyethylene shall be, in the final finished state in the pipe, crosslinked as defined in Terminology **D883**.

5.3.2 Polyethylene plastics used to make pipe meeting the requirements of this specification shall be virgin resin meeting the requirements of either Grade PE20A, B, or C; Grade PE23A, B, or C; Grade PE30A, B, or C; or Grade PE33A, B, or C in accordance with Specification **D3350**.

5.3.3 Class B compounds shall have sufficient ultraviolet (UV) stabilizers to protect the pipe from deleterious effects due to continuous outdoor exposure during storage and shipping. Pipe produced from Class B compounds are not suitable for exposed outdoor application. Class A, B, and C compounds shall have sufficient antioxidants to meet the requirements in Specification **D3350**.

5.4 *Melt Adhesive*—The material shall have a density cell of 1, 2, or 3; a melt index cell of 1, 2, or 3; and a color code of A or B, in accordance with Specification **D3350**.

5.5 *Rework Material*—The use of reclaimed, recycled, or rework plastics is not permitted.

TABLE 1 Outside Diameters, Aluminum Thickness, and Tolerances for PEX-AL-PEX

| Diameter Nominal (DN) | Nominal Pipe Size (NPS) | Minimum Outside Diameter, mm (in.) | Tolerance on Minimum, mm (in.) | Maximum Out-of-Roundness, ^A mm (in.) | Minimum Aluminum Thickness, mm (in.) | Tolerance on Thickness, mm (in.) |
|-----------------------|-------------------------|------------------------------------|--------------------------------|---|--------------------------------------|----------------------------------|
| 12 | 3/8 | 12.00 (0.472) | +0.30 (0.012) | 0.3 (0.012) | 0.18 (0.007) | +0.09 (+0.0035) |
| 16 | 1/4 | 16.00 (0.630) | +0.30 (0.012) | 0.4 (0.016) | 0.18 (0.007) | +0.15 (+0.006) |
| 20 | 5/8 | 20.00 (0.787) | +0.30 (0.012) | 0.5 (0.020) | 0.23 (0.009) | +0.23 (+0.009) |
| 25 | 3/4 | 25.00 (0.984) | +0.30 (0.012) | 0.5 (0.020) | 0.23 (0.009) | +0.09 (+0.0035) |
| 26 | 7/8 | 26.00 (1.022) | +0.30 (0.012) | 0.5 (0.020) | 0.53 (0.021) | +0.10 (+0.004) |
| 32 | 1 | 32.00 (1.260) | +0.30 (0.012) | 0.5 (0.020) | 0.28 (0.011) | +0.09 (+0.0035) |
| 40 | 1 1/4 | 39.95 (1.573) | +0.30 (0.012) | 0.5 (0.020) | 0.33 (0.013) | ... |
| 50 | 1 1/2 | 49.90 (1.964) | +0.30 (0.012) | 0.5 (0.020) | 0.47 (0.018) | ... |
| 63 | 2 | 62.90 (2.484) | +0.40 (0.016) | 0.5 (0.020) | 0.57 (0.022) | ... |
| 75 | 2 1/4 | 75.10 (2.957) | +0.60 (0.024) | 1.0 (0.039) | 0.67 (0.026) | ... |

^A The out-of-roundness specification applies only to tubing prior to coiling.

6. Requirements

6.1 *General*—The requirements and test methods in this specification cover PEX-AL-PEX pipes. Tests on the individual layers that comprise this composite pipe are outside the scope of this specification. The raw materials used, however, must conform to the requirements as set out in Section 5.

6.2 Dimensions and Tolerances of Pipe:

6.2.1 *Pipe Diameter*—The minimum outside diameter and tolerances of the pipe shall meet the requirements given in Table 1, when measured in accordance with 9.1 and 9.1.2. Maximum and minimum (out-of-roundness) tolerances apply only to measurements made on pipe prior to coiling.

6.2.2 *Pipe Wall Thickness*—The total pipe wall thickness shall meet the requirements given in Table 2, when measured in accordance with 9.1 and 9.1.3. The minimum wall thickness at any point of measurement of the pipe shall not be less than the value specified in Table 2.

6.2.3 *Inner and Outer Crosslinked Polyethylene Layer Thicknesses*—The thicknesses of the inner and outer layers of crosslinked polyethylene in the PEX-AL-PEX pipe shall have minimum values and tolerance as specified in Table 2, except for the polyethylene material in the outer PEX layer overlaying the weld, which shall have a minimum thickness of half those specified in Table 2. The polyethylene thicknesses shall be measured in accordance with 9.2.

6.2.4 *Pipe Length*—The pipe shall be supplied coiled or in straight lengths as agreed upon with the purchaser and with an allowable tolerance of -0 mm (-0 in.).

6.3 Adhesion Test:

6.3.1 For Sizes 0912 ($3/8$) to 2532 (1) there shall be no delamination of the PEX and AL, either on the bore side or the outside (see Fig. 1). The test shall be conducted in accordance with 9.3.1.

6.3.2 The adhesion test of the PEX-layer to the aluminum for Sizes 3240 ($1\frac{1}{4}$) to 6075 ($2\frac{1}{2}$) is carried out by a separation test. The minimum adhesive force is specified in Table 3. The adhesive force shall not fall below these levels. The test shall be conducted in accordance with 9.3.2.

6.4 *Apparent Tensile Strength of Pipe*—The pipe rings, when tested in accordance with 9.4, shall meet the minimum strength specifications defined in Table 4.

6.5 *Burst Pressure*—The minimum burst pressure for PEX-AL-PEX pipe shall be as given in Table 4, when determined in accordance with 9.5.

6.6 *Sustained Pressure*—The PEX-AL-PEX pipe shall not fail, balloon, burst, or weep, as defined in Test Method D1598, when tested for 10 h at the test at the test pressure given in Table 5 at a temperature of 82 °C (180 °F) in accordance with 9.6.

6.7 *Gel Content*—When tested in accordance with 9.7, the gel content of the inner and outer tubes of crosslinked polyethylene shall have minimum values of either 65 % for the fully crosslinked silane material or 60 % for radiation crosslinked polyethylene. Test Methods D2765 defines gel content (see Note 3).

NOTE 2—The gel test is one of several methods capable of indicating the degree of crosslinking. The different methods for assessing degree of crosslinking do not necessarily agree, so conformity to this specification requires degree of crosslinking to be determined in accordance with 9.7 only.

7. Workmanship

7.1 The pipe shall be free of visible cracks, holes, foreign inclusions, blisters, and other known injurious defects. The pipe shall be as uniform as practicable in color, opacity, density, and other physical properties.

8. Sampling and Conditioning

8.1 *Sampling*—Take a sample of the PEX-AL-PEX pipe sufficient to determine conformance with this specification. The number of specimens designated for each test shall be taken from pipe selected at random in accordance with the random sampling plan of Practice D1898.

NOTE 3—Sample size and testing frequency of lots for quality control must be established by the manufacturer to ensure conformance to the specification. Sampling and frequency will vary with the specific circumstances.

8.2 *Test Specimens*—Not less than 50 % of the test specimens required for any pressure test shall have at least part of the marking in their central sections. The central section is that portion of the pipe that is at least one pipe diameter away from an end closure.

8.3 *Conditioning*—Condition the specimens at 23 °C \pm 2 °C (73.4 °F \pm 3.6 °F) and 50 % \pm 5 % relative humidity for not less than 40 h prior to test in accordance with Procedure A of Practice D618, for those tests where conditioning is required. In cases of disagreement, the tolerances shall be \pm 1 °C (\pm 1.8 °F) and \pm 2 % relative humidity.

TABLE 2 Wall Thickness for PEX-AL-PEX Composite Pipe

| Diameter Nominal (DN) | Nominal Pipe Size (NPS) | Total Wall Thickness, min, mm (in.) | Wall Tolerance (+) mm (in.) | Outer PEX Layer Thickness, min, mm (in.) | Inner PEX Layer Thickness, min, mm (in.) |
|-----------------------|-------------------------|-------------------------------------|-----------------------------|--|--|
| 12 | $3/8$ | 1.60 (0.063) | 0.40 (0.016) | 0.40 (0.016) | 0.70 (0.028) |
| 16 | $1/4$ | 1.65 (0.065) | 0.65 (0.022) | 0.40 (0.016) | 0.90 (0.035) |
| 20 | $5/8$ | 1.90 (0.075) | 0.40 (0.016) | 0.40 (0.016) | 0.96 (0.038) |
| 25 | $3/4$ | 2.25 (0.089) | 0.50 (0.020) | 0.40 (0.016) | 1.10 (0.043) |
| 26 | $7/8$ | 3.00 (0.118) | 0.33 (0.013) | 0.40 (0.016) | 1.32 (0.052) |
| 32 | 1 | 2.90 (0.114) | 0.60 (0.024) | 0.40 (0.016) | 1.34 (0.053) |
| 40 | $1\frac{1}{4}$ | 3.40 (0.134) | 0.60 (0.024) | 0.40 (0.016) | 1.45 (0.057) |
| 50 | $1\frac{1}{2}$ | 4.00 (0.157) | 0.60 (0.024) | 0.40 (0.016) | 1.75 (0.069) |
| 63 | 2 | 4.60 (0.181) | 0.60 (0.024) | 0.40 (0.016) | 1.75 (0.069) |
| 75 | $2\frac{1}{4}$ | 7.25 (0.285) | 0.60 (0.024) | 0.40 (0.016) | 2.80 (0.110) |

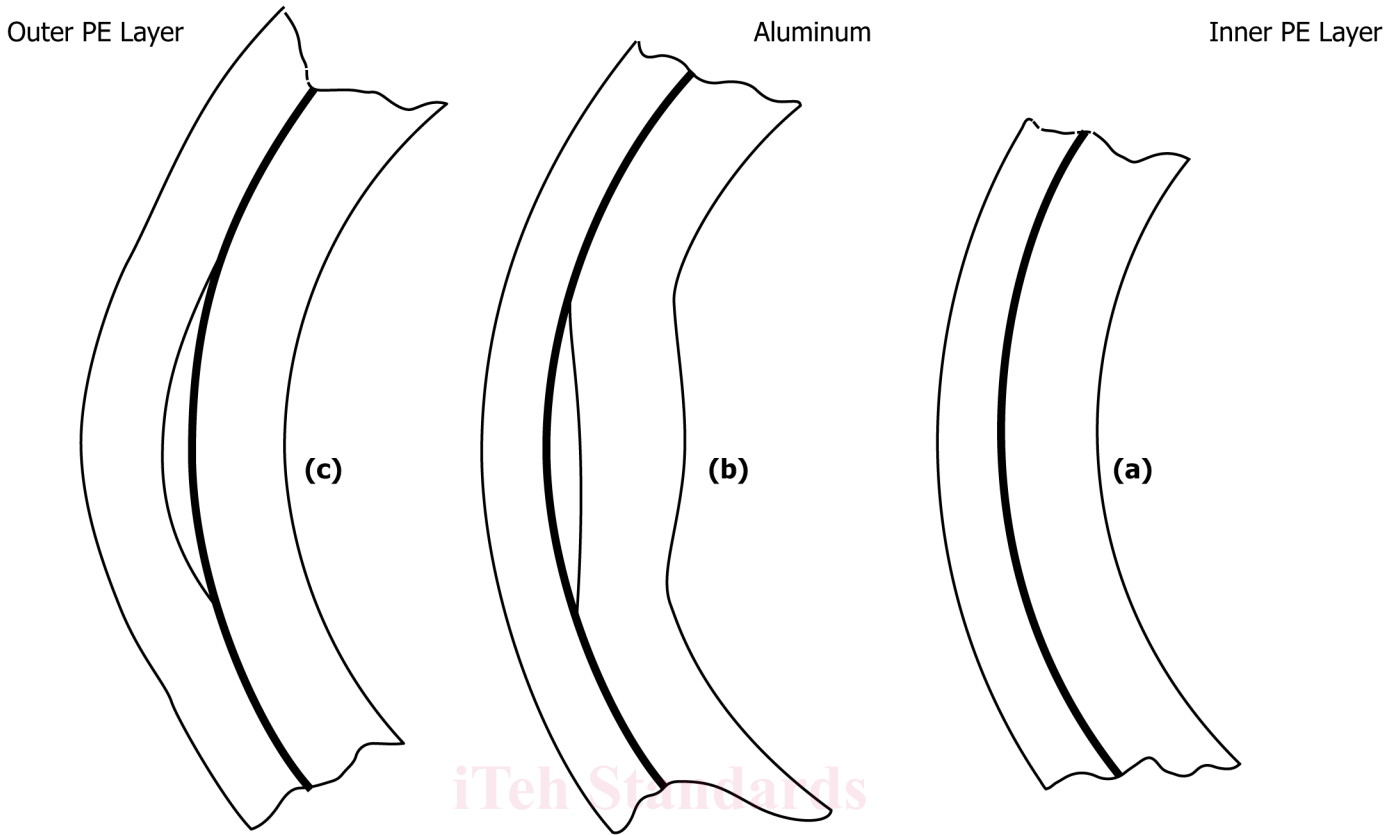

NOTE 1—(a) Good pipe showing no delamination, (b) Delamination between the inner layer and the aluminum, and (c) Delamination between the outer layer and the aluminum.

FIG. 1 Detection of Delamination

TABLE 3 Minimum Adhesive Force for PEX-AI-PEX Composite Pipe

| Diameter Nominal (DN) | Nominal Pipe Size (NPS) | Minimum Adhesive Force per 10 mm (0.394 in.) Pipe Strip, N (lbf) |
|-----------------------|-------------------------|--|
| 40 | 1¼ | 40 (9.0) |
| 50 | 1½ | 50 (11.2) |
| 63 | 2 | 60 (13.5) |
| 75 | 2¼ | 70 (15.7) |

TABLE 5 Minimum Sustained Pressure for PEX-AL-PEX Composite Pipe

| Diameter Nominal (DN) | Nominal Pipe Size (NPS) | Minimum Sustained Pressure PEX-AL-PEX, kPa (psi) |
|-----------------------|-------------------------|--|
| 12 | ¾ | 2720 (395) |
| 16 | ¼ | 2720 (395) |
| 20 | ⅝ | 2720 (395) |
| 25 | ¾ | 2720 (395) |
| 26 | ⅞ | 2720 (395) |
| 32 | 1 | 2720 (395) |
| 40 | 1¼ | 2000 (295) |
| 50 | 1½ | 2000 (295) |
| 63 | 2 | 2000 (295) |
| 75 | 2¼ | 2000 (295) |

TABLE 4 Minimum Pipe Ring Strengths and 23 °C (73.4 °F) Burst Pressure of PEX-AL-PEX Composite Pipe

| Diameter Nominal (DN) | Nominal Pipe Size (NPS) | Minimum Pipe Ring Strength, N(lb) | | Minimum 23 °C (73.4 °F) Burst Pressure, kPa (psi) |
|-----------------------|-------------------------|-----------------------------------|--------------------|---|
| | | Type II PE, N(lb) | Type III PE, N(lb) | |
| 12 | ¾ | 2000 (448) | 2100 (470) | 7000 (1020) |
| 16 | ¼ | 2100 (470) | 2300 (515) | 6000 (880) |
| 20 | ⅝ | 2400 (538) | 2500 (560) | 5000 (730) |
| 25 | ¾ | 2400 (538) | 2500 (560) | 4000 (580) |
| 26 | ⅞ | 2400 (538) | 2500 (560) | 4000 (580) |
| 32 | 1 | 2650 (598) | 2500 (560) | 4000 (580) |
| 40 | 1¼ | 3200 (719) | 3500 (789) | 4000 (580) |
| 50 | 1½ | 3500 (789) | 3700 (832) | 3800 (554) |
| 63 | 2 | 5200 (1169) | 5500 (1236) | 3800 (554) |
| 75 | 2¼ | 6000 (1349) | 6000 (1349) | 3800 (554) |

the test methods or in this specification. In cases of disagreement, the tolerances shall be ±1 °C (1.8 °F) and ±2 % relative humidity.

9. Test Methods

9.1 Dimensions and Tolerances:

9.1.1 Pipe—Any length of the PEX-AL-PEX composite pipe may be used to determine dimensions.

9.1.2 Outside Diameter—Measure the outside diameter of the PEX-AL-PEX pipe in accordance with Test Method D2122.

8.4 Test Conditions—Conduct the test in the standard laboratory atmosphere of 23 °C ± 2 °C (73.4 °F ± 3.6 °F) and 50 % ± 5 % relative humidity, unless otherwise specified in

9.1.3 *Wall Thickness*—Make micrometre measurements of the wall thickness in accordance with Test Method D2122 to determine the maximum and minimum values. Measure the wall thickness at both ends of the pipe to the nearest 0.01 mm (0.0004 in.).

9.2 *Inner and Outer Crosslinked Polyethylene Layer Thicknesses:*

9.2.1 *Sample Preparation*—Cut the pipe with a sharp knife or other suitable cutter, ensuring that the pipe after cutting is not more than 10 % out-of-round.

9.2.2 *Thickness Determination*—Use a hand-held magnifying glass equipped with graduated reticule, or a laboratory microscope with graduated reticule. The reticule should measure to the nearest to 0.1 mm (0.004 in.). Determine the thickness of the inner and outer layers of crosslinked polyethylene (exclusive of the adhesive layer) at six points around the circumference. One of the points only should be at the aluminum weld.

9.3 *Adhesion Tests:*

9.3.1 *Visual Test:*

9.3.1.1 *Cutting the Spiral*—Mount a Stanley 1991 or similarly sharp but rigid razor-like blade within a protective housing and angle to cut a $45 \pm 5^\circ$ spiral in the pipe (see Fig. 2). Choose a PEX-AL-PEX pipe at random and insert into the housing and rotate to form the spiral cut. The cut goes through the complete wall on one side of the pipe only. Run the spiral along the pipe for a minimum distance along the pipe axis equal to five times the outside diameter.

9.3.1.2 *Examining for Delamination*—Firmly hold the pipe with the spiral cut firm at the uncut end and create a ribbon of pipe material by opening out the spiral-cut pipe. Pliers can be used to grip the spiral-cut pipe. Examine the wall of the pipe visually side-on for evidence of delamination between the metal and plastic layers (see Fig. 1).

9.3.2 *Separation Test:*

9.3.2.1 *Specimen*—Five pipe sections of 10 mm (0.394 in.) length are cut at random intervals. The outer layers of the pipe

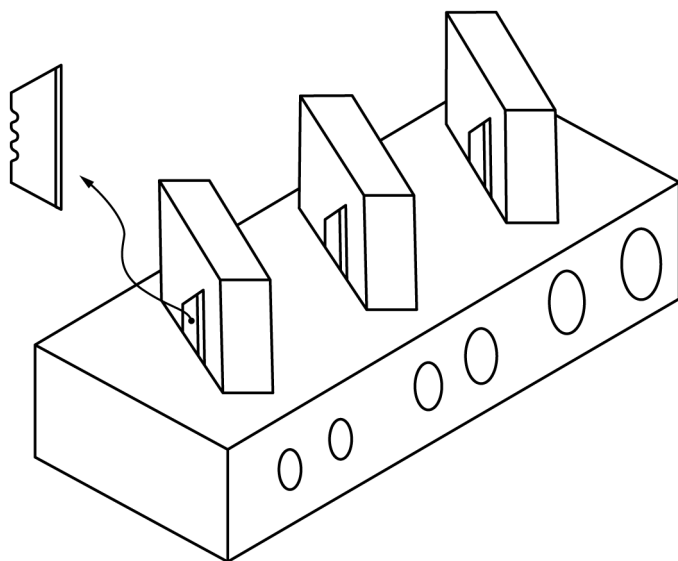

FIG. 2 Spiral Cutter for the Delamination Test

(outer PEX-layer together with the aluminum) are separated mechanically from the inner PEX-layer with an appropriate device on the opposite side to the welding seam. The outer layers are separated on one side to about 5 mm from the pipe in order to allow clamping. The adhesion for the outer PEX-layer to the aluminum is then visually examined for delamination at the corresponding test sample.

9.3.2.2 *Test Equipment:*

(1) *Tension Testing Device*, with suitable pull-off device (see Fig. 3).

(2) D_{roller} = 95 % of the required pipe inner diameter.

(3) d_i = pipe inner diameter.

9.3.2.3 *Test Procedure*—Remove the outer layers from the pipe at $23 \text{ }^\circ\text{C} \pm 2 \text{ }^\circ\text{C}$ ($73.4 \text{ }^\circ\text{F} \pm 3.6 \text{ }^\circ\text{F}$) with a linear speed of 50 mm/min ($\approx 2 \text{ in./min}$). Record the force diagram.

9.4 *Ring Test:*

9.4.1 *Sample Size and Shape*—Cut rings of the PEX-AL-PEX pipe so that the two sides are parallel and at $90 \pm 2^\circ$ to the pipe axis. The width of each ring shall be $25 \text{ mm} \pm 1 \text{ mm}$ ($1 \text{ in.} \pm 0.04 \text{ in.}$). Cut a minimum of 15 samples consecutively along the axis of the pipe.

9.4.2 *Ring Tests*—Test the 15 consecutively cut samples using a tensile testing machine. Arrange the rings so that the aluminum weld is at 90° to the tensile axis as shown in Fig. 4. The crosshead speed shall be $50 \text{ mm/min} \pm 2.5 \text{ mm/min}$ ($2 \text{ in./min} \pm 0.1 \text{ in./min}$). Mount the rings of pipe on two steel rods of minimum diameter of 4 mm (0.16 in.). Record the peak force.

9.5 *Burst Pressure:*

9.5.1 *Pipe Sample*—Select a length of PEX-AL-PEX pipe at random and prepare five consecutive lengths of $300 \text{ mm} \pm 5 \text{ mm}$ ($12 \text{ in.} \pm 0.2 \text{ in.}$). Seal samples at the ends with the appropriate fittings and test either free- or fixed-end.

9.5.2 *Temperature Control*—Test samples at a temperature of $23 \text{ }^\circ\text{C} \pm 2 \text{ }^\circ\text{C}$ ($73.4 \text{ }^\circ\text{F} \pm 3.6 \text{ }^\circ\text{F}$). Contain samples either in a temperature controlled water bath or in air (at standard laboratory atmosphere). For samples contained in a water bath, 1 h conditioning is required. For samples tested in air, a 16 h conditioning period is required.

9.5.3 *Burst Pressure*—Determine the burst pressure in accordance with the procedure in Test Method D1599.

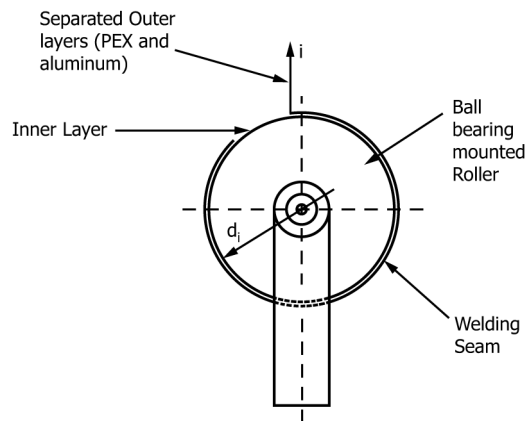

FIG. 3 Setup for Separation Test

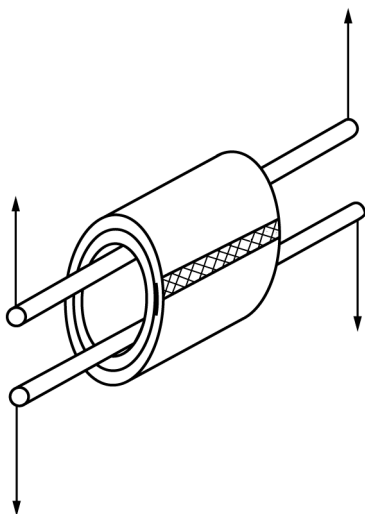

FIG. 4 Schematic Presentation of the Pipe Ring Test Showing the Aluminum Weld at 90° to the Tensile Axis

9.6 Sustained Pressure Test:

9.6.1 Samples—Each test sample of PEX-AL-PEX pipe shall have a minimum length between end closures of at least ten times the average outside diameter, but not less than 250 mm (10 in.). Seal specimens at both ends with the appropriate fittings and fill the samples for testing with water.

9.6.2 Test Procedures—Test the samples in a temperature controlled water bath or in air, in accordance with Test Method D1598. A test temperature of 82 °C ± 2 °C (180 °F ± 3.6 °F) is specified. For each pipe size test six samples. For testing in a water bath, condition the test samples for at least 2 h in the water bath at the test temperature prior to pressurization. For testing in air, condition the samples for at least 4 h in air at the test temperature prior to pressurization. Maintain the pressure at the pressure given in Table 5 for the duration of the test.

9.6.3 Failure—Any continuous loss of pressure of the test sample shall constitute failure of the test. Failure of one of the six is cause for retest of six additional samples under identical conditions. Failure of one of six of the retested samples below the minimum specified lifetime constitutes failure of the test.

9.7 Gel Content Determination:

9.7.1 Sample Preparation—Condition the PEX-AL-PEX pipe in a water bath for a minimum of 24 h at a minimum temperature of 80 °C (176 °F) prior to testing to ensure full crosslinking of the resin. Before taking samples for gel content

evaluation, put pipe in an air-circulating oven at 120 °C (248 °F) for 20 min. Using a lathe, remove 0.1 mm (0.004 in.) thick strands from the outside layer, and 0.2 mm (0.008 in.) thick strands from the inside layer, long enough to obtain a 0.3 g sample for testing. Care should be taken not to cut into the adhesive layer, as it will effect the test results. (See Note 4.)

9.7.2 Test Method—Test the sample from the inner and outer surface separately and in accordance with Sections 12 and 13 of Test Methods D2765, Test Method A.

NOTE 4—Including the adhesive in the test specimen will lower the gel content resulting in a false reading.

10. Quality Assurance

10.1 Quality Assurance—When the product is marked with this designation, ASTM F1281, the manufacturer affirms that the product was manufactured, inspected, sampled, and tested in accordance with this specification and has been found to meet the requirements of this specification. When specified in the purchase order or contract, a report of the test results shall be furnished.

11. Marking

11.1 Quality of Marking—The marking shall be applied to the pipe in such a manner that it remains legible (easily read) after installation.

11.2 Markings on the tubing shall include the following, spaced at intervals of not more than 1.5 m (5 ft):

- 11.2.1 Nominal tubing size (for example, 1216),
- 11.2.2 The material designation “PEX-AL-PEX,”

11.2.3 Pressure rating for water and temperature for which the pressure rating is valid,

11.2.4 ASTM designation F1281, with which the tubing complies, and

11.2.5 Manufacturer’s name (or trademark) and production code.

11.2.6 Tubing intended for the transport of potable water shall also include the seal or mark of the laboratory making the evaluation and the number of the standard used for the evaluation.

NOTE 5—Manufacturers using the seal or mark of a laboratory must obtain prior authorization from the laboratory concerned.

12. Keywords

12.1 composite; crosslinked PE; PEX-AL-PEX; pipe; pressure