



Designation: **D6962—20** **D6962 – 24**

Standard Practice for Operation of a Roller Chair Tester for Pile Yarn Floor Coverings¹

This standard is issued under the fixed designation D6962; the number immediately following the designation indicates the year of original adoption or, in the case of revision, the year of last revision. A number in parentheses indicates the year of last reapproval. A superscript epsilon (ϵ) indicates an editorial change since the last revision or reapproval.

1. Scope

1.1 This practice covers a procedure for the operation of a weighted roller chair testing device that rotates and moves across a test specimen of pile yarn floor coverings.

1.2 This practice is applicable for testing unused pile yarn floor covering of all types.

1.3 The values stated in inch-pound units are to be regarded as standard. The values given in parentheses are mathematical conversions to SI units that are provided for information only and are not considered standard.

1.4 *This standard does not purport to address all of the safety concerns, if any, associated with its use. It is the responsibility of the user of this standard to establish appropriate safety, health, and environmental practices and determine the applicability of regulatory limitations prior to use.*

1.5 *This international standard was developed in accordance with internationally recognized principles on standardization established in the Decision on Principles for the Development of International Standards, Guides and Recommendations issued by the World Trade Organization Technical Barriers to Trade (TBT) Committee.*

2. Referenced Documents

2.1 *ASTM Standards:*²

[D123 Terminology Relating to Textiles](#)

[D1776 Practice for Conditioning and Testing Textiles](#)

[D2240 Test Method for Rubber Property—Durometer Hardness](#)

[D5684 Terminology Relating to Pile Floor Coverings](#)

3. Terminology

3.1 For definitions of terms relating to Pile Floor Coverings, D13.21, refer to Terminology [D5684](#).

3.1.1 The following terms are relevant to this practice: carpet, durability, finished, finished pile yarn floor covering, floor covering, pile, pile yarn floor covering, practice, resistance to delamination, secondary backing, textile floor covering, tufted fabric, underlay.

3.2 For all other terminology related to textiles, refer to Terminology [D123](#).

¹ This practice is under the jurisdiction of ASTM Committee [D13](#) on Textiles and is the direct responsibility of Subcommittee [D13.21](#) on Pile Floor Coverings. Current edition approved ~~Nov. 1, 2020~~ Jan. 1, 2024. Published ~~November 2020~~ February 2024. Originally approved in 2003. Last previous edition approved in 2017 as [D6962–17](#). DOI: [10.1520/D6962-20-20](#). DOI: [10.1520/D6962-24](#).

² For referenced ASTM standards, visit the ASTM website, [www.astm.org](#), or contact ASTM Customer Service at [service@astm.org](#). For *Annual Book of ASTM Standards* volume information, refer to the standard's Document Summary page on the ASTM website.

4. Summary of Test Method

4.1 The carpet test specimen is secured to a table with the pile surface exposed and is subjected to the action of three castors which produce an eccentric turning motion under a weighted roller chair device that moves across the test specimen for a specified number of cycles.

5. Significance and Use

5.1 This practice is applicable for use in testing the durability of pile yarn floor covering of all types.

5.2 This practice is designed to simulate the stress on a pile yarn floor covering from the action of weighted roller chair castors over an extended period of time.

5.3 The specimen is tested under conditions that may simulate an actual flooring installation. This may include the pile yarn floor covering plus a specified underlayment cushion.

5.4 This practice is used to prepare specimens for additional testing, including but not limited to: visual assessment of delamination of the secondary backing, visual assessment of the pile surface, resistance to delamination measurement, tuft bind, and pile yarn raveling.

6. Apparatus and Materials

6.1 *Roller Chair Tester* is constructed of steel with a rotating circular table and a weighted roller fixture, rotating off-center to the table. The apparatus also has electronic controls, a protective cage, and a vacuum system to remove lint and dust. The area of contact between the rollers and the pile yarn wear will be an annulus with an outside diameter of 23.6 ± 0.6 in. (600 ± 15 mm) and inside diameter of 3.9 ± 0.6 in. (100 ± 15 mm).

6.1.1 Rotating circular table is 31.3 in. ± 0.4 in. (795 (795 mm) ± 10 mm) diameter and 0.5 in. ± 0.1 in. (12 (12 mm) ± 1 mm) thick with two stabilizing bolts positioned to prevent the specimen from moving during the test. The base plate rotates at a speed of 2.1 rad/s ± 0.4 rad/s (20 (20 rpm) ± 4 rpm). The disc base plate rotates in one direction for approximately 3 min and then stops for 3 to 5 s before reversing direction.

6.1.2 The roller fixture is offset 7.8 in. ± 0.2 in. (198 (198 mm) ± 4 mm) from the center of the base plate and has three chair castor wheels that are 2.0 in. ± 0.1 in. (50 (50 mm) ± 1 mm) diameter by 0.75 in. ± 0.10 in. (20 (20 mm) ± 1 mm) wide made of polyamide. Hardness is $95 \pm 5^\circ$ Shore A, as measured by Test Method **D2240** for Rubber Property—Durometer Hardness. The three wheels are positioned 5.1 in. ± 0.1 in. (130 (130 mm) ± 2 mm) from the center of the fixture and staggered by 2.1 radians ± 0.1 radians (120°) around the circle. The wheels are offset from the position in the fixture by 1.3 in. ± 0.1 in. (32 (32 mm) ± 2 mm) so as to lag behind during the rotary motion of the fixture.

6.1.3 Motor drive controls the rotation of the circular table and the roller fixture simultaneously at a speed of 6.0 rad/s ± 0.5 rad/s (57 (57 rpm) ± 5 rpm).

6.1.4 Weighted disks provide a force of 66 lb per roller for a total of 198 lb ± 4 lb (90 (90 kg) ± 2 kg). A handwheel on a screw is used to engage weights and raise or lower the roller fixture.

6.1.5 Protective cage covers the rotating table and roller fixture and is in place before operation of the electric motor begins.

6.1.6 Vacuum cleaner with suction hose is attached to a height adjustable head to remove lint and residue during testing. The width of the vacuum head extends across the section traveled by the castor chair wheels. The suction opening is 120 in.² ± 8 in.² (75 – 000 (75 000 mm²) ± 5000 mm²). The suction efficiency is 6060 ft³ ± 6 ft³/min (27 (27 L/s) ± 3 L/s). The vacuum system will operate for 1 min to 1.5 min for every 5 min of operation of the equipment.

6.1.7 The following controls and safety interlocks for the motor are used. Refer to the manufacturer's operation guide regarding other controls and operations:

6.1.7.1 Digital counter with setpoint and reset buttons to measure and control the total number of cycles of rotation.

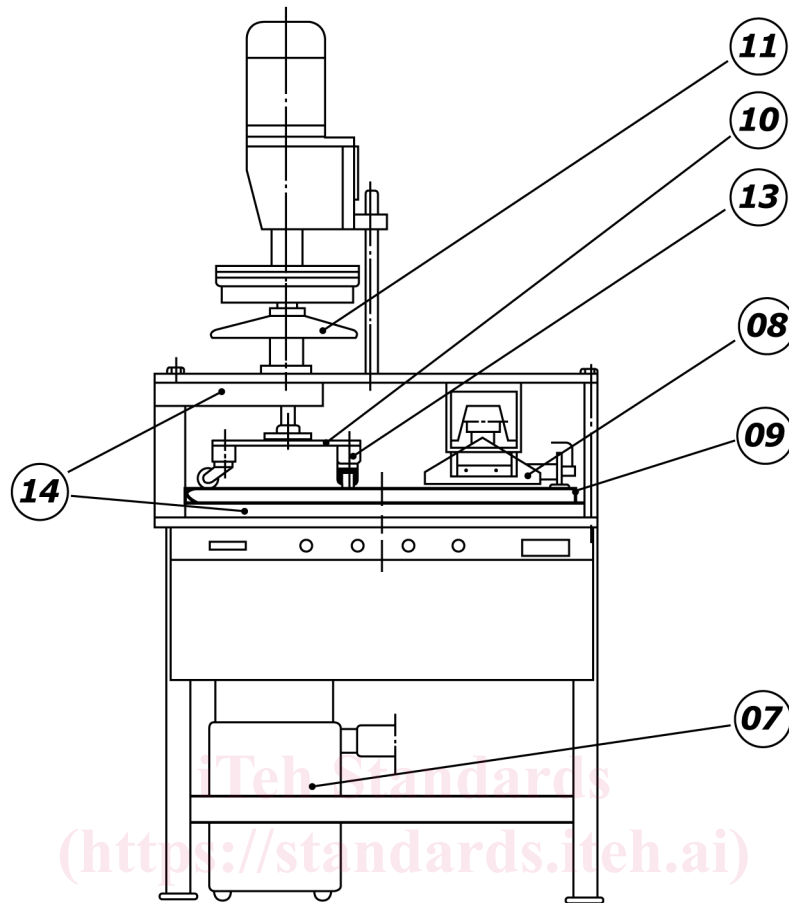

- 07—Vacuum Cleaner
- 08—Suction Nozzle
- 09—Base Table
- 10—Roller Fixture
- 11—Handwheel and weighted disks
- 13—Chair Castors
- 14—Chain guards

FIG. 1 Roller Castor Chair Tester

6.1.7.2 Safety limit switches interlocked to the motor to prevent access to rotating parts during operation.

6.1.7.3 Limit switch in the sample area interlocked to the motor to prevent damage to the equipment in the event the specimen obstructs the rotational path.

6.2 Specimen backing sheet of rigid acrylic or comparable material is 31.25 in. \pm 0.13 in. (790 mm \pm 4 mm) diameter and approximately 0.6 in. (15 mm) thick.

6.2.1 Alternately, use particle board or AC grade plywood with the A-side in contact with the specimen, approximately 0.250.25 in. to 0.625 in. (6 mm to 16 mm) thick, depending upon the thickness of the composite of carpet, underlayment, adhesive, and backing sheet, to permit adequate clearance between the top of the carpet and limit switch.

NOTE 1—A thickness of approximately 0.625 in. (16 mm) is preferred to maintain a rigid and stable substrate.

6.2.2 Either a circular or semicircular specimen template or die is used to cut the carpet specimen. A 31.25 in. \pm 0.13 in. (790 mm \pm 4 mm) diameter acrylic sheet is preferred.

6.3 Underlayment cushion may be used to simulate the specific pile yarn floor covering installation. Choose from one of the many choices of commercially available underlayments.