



Designation: **D4803—18** **D4803 – 24**

An American National Standard

Standard Test Method for Predicting Heat Buildup in PVC Building Products¹

This standard is issued under the fixed designation D4803; the number immediately following the designation indicates the year of original adoption or, in the case of revision, the year of last revision. A number in parentheses indicates the year of last reapproval. A superscript epsilon (ε) indicates an editorial change since the last revision or reapproval.

1. Scope*

1.1 This test method covers prediction of the heat buildup in rigid and flexible PVC building products above ambient air temperature, relative to black, which occurs due to absorption of the sun's energy.

NOTE 1—This test method is expected to be applicable to all types of colored plastics. The responsible subcommittee intends to broaden the scope beyond PVC when data on other materials is submitted for review.

NOTE 2—There are no ISO standards covering the primary subject matter of this test method.

1.2 Rigid PVC exterior profile extrusions for assembled windows and doors are covered in Specification **D4726**.

1.3 Rigid PVC exterior profiles for fencing are covered in Specification **F964**.

1.4 Rigid PVC siding profiles are covered in Specification **D3679**.

1.5 Rigid PVC soffit profiles are covered in Specification **D4477**.

1.6 Rigid PVC and Rigid CPVC plastic building products compounds are covered in Specification **D4216**.

1.7 The text of this test method references notes and footnotes which provide explanatory material. These notes and footnotes (excluding those in tables and figures) shall not be considered as requirements of this test method.

1.8 *Units*—The values stated in inch-pound units are to be regarded as the standard. The values given in parentheses are mathematical conversions to SI units that are provided for information only and are not considered standard.

1.9 *This standard does not purport to address all of the safety concerns, if any, associated with its use. It is the responsibility of the user of this standard to establish appropriate safety, health, and environmental practices and determine the applicability of regulatory limitations prior to use. Specific safety hazard statements are given in Section 7.*

1.10 *This international standard was developed in accordance with internationally recognized principles on standardization established in the Decision on Principles for the Development of International Standards, Guides and Recommendations issued by the World Trade Organization Technical Barriers to Trade (TBT) Committee.*

¹ This test method is under the jurisdiction of ASTM Committee **D20** on Plastics and is the direct responsibility of Subcommittee **D20.24** on Plastic Building Products. Current edition approved Oct. 1, 2018; Feb. 1, 2024. Published October 2018; February 2024. Originally approved in 1989. Last previous edition approved in 2018 as **D4803 – 18**; (2018)¹; DOI: 10.1520/D4803-18; 10.1520/D4803-24.

*A Summary of Changes section appears at the end of this standard

2. Referenced Documents

2.1 ASTM Standards:²

[D883 Terminology Relating to Plastics](#)

[D1600 Terminology for Abbreviated Terms Relating to Plastics](#) (Withdrawn 2024)³

~~[D4703 Practice for Compression Molding Thermoplastic Materials into Test Specimens, Plaques, or Sheets](#)~~

[D3679 Specification for Rigid Poly\(Vinyl Chloride\) \(PVC\) Siding](#)

[D4216 Specification for Rigid Poly\(Vinyl Chloride\) \(PVC\) and Related PVC and Chlorinated Poly\(Vinyl Chloride\) \(CPVC\) Building Products Compounds](#)

[D4477 Specification for Rigid \(Unplasticized\) Poly\(Vinyl Chloride\) \(PVC\) Soffit](#)

~~[D4703 Practice for Compression Molding Thermoplastic Materials into Test Specimens, Plaques, or Sheets](#)~~

[D4726 Specification for Rigid Poly\(Vinyl Chloride\) \(PVC\) Exterior-Profile Extrusions Used for Assembled Windows and Doors](#)

[E456 Terminology Relating to Quality and Statistics](#)

[E631 Terminology of Building Constructions](#)

[F964 Specification for Rigid Poly \(Vinyl Chloride\) \(PVC\) Exterior Profiles Used for Fencing and Railing](#)

3. Terminology

~~3.1 Definitions—Definitions are Terms used in this standard are defined in accordance with Terminologies Terminology [D883](#) or , unless otherwise specified. For terms relating to precision and bias and associated issues, the terms used in this standard are defined in accordance with Terminology [E631](#)~~[E456](#)~~ and abbreviations. Any abbreviations used in this standard are in accordance with Terminology [D1600](#) unless otherwise indicated.~~

3.2 Definitions of Terms Specific to This Standard:

3.2.1 *heat buildup*—the increase in temperature above that of ambient air due to the amount of energy absorbed by a specimen from the sun.

3.2.2 *temperature rise*—the increase in temperature above that of ambient (laboratory) air due to absorption of energy from a heating lamp (source).

4. Summary of Test Method

4.1 The PVC product (extruded product, injection molded part, or compression molded) is cut apart to obtain a flat test specimen at least 3 by 3 by 0.060 ± 0.020 in. (76 by 76 by 1.5 ± 0.5 mm).

4.2 The test specimen is heated under the infrared reflective heat lamp to determine the temperature rise above ambient (laboratory) temperature relative to a black control sample.

4.3 The temperature rise data, obtained in the laboratory for a given test specimen, is then used to predict the heat buildup, which may occur outdoors due to the sun.

5. Significance and Use

5.1 Heat buildup in PVC exterior building products due to absorption of the energy from the sun may lead to distortion problems. Heat buildup is affected by the color, emittance, absorptance, and reflectance of a product. Generally, the darker the color of the product, the more energy is absorbed and the greater is the heat buildup. However, even with the same apparent color, the heat buildup may vary due to the specific pigment system involved. The greatest heat buildup generally occurs in the color black containing carbon black pigment. The black control sample used in this test method contains 2.5 parts of furnace black per 100 parts of PVC suspension resin. The maximum temperature rise above ambient temperature for this black is 90°F (50°C) for a 45° or horizontal surface when the sun is perpendicular to the surface and 74°F (41°C) for a vertical surface assuming that the measurements were done on a cloudless day with no wind and heavy insulation on the back of the specimen.⁴ See ~~Appendix X1~~.

² For referenced ASTM standards, visit the ASTM website, www.astm.org, or contact ASTM Customer Service at service@astm.org. For *Annual Book of ASTM Standards* volume information, refer to the standard's Document Summary page on the ASTM website.

³ The last approved version of this historical standard is referenced on www.astm.org.

⁴ Summers and Brown, *SPE Technical Papers*, XXV, 1979, p. 403.

5.2 This test method allows the measurement of the temperature rise under a specific type heat lamp, relative to that of a black reference surface, thus predicting the heat buildup due to the sun's energy.

5.3 The test method allows prediction of heat buildup of various colors or pigment systems, or both.

5.4 This test method gives a relative heat buildup compared to black under certain defined severe conditions but does not predict actual application temperatures of the product. These will also depend on air temperature, incident angle of the sun, clouds, wind velocity, insulation, installation behind glass, etc.

6. Apparatus

6.1 *Testing Apparatus*—The apparatus shall be constructed essentially as shown in Fig. 1 and shall consist of the following:

6.1.1 *Wooden Box*, ~~opened from~~ open at the top and the front and lined with 1-in. (25.4-mm) thick white rigid hydrous calcium silicate heat insulation.

6.1.2 *White Infrared Heat Lamp*, 250-W.⁵

6.1.3 *Thermocouple*, 40-gage Type J (iron-constantan); Twisted pair typically Type K, J, T, or equivalent.

6.1.4 *Adhesive Tape*, to ensure the thermocouple remains in contact with the back surface of the specimen.

6.1.5 *Digital Read-Out Temperature Meter*, Type J; or equivalent, consistent with the thermocouple type chosen.

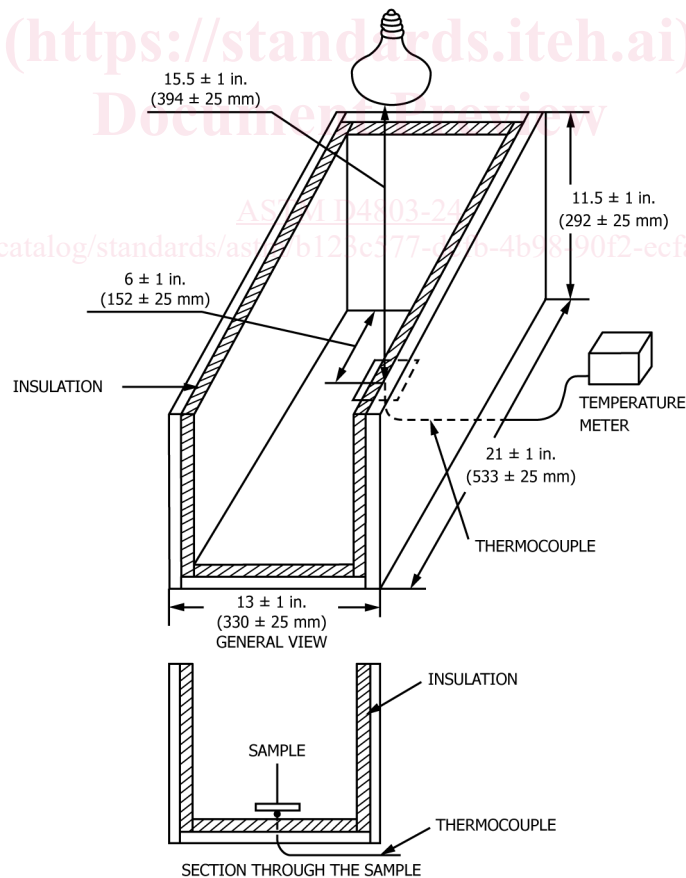

FIG. 1 Apparatus for Measuring Temperature Rise

⁵ A G.E. heat lamp has been found satisfactory for this purpose.