



Standard Specification for Polyethylene of Raised Temperature/Aluminum/Polyethylene of Raised Temperature (PE-RT/AL/PE-RT) Composite Pressure Pipe¹

This standard is issued under the fixed designation F3346; the number immediately following the designation indicates the year of original adoption or, in the case of revision, the year of last revision. A number in parentheses indicates the year of last reapproval. A superscript epsilon (ϵ) indicates an editorial change since the last revision or reapproval.

1. Scope*

1.1 This specification covers a coextruded polyethylene composite pressure pipe with a butt welded aluminum tube reinforcement between the inner and outer layers. The inner and outer polyethylene layers are bonded to the aluminum tube by a melt adhesive. Included is a system of nomenclature for the polyethylene-aluminum-polyethylene of raised temperature (PE-RT/AL/PE-RT) pipes, the requirements and test methods for materials, the dimensions and strengths of the component tubes and finished pipe, adhesion tests, and the burst and sustained pressure performance. Also given are the requirements and methods of marking. The pipe covered by this specification is intended for use in air conditioning and refrigeration (ACR), underground irrigation systems, radiant panel heating systems, baseboard, snow- and ice-melt systems, and gases that are compatible with composite pipe.

1.2 This specification relates only to composite pipes incorporating a butt welded aluminum tube having both internal and external polyethylene layers. The welded aluminum tube is capable of sustaining internal pressures. Pipes consisting of metallic layers not butt welded together and plastic layers other than polyethylene are outside the scope of this specification.

1.3 Specifications for fittings for use with pipe meeting the requirements of this specification are given in [Annex A1](#).

1.4 This specification excludes crosslinked polyethylene-aluminum-crosslinked polyethylene pipes (see Specification [F1281](#)).

1.5 *Units*—The values stated in SI units are to be regarded as standard. The values given in parentheses after SI units are provided for information only and are not considered standard.

1.6 *This standard does not purport to address all of the safety concerns, if any, associated with its use. It is the responsibility of the user of this standard to establish appro-*

priate safety, health, and environmental practices and determine the applicability of regulatory limitations prior to use.

1.7 *This international standard was developed in accordance with internationally recognized principles on standardization established in the Decision on Principles for the Development of International Standards, Guides and Recommendations issued by the World Trade Organization Technical Barriers to Trade (TBT) Committee.*

2. Referenced Documents

2.1 ASTM Standards:²

- [D618 Practice for Conditioning Plastics for Testing](#)
- [D1598 Test Method for Time-to-Failure of Plastic Pipe Under Constant Internal Pressure](#)
- [D1599 Test Method for Resistance to Short-Time Hydraulic Pressure of Plastic Pipe, Tubing, and Fittings](#)
- [D1600 Terminology for Abbreviated Terms Relating to Plastics \(Withdrawn 2024\)³](#)
- [D2122 Test Method for Determining Dimensions of Thermoplastic Pipe and Fittings](#)
- [D2837 Test Method for Obtaining Hydrostatic Design Basis for Thermoplastic Pipe Materials or Pressure Design Basis for Thermoplastic Pipe Products](#)
- [D3350 Specification for Polyethylene Plastics Pipe and Fittings Materials](#)
- [D3895 Test Method for Oxidative-Induction Time of Polyolefins by Differential Scanning Calorimetry](#)
- [E8/E8M Test Methods for Tension Testing of Metallic Materials](#)
- [F412 Terminology Relating to Plastic Piping Systems](#)
- [F1281 Specification for Crosslinked Polyethylene/Aluminum/Crosslinked Polyethylene \(PEX-AL-PEX\) Pressure Pipe](#)

¹ This specification is under the jurisdiction of ASTM Committee [F17](#) on Plastic Piping Systems and is the direct responsibility of Subcommittee [F17.11](#) on Composite.

Current edition approved Feb. 1, 2024. Published February 2024. Originally approved in 2019. Last previous edition approved in 2019 as F3346–19. DOI: 10.1520/F3346–24

² For referenced ASTM standards, visit the ASTM website, www.astm.org, or contact ASTM Customer Service at service@astm.org. For *Annual Book of ASTM Standards* volume information, refer to the standard's Document Summary page on the ASTM website.

³ The last approved version of this historical standard is referenced on www.astm.org.

*A Summary of Changes section appears at the end of this standard

2.2 *ASHRAE Standard*.⁴
ASHRAE Standard 15 Safety Standard for Refrigeration Systems

2.3 *Uniform Classification Committee*.⁵
Uniform Freight Classification

2.4 *National Motor Freight Association Standard*.⁵
National Motor Freight Classification

2.5 *Federal Standard*.⁶
Fed. Std. No. 123 Marking for Shipments (Civil Agencies)

2.6 *Underwriters Laboratory Standards*.⁷
UL 207 Refrigerant-Containing Components and Accessories

UL 1963 Refrigerant Recovery/Recycling Equipment

2.7 *Military Standard*.⁶
MIL-STD-129 Marking for Shipment and Storage

2.8 *PPI Standard*.⁸
PPI TR-3 Policies and Procedures for Developing Hydrostatic Design Basis (HDB), Hydrostatic Design Stresses (HDS), Pressure Design Basis (PDB), Strength Design Basis (SDB), Minimum Required Strength (MRS) Ratings, and Categorized Required Strength (CRS) for Thermoplastic Piping Materials or Pipe

PPI TR-4 PPI Listing of Hydrostatic Design Basis (HDB), Hydrostatic Design Stress (HDS), Strength Design Basis (SDB), Pressure Design Basis (PDB) and Minimum Required Strength (MRS) Ratings For Thermoplastic Piping Materials or Pipe

3. Terminology

3.1 *Definitions*—Definitions are in accordance with Terminology **F412**, and abbreviations are in accordance with Terminology **D1600**, unless otherwise specified.

3.2 *Definitions of Terms Specific to This Standard*:

3.2.1 *assembly, n*—a system made up of pipe, fittings, flanges, valves, or other piping components.

⁴ Available from American Society of Heating, Refrigerating, and Air-Conditioning Engineers, Inc. (ASHRAE), 1791 Tullie Circle, NE, Atlanta, GA 30329, <http://www.ashrae.org>.

⁵ Available from National Motor Freight Traffic Association, Inc. (NMFTA), 1001 N. Fairfax St., Suite 600, Alexandria, VA 22314-1798, <http://www.nmfta.org>.

⁶ Available from DLA Document Services, Building 4/D, 700 Robbins Ave., Philadelphia, PA 19111-5094, <http://quicksearch.dla.mil>.

⁷ Available from Underwriters Laboratories (UL), 2600 N.W. Lake Rd., Camas, WA 98607-8542, <http://www.ul.com>.

⁸ Available from Plastics Pipe Institute (PPI), 105 Decker Court, Suite 825, Irving, TX 75062, <http://www.plasticpipe.org>.

4. Pipe Classification

4.1 *Pipe Diameter*—The PE-RT/AL/PE-RT composite pipes are classified by outside diameter.

NOTE 1—*Pipe Dimension Ratio*—The concept of dimension ratio is not relevant to PE-RT/AL/PE-RT laminated pipes, and cannot be used to relate pressure rating with total wall thickness.

5. Materials

5.1 *General*—The PE-RT/AL/PE-RT pipe is composed of one metallic layer, two layers of the same polyethylene melt adhesive and two layers of the same polyethylene. For pipe made to this specification the constituent materials must meet the following requirements:

5.2 *Aluminum*—The aluminum shall have a thickness as specified in **Table 1**. The material shall have minimum elongations and ultimate tensile strengths of 20 % and 100 MPa (14 600 psi), respectively when tested in accordance with **9.5**.

5.3 *Polyethylene*:

5.3.1 Polyethylene resin used to make pipe meeting the requirements of this specification shall be virgin resin, reworked plastic, or both, and shall have a Plastic Pipe Institute (PPI) HDB established at 23 °C (73 °F) and 82 °C (180 °F).

5.3.1.1 Only polyethylene plastics having an HDB at 82 °C (180 °F) shall be used to manufacture pipe rated at 82 °C (180 °F).

5.3.1.2 The inner PE compound shall meet the color and UV stabilizer code of A, B, C, D or E in accordance with Specification **D3350**. The outer layer PE compound shall meet the color and UV stabilizer code of E in accordance with Specification **D3350**.

5.4 *Polyethylene Melt Adhesive*—The polyethylene melt adhesive shall have a density cell of 1, 2, or 3; a melt index cell of 1, 2, or 3; and a color code of A or B, in accordance with Specification **D3350**.

6. Requirements

6.1 *General*—The requirements and test methods in this specification cover PE-RT/AL/PE-RT pipes. Tests on the individual layers that comprise this composite pipe are outside the scope of this specification. The raw materials used, however, must conform to the requirements in Section **5**.

6.2 *Dimensions and Tolerances of Pipe*:

6.2.1 *Pipe Diameter*—The minimum outside diameter and tolerances of the pipe shall meet the requirements given in **Table 1**, when measured in accordance with **9.1** and **9.1.2**.

TABLE 1 Outside Diameters, Aluminum Thickness, and Tolerances for PE-RT/AL/PE-RT

Diameter Nominal (DN)	Minimum Outside Diameter, mm (in.)	Tolerance on Minimum, mm (in.)	Maximum Out-of-Roundness, ^A mm (in.)	Minimum Aluminum Thickness, mm (in.)	Tolerance on Thickness, mm (in.)
12	12.00 (0.472)	+0.30 (0.012)	0.4 (0.016)	0.16 (0.006)	+0.09 (+0.0035)
14	14.00 (0.552)	+0.30 (0.012)	0.4 (0.016)	0.16 (0.006)	+0.09 (+0.0035)
16	16.00 (0.630)	+0.30 (0.012)	0.5 (0.020)	0.23 (0.009)	+0.09 (+0.0035)
18	18.00 (0.709)	+0.30 (0.012)	0.5 (0.020)	0.23 (0.009)	+0.09 (+0.0035)
20	20.00 (0.787)	+0.30 (0.012)	0.5 (0.020)	0.28 (0.011)	+0.09 (+0.0035)
25	25.00 (0.984)	+0.30 (0.012)	0.5 (0.020)	0.36 (0.014)	+0.09 (+0.0035)
32	32.00 (1.260)	+0.30 (0.012)	0.5 (0.020)	0.46 (0.018)	+0.09 (+0.0035)

^AThe out-of-roundness specification applies only to pipe prior to coiling.

Maximum and minimum (out-of-roundness) tolerances apply only to measurements made on pipe prior to coiling.

6.2.2 *Pipe Wall Thickness*—The total pipe wall thickness shall meet the requirements given in **Table 2**, when measured in accordance with **9.1** and **9.1.3**. The minimum wall thickness at any point of measurement of the pipe shall not be less than the minimum wall thickness specified in **Table 2**.

6.2.3 *Polyethylene Layer Thickness*—The thickness of the inner and outer layers of PE-RT in the PE-RT/AL/PE-RT pipe shall have a minimum value and tolerance as specified in **Table 2**. The PE-RT thickness is measured in accordance with **9.2**.

6.2.4 *Pipe Length*—The pipe shall be supplied coiled or in straight lengths as agreed upon with the purchaser with an allowable tolerance of -0 mm.

6.3 Adhesion Test:

6.3.1 There shall be no delamination of the PE-RT and AL, either on the bore side or the outside (see **Fig. 1**). The test shall be conducted in accordance with **9.3.1**.

6.4 *Apparent Tensile Strength of Pipe*—The pipe rings, when tested in accordance with **9.4**, shall meet the minimum strength as specified in **Table 3**.

6.5 *Minimum Burst Pressure*—The minimum burst pressure for PE-RT/AL/PE-RT pipe shall be as given in **Table 3**, when determined in accordance with **9.6**.

6.6 Sustained Pressure:

6.6.1 The PE-RT/AL/PE-RT pipe rated at $60\text{ }^{\circ}\text{C}$ ($140\text{ }^{\circ}\text{F}$) shall not fail, balloon, burst, or weep, as defined in Test Method **D1598**, when tested for 10 h at the test pressure given in **Table 4** at a temperature of $60\text{ }^{\circ}\text{C}$ ($140\text{ }^{\circ}\text{F}$) in accordance with **9.7**.

6.6.2 PE-RT/AL/PE-RT pipe rated at $82\text{ }^{\circ}\text{C}$ ($180\text{ }^{\circ}\text{F}$) shall not fail, balloon, burst, or weep as defined in Test Method **D1598** when tested in accordance with **9.7** for 10 h at the test pressure given in **Table 4** at a temperature of $82\text{ }^{\circ}\text{C}$ ($180\text{ }^{\circ}\text{F}$).

6.7 *Pressure design basis (PDB)*—All pipe meeting the requirements of this specification shall have a PDB of 400 psi at $23\text{ }^{\circ}\text{C}$ ($73\text{ }^{\circ}\text{F}$) and 200 psi at $82\text{ }^{\circ}\text{C}$ ($180\text{ }^{\circ}\text{F}$) obtained by categorizing the long-term hydrostatic pressure strength determined in accordance with Test Method **D2837** and PPI TR-3. PDB is specific to the particular wall construction and pipe diameter.

6.8 *Refrigerant Exposure*—All pipe designed to be used with refrigerant shall be tested in accordance with **9.8** for compatibility with each refrigerant as specified by the manufacturer

7. Workmanship

7.1 The pipe shall be free of visible cracks, holes, foreign inclusions, blisters, and other known injurious defects. The pipe shall be as uniform as commercially practicable in color, opacity, and regularity of the distribution of the polyethylene inside and outside.

8. Sampling and Conditioning

8.1 *Sampling*—Take a sample of the PE-RT/AL/PE-RT pipe sufficient to determine conformance with this specification. The number of specimens designated for each test shall be taken from pipe selected at random.

NOTE 2—Sample size and testing frequency of lots for quality control must be established by the manufacturer to ensure conformance to the specification. Sampling and frequency will vary with the specific circumstances.

8.2 *Test Specimens*—Not less than 50 % of the test specimens required for any pressure test shall have at least part of the marking in their central sections. The central section is that portion of the pipe that is at least one pipe diameter away from an end closure.

8.3 *Conditioning*—Condition the specimens at $23\text{ }^{\circ}\text{C} \pm 2\text{ }^{\circ}\text{C}$ ($73\text{ }^{\circ}\text{F} \pm 3\text{ }^{\circ}\text{F}$) and $50\% \pm 10\%$ relative humidity for not less than 40 h prior to test in accordance with Procedure A of Practice **D618**, for those tests where conditioning is required. In cases of disagreement, the tolerances shall be $\pm 1\text{ }^{\circ}\text{C}$ ($\pm 2\text{ }^{\circ}\text{F}$) and $\pm 2\%$ relative humidity.

8.4 *Test Conditions*—Conduct the test in the standard laboratory atmosphere of $23\text{ }^{\circ}\text{C} \pm 2\text{ }^{\circ}\text{C}$ ($73\text{ }^{\circ}\text{F} \pm 3\text{ }^{\circ}\text{F}$) and $50\% \pm 10\%$ relative humidity, unless otherwise specified in the test methods or in this specification. In cases of disagreement, the tolerances shall be $\pm 1\text{ }^{\circ}\text{C}$ ($2\text{ }^{\circ}\text{F}$) and $\pm 2\%$ relative humidity.

9. Test Methods

9.1 Dimensions and Tolerances:

9.1.1 *Pipe*—Any length of the PE-RT/AL/PE-RT composite pipe may be used to determine dimensions.

9.1.2 *Outside Diameter*—Measure the outside diameter of the PE-RT/AL/PE-RT pipe in accordance with Test Method **D2122**.

9.1.3 *Wall Thickness*—Make micrometer measurements of the wall thickness in accordance with Test Method **D2122** to determine the maximum and minimum values. Measure the wall thickness at both ends of the pipe to the nearest 0.01 mm (0.0004 in.).

TABLE 2 Wall Thickness for PE-RT/AL/PE-RT Composite Pipe

Diameter Nominal (DN)	Total Wall Thickness, min, mm (in.)	Wall Tolerance (+) mm	Outer PE-RT Layer Thickness, min, mm (in.)	Inner PE-RT Layer Thickness, min, mm (in.)
12	2.45 (0.965)	0.40 (0.016)	0.40 (0.016)	1.00 (0.039)
14	2.50 (0.984)	0.40 (0.016)	0.40 (0.016)	1.20 (0.047)
16	2.45 (0.965)	0.40 (0.016)	0.40 (0.016)	1.20 (0.047)
18	2.75 (0.108)	0.40 (0.016)	0.40 (0.016)	1.30 (0.051)
20	2.70 (0.106)	0.40 (0.016)	0.40 (0.016)	1.40 (0.055)
25	3.25 (0.128)	0.40 (0.016)	0.40 (0.016)	1.40 (0.055)
32	3.75 (0.148)	0.40 (0.016)	0.40 (0.016)	1.40 (0.055)

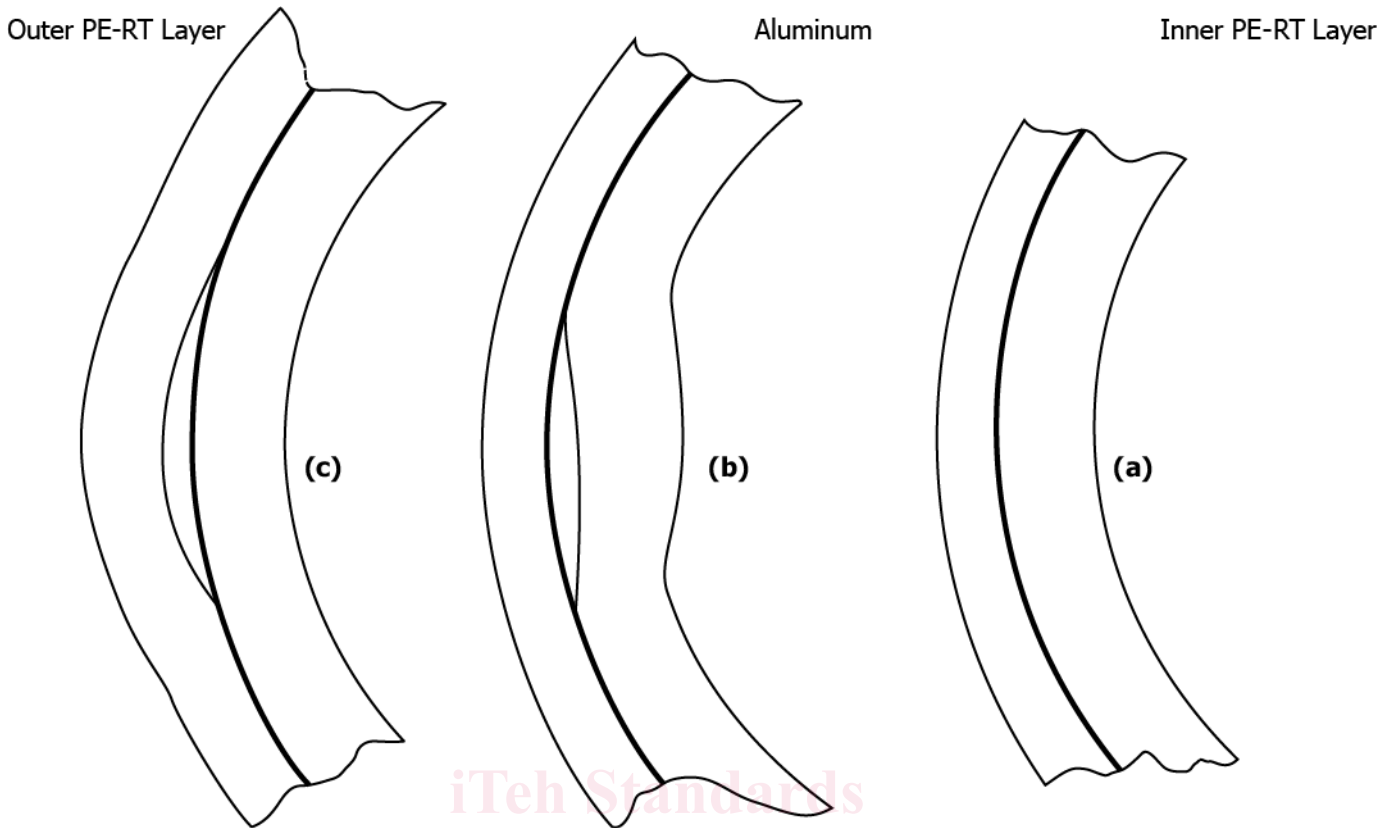

(a) Good pipe showing no delamination, (b) Delamination between the inner layer and the aluminum, and (c) Delamination between the outer layer and the aluminum.

FIG. 1 Detection of Delamination

TABLE 3 Minimum Pipe Ring Strengths and 23 °C (73 °F) Burst Pressure of PE-RT/AL/PE-RT Composite Pipe

Diameter Nominal (DN)	Minimum Pipe Ring Strength N (lb)	Minimum 23 °C (73.4 °F) Burst Pressure, kPa (psi)
12	2100 (470)	6000 (880)
14	2200 (495)	5500 (800)
16	2400 (540)	5000 (730)
18	2400 (540)	5000 (730)
20	2400 (540)	4000 (580)
25	2650 (595)	4000 (580)
32	3200 (720)	4000 (580)

TABLE 4 Minimum Sustained Pressure for PE-RT/AL/PE-RT Composite Pipe

Diameter Nominal (DN)	Minimum Sustained Pressure PE-RT/AL/PE-RT, kPa (psi)	Minimum Sustained Pressure PE-RT/AL/PE-RT, kPa (psi)
	at 60 °C (140 °F)	at 82 °C (180 °F)
12	2480 (360)	2340 (340)
14	2480 (360)	2340 (340)
16	2480 (360)	2340 (340)
18	2480 (360)	2340 (340)
20	2480 (360)	2340 (340)
25	2480 (360)	2340 (340)
32	2100 (305)	1960 (285)

9.2 Polyethylene Layer Thickness:

9.2.1 Sample Preparation—Select the sample of pipe at random. Cut the pipe with a sharp knife or other suitable cutter, ensuring that the pipe after cutting is not more than 10 % out-of-round.

9.2.2 Thickness Determination—Use a hand held magnifying glass equipped with graduated reticule, or a laboratory microscope with graduated reticule. The reticule should measure to the nearest 0.1 mm (0.004 in.). Determine the thickness of the outer coating of polyethylene at six points around the circumference. Only one of the points should be at the aluminum weld.

9.3 Adhesion Test:

9.3.1 Visual Test:

9.3.1.1 Cutting the Spiral—Mount a Stanley 1991 or similarly sharp but rigid razor-like blade within a protective housing and angle to cut a 45 ± 5° spiral in the pipe (Fig. 2). Choose a PE-RT/AL/PE-RT pipe at random and insert into the housing and rotate to form the spiral cut. The cut goes through the complete wall on one side of the pipe only. Run the spiral along the pipe for a minimum distance along the pipe axis equal to five times the outside diameter.

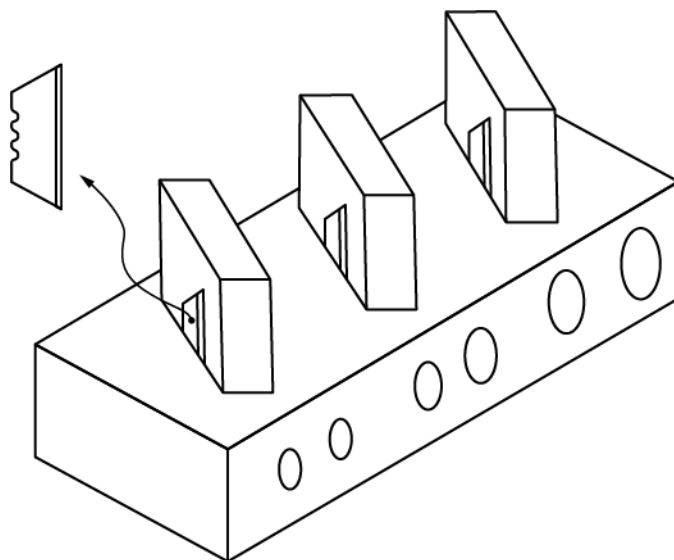

FIG. 2 Spiral Cutter for the Delamination Test

9.3.1.2 *Examining for Delamination*—Firmly hold the pipe with the spiral cut at the uncut end and create a ribbon of pipe material by opening out the spiral-cut pipe. Pliers can be used to grip the spiral-cut pipe. Examine the wall of the pipe visually side-on for evidence of delamination between the metal and plastic layers (see Fig. 1).

9.3.2 *Separation Test:*

9.3.2.1 *Specimen*—Five pipe sections of 10 mm (0.394 in.) length are cut at random intervals. The outer layers of the pipe (outer PE-RT layer together with the aluminum) are separated mechanically from the inner PE-RT layer with an appropriate device on the opposite side to the welding seam. The outer layers are separated on one side to about 5 mm from the pipe in order to allow clamping. The adhesion for the outer PE-RT layer to the aluminum is then visually examined for delamination at the corresponding test sample.

9.3.2.2 *Test Equipment:*

(1) *Tension Testing Device*, with suitable pull-off device (see Fig. 3).

(2) $D_{roller} = 95\%$ of the required pipe inner diameter.

(3) $d_i =$ pipe inner diameter.

9.3.2.3 *Test Procedure*—Remove the outer layers from the pipe at $23\text{ }^{\circ}\text{C} \pm 2\text{ }^{\circ}\text{C}$ ($73\text{ }^{\circ}\text{F} \pm 3\text{ }^{\circ}\text{F}$) with a linear speed of 50 mm/min (≈ 2 in./min). Record the force diagram.

9.4 *Ring Test:*

9.4.1 *Sample Size and Shape*—Cut rings of the PE-RT/AL/PE-RT pipe so that the two sides are parallel and at $90 \pm 2^{\circ}$ to the pipe axis. The length of each ring shall be $25\text{ mm} \pm 1\text{ mm}$ ($1\text{ in.} \pm 0.04\text{ in.}$). Cut a minimum of 15 samples consecutively along the axis of the pipe.

9.4.2 *Ring Tests*—Test the 15 consecutively cut samples using a tensile testing machine. Arrange the rings so that the aluminum weld is at 90° to the tensile axis as shown in Fig. 4. The crosshead speed shall be $50\text{ mm/min} \pm 2.5\text{ mm/min}$ ($2\text{ in./min} \pm 0.1\text{ in./min}$). Mount the rings of pipe on two steel rods of minimum diameter of 4 mm (0.16 in.). Record the peak force.

9.5 *Elongation and Tensile Strength*—Testing of the aluminum for determination of elongation and ultimate tensile strength properties shall be conducted according to Test Methods E8/E8M.

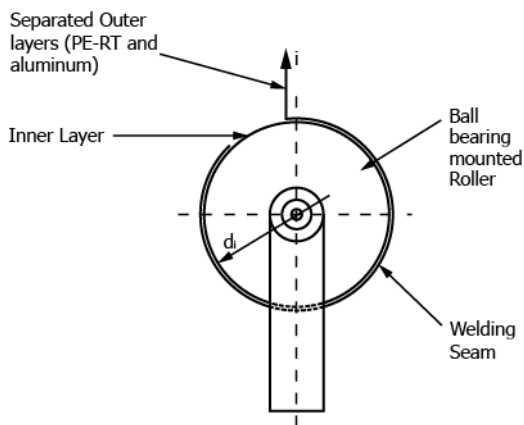

FIG. 3 Setup for Separation Test

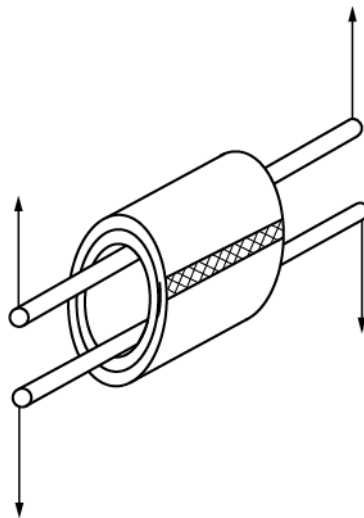

FIG. 4 Schematic Presentation of the Pipe Ring Test Showing the Aluminum Weld at 90° to the Tensile Axis

9.6 *Burst Pressure:*

9.6.1 *Pipe Sample*—Select a length of PE-RT/AL/PE-RT pipe at random and prepare five consecutive lengths of 300 mm ± 5 mm (12 in. ± 0.2 in.). Seal samples at the ends with the appropriate fittings and test either free- or fixed-end.

9.6.2 *Temperature Control*—Test samples at a temperature of 23 °C ± 2 °C (73 °F ± 3 °F). Contain samples either in a temperature-controlled water bath or in air (at standard laboratory atmosphere). For samples contained in a water bath, 1 h conditioning is required. For samples tested in air, a 16 h conditioning period is required.

9.6.3 *Burst Pressure*—Determine the burst pressure in accordance with the procedure in Test Method D1599.

9.7 *Sustained Pressure Test:*

9.7.1 *Samples*—Each test sample of PE-RT/AL/PE-RT pipe shall have a minimum length between end closures of at least ten times the average outside diameter, but not less than 250 mm (10 in.). Seal specimens at both ends with the appropriate fittings and fill the samples for testing with potable drinking water.

9.7.2 *Test Procedures*—Test each sample individually in a temperature controlled water bath or in air in accordance with Test Method D1598. Test at 60 °C ± 2 °C (140 °F ± 3 °F) or 82 °C ± 2 °C (180 °F ± 3 °F) in accordance with 6.6. For each pipe size test six samples. For testing in a water bath, condition the test samples for at least 2 h in the water bath at the test temperature prior to pressurization. For testing in air, condition the samples for at least 4 h in air at the test temperature prior to pressurization. Maintain the pressure at the pressure given in Table 4 for the duration of the test.

9.7.3 *Failure*—Any continuous loss of pressure of the test sample shall constitute failure of the test. Failure of one of the six is cause for retest of six additional samples under identical conditions. Failure of one of six of the retested samples below the minimum specified lifetime constitutes failure of the test.

9.8 *Refrigerant Exposure:*

9.8.1 *Samples*—Each sample shall have a length between end closures of 457 mm (18 in.).

9.8.2 *Test Procedures*—Test three samples of pipe and fitting assemblies for each refrigerant intended to be handled. Inner tube shall be exposed to the liquid phase for 30 days at 80 °C ± 2 °C (176 °F ± 4 °F).

9.8.3 *Failure*—After exposure one sample shall be tested in accordance to 9.9, one sample in accordance to 9.10, and one sample in accordance to 9.11. Any continuous loss of pressure of the test sample shall constitute failure of the test. Failure of one of the three is cause for retest of three additional samples under identical conditions.

9.9 *Vibration Test:*

9.9.1 *Test Procedures*—Pipe and fitting assembly shall be tested in accordance with clause 58.10 of UL 1963.

9.9.2 *Failure*—Any continuous loss of pressure of the test sample shall constitute failure of the test.

9.10 *Pull Test:*

9.10.1 *Test Procedures*—Pipe and fitting assembly shall be tested in accordance with clause 58.11 of UL 1963.

9.10.2 *Failure*—Measured force at assembly failure shall not be less than 163 N (120 lbf).

9.11 *Refrigerant Burst Test*—The pipe and fitting assembly shall be tested to the requirements of either 9.11.1 or 9.11.2.

9.11.1 *Burst Method*—Expose pipe and fitting assembly to a pressure equal to five times the saturated vapor pressure the refrigerant at 66 °C (150 °F), or a pressure equal to five times the design pressure marked on the pipe at 52 °C (125 °F) whichever is higher. Conduct the burst pressure test in accordance with the procedure in Test Method D1599.

9.11.2 *Fatigue Method*—Pipe and fitting assembly shall be tested in accordance with clause 14 of UL 207.

9.11.3 *Failure*—Any continuous loss of pressure of the test sample shall constitute failure of the test.

10. **Quality Assurance**

10.1 When the product is marked with this designation, ASTM F3346, the manufacturer affirms that the product was manufactured, inspected, sampled, and tested in accordance