



Designation: D6111 – 24

Standard Test Method for Bulk Density And Specific Gravity of Plastic Lumber and Shapes by Displacement¹

This standard is issued under the fixed designation D6111; the number immediately following the designation indicates the year of original adoption or, in the case of revision, the year of last revision. A number in parentheses indicates the year of last reapproval. A superscript epsilon (ϵ) indicates an editorial change since the last revision or reapproval.

1. Scope*

1.1 This test method covers the determination of the bulk density and specific gravity of plastic lumber and shapes in their “as manufactured” form. As such, this is a test method for evaluating the properties of plastic lumber or shapes as a product and not a material property test method.

1.2 This test method is suitable for determining the bulk specific gravity or bulk density by immersion of the entire item or a representative cross section in water. This test method involves the weighing of a one piece specimen in water, using a sinker with plastics that are lighter than water. This test method is suitable for products that are wet by, but otherwise not affected by water for the duration of the test.

NOTE 1—This test method was developed for application to plastic lumber materials, but it is generic enough that it would be equally applicable to other plastic composite materials, including wood-plastic composite materials.

1.3 Plastic lumber and plastic shapes are currently made predominately from recycled plastics. However, this test method would also be applicable to similar manufactured plastic products made from virgin resins where the product is non-homogeneous in the cross-section.

1.4 The values stated in SI units are to be regarded as standard.

1.5 *This standard does not purport to address all of the safety concerns, if any, associated with its use. It is the responsibility of the user of this standard to establish appropriate safety, health, and environmental practices and determine the applicability of regulatory limitations prior to use.*

NOTE 2—There is no known ISO equivalent to this test method.

1.6 *This international standard was developed in accordance with internationally recognized principles on standardization established in the Decision on Principles for the Development of International Standards, Guides and Recommendations issued by the World Trade Organization Technical Barriers to Trade (TBT) Committee.*

¹ This test method is under the jurisdiction of ASTM Committee D20 on Plastics and is the direct responsibility of Subcommittee D20.20 on Plastic Lumber (Section D20.20.01).

Current edition approved Feb. 1, 2024. Published February 2024. Originally approved in 1997. Last previous edition approved in 2019 as D6111 – 19a. DOI: 10.1520/D6111-24.

Developed in accordance with the principles of standardization established in the Decision on Principles for the Development of International Standards, Guides and Recommendations issued by the World Trade Organization Technical Barriers to Trade (TBT) Committee.

2. Referenced Documents

2.1 ASTM Standards:²

D618 Practice for Conditioning Plastics for Testing

D883 Terminology Relating to Plastics

D1622/D1622M Test Method for Apparent Density of Rigid Cellular Plastics

D1898 Practice for Sampling of Plastics (Withdrawn 1998)³

D5033 Guide for Development of ASTM Standards Relating to Recycling and Use of Recycled Plastics (Withdrawn 2007)³

D6108 Test Method for Compressive Properties of Plastic Lumber and Shapes

E1 Specification for ASTM Liquid-in-Glass Thermometers

E12 Terminology Relating to Density and Specific Gravity of Solids, Liquids, and Gases (Withdrawn 1996)³

E456 Terminology Relating to Quality and Statistics

E691 Practice for Conducting an Interlaboratory Study to Determine the Precision of a Test Method

E2935 Practice for Evaluating Equivalence of Two Testing Processes

3. Terminology

3.1 Definitions of Terms:

3.1.1 Definitions of terms applying to this test method appear in Terminology D883 and Guide D5033. For terms relating to precision and bias and associated issues, the terms used in this test method are in accordance with the definitions in Terminology E456.

3.1.2 *density, bulk*—the weight per unit volume of a material including voids inherent in material as tested. (Terminology D883)

3.1.3 *plastic lumber, n*—a manufactured product made primarily from plastic materials (filled or unfilled), typically used

² For referenced ASTM standards, visit the ASTM website, www.astm.org, or contact ASTM Customer Service at service@astm.org. For *Annual Book of ASTM Standards* volume information, refer to the standard’s Document Summary page on the ASTM website.

³ The last approved version of this historical standard is referenced on www.astm.org.

*A Summary of Changes section appears at the end of this standard

as a building material for purposes similar to those of traditional lumber, which is usually rectangular in cross-section. (Terminology D883)

3.1.3.1 *Discussion*—Plastic lumber is typically supplied in sizes similar to those of traditional lumber board, timber and dimension lumber; however the tolerances for plastic lumber and for traditional lumber are not necessarily the same. (Terminology D883)

3.1.4 *resin, n*—a solid or pseudosolid organic material often of high molecular weight, which exhibits a tendency to flow when subjected to stress, usually has a softening or melting range, and usually fractures conchoidally. (Terminology D883)

3.1.4.1 *Discussion*—In a broad sense, the term is used to designate any polymer that is a basic material for plastics.

3.2 *Definitions of Terms Specific to This Standard:*

3.2.1 *plastic shape, n*—a manufactured product made primarily from plastic materials (filled or unfilled), which is not necessarily rectangular in cross section.

3.2.2 *specific gravity, bulk (of solids)*—the ratio of the weight in air of a unit volume of a permeable material (including both permeable and impermeable voids normal to the material) at a stated temperature to the weight in air of equal density of an equal volume of gas-free distilled water at a stated temperature.

3.2.2.1 *Discussion*—The accuracy of bulk density determinations is so low that corrections for air buoyancy and variations in the value for the acceleration of gravity are not warranted. Hence, this definition is based on weights in air and not on mass. This definition and discussion are based on the concepts in Terminology E12.

4. Summary of Test Method

4.1 Determine the weight of a specimen of the plastic lumber or shape in air. The specimen is then immersed in water, its weight upon immersion is determined, and its bulk specific gravity calculated.

5. Significance and Use

5.1 The specific gravity or density of a solid is a property that can be measured conveniently to follow physical changes in a sample, to indicate degree of uniformity among different sampling units or specimens, or to indicate the average density of a large item.

5.2 It is possible that variations in density of a particular plastic lumber or shapes specimen will be due to changes in crystallinity, loss of plasticizer/solvent content, differences in degree of foaming, or to other causes. It is possible that portions of a sample will differ in density because of difference in crystallinity, thermal history, porosity, and composition (types or proportions of resin, plasticizer, pigment, or filler).

NOTE 3—Reference is made to Test Method D1622/D1622M.

5.3 Density is useful for calculating strength to weight and cost to weight ratios.

5.4 If the cross-sectional area of the specimen is required for future testing on a particular sample, it is acceptable to determine it from a specific gravity measurement, see Eq 4.

6. Apparatus

6.1 *Balance*—A balance large enough to accommodate the specimen conveniently, with a precision within 1.0 mg, accuracy within 0.05 % relative (that is 0.05 % of the weight of the specimen in air), and equipped with a means of support for the immersion cage.

6.1.1 Calibrate the balance at least annually in accordance with the manufacturer’s instructions for zero point, sensitivity, and absolute accuracy.

6.2 *Immersion Cage:*

6.2.1 *Wire*—A corrosion-resistant wire for suspending the cage.

6.2.2 *Cage*—A device large enough to support the bottom of the specimen and when weighted will transfer the sinker force to the specimen to keep it from floating. Refer to the sample immersion cage diagrammed in Fig. 1.

6.2.3 *Sinker*—A sinker for use with specimens of plastics that have specific gravities less than 1.000. The sinker shall: be corrosion-resistant; have a specific gravity of not less than 7.0; have smooth surfaces and a regular shape; and be slightly heavier than necessary to sink the specimen. It is important that the sinker be easily attached to the cage.

6.3 *Immersion Vessel*—A beaker, bucket, or other wide-mouthed vessel for holding the water and immersed cage.

6.4 *Thermometer*—A thermometer having not fewer than four divisions per °C over a temperature range of not less than 5°C above and below the standard temperature, and having an ice point for calibration.

NOTE 4—A thermometer short enough to be handled inside the balance case will be found convenient. ASTM Thermometer 23C (see Specification E1) and Anschutz-type thermometers have been found satisfactory for this purpose. Alternative thermometers with equivalent or better accuracy, precision, and properties while covering the temperature range of 6.4 are acceptable.

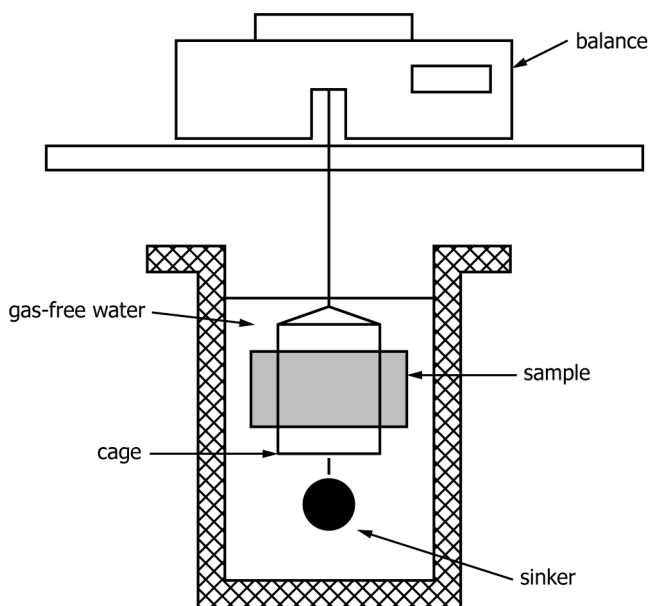

FIG. 1 Typical Configuration of Test Apparatus