



Designation: D4648/D4648M – 24

# Standard Test Methods for Laboratory Miniature Vane Shear Test for Saturated Fine-Grained Soil<sup>1</sup>

This standard is issued under the fixed designation D4648/D4648M; the number immediately following the designation indicates the year of original adoption or, in the case of revision, the year of last revision. A number in parentheses indicates the year of last reapproval. A superscript epsilon ( $\epsilon$ ) indicates an editorial change since the last revision or reapproval.

## 1. Scope\*

1.1 These test methods cover the miniature vane test in saturated fine-grained, cohesive clay and silt soils for the estimation of undrained shear strength. Knowledge of the nature of the soil in which each vane test is to be made is necessary for assessment of the applicability and interpretation of the test results. These test methods are not applicable to sandy soils or non-plastic silts, which may allow drainage during the test. These test methods are intended for soils which have an undrained shear strength less than 1.0 tsf [100 kPa].

NOTE 1—Vane failure conditions in higher strength clay and predominately silty soils may deviate from the assumed cylindrical failure surface, thereby causing error in the measured strength.

1.2 These test methods include the use of both conventional calibrated torque spring units (Method A) and electrical torque transducer units (Method B) with a motorized miniature vane shear device.

1.3 Laboratory vane is an ideal tool to investigate strength anisotropy in the vertical and horizontal directions, if suitable samples (specimens) are available.

1.4 The values stated in either inch-pound units or SI units [presented in brackets] are to be regarded separately as standard. The values stated in each system may not be exact equivalents; therefore, each system shall be used independently of the other. Combining values from the two systems may result in non-conformance with the standard. Reporting of test results in units other than inch-pound shall not be regarded as nonconformance with this standard.

1.4.1 The gravitational system of inch-pound units is used when dealing with inch-pound units. In this system, the pound (lbf) represents a unit of force (weight), while the unit for mass is slugs. The rationalized slug unit is not given, unless dynamic ( $F = ma$ ) calculations are involved.

<sup>1</sup> This test method is under the jurisdiction of ASTM Committee D18 on Soil and Rock and is the direct responsibility of Subcommittee D18.05 on Strength and Compressibility of Soils.

Current edition approved Jan. 15, 2024. Published February 2024. Originally approved in 1987. Last previous edition approved in 2016 as D4648/D4648M – 16. DOI: 10.1520/D4648\_D4648M-24.

1.5 All observed and calculated values shall conform to the guidelines for significant digits and rounding established in Practice D6026, unless superseded by this test method.

1.6 *This standard does not purport to address all of the safety concerns, if any, associated with its use. It is the responsibility of the user of this standard to establish appropriate safety, health, and environmental practices and determine the applicability of regulatory limitations prior to use.*

1.7 *This international standard was developed in accordance with internationally recognized principles on standardization established in the Decision on Principles for the Development of International Standards, Guides and Recommendations issued by the World Trade Organization Technical Barriers to Trade (TBT) Committee.*

## 2. Referenced Documents

2.1 *ASTM Standards:*<sup>2</sup>

D653 Terminology Relating to Soil, Rock, and Contained Fluids

D1587/D1587M Practice for Thin-Walled Tube Sampling of Fine-Grained Soils for Geotechnical Purposes (Withdrawn 2024)<sup>3</sup>

D2216 Test Methods for Laboratory Determination of Water (Moisture) Content of Soil and Rock by Mass

D2488 Practice for Description and Identification of Soils (Visual-Manual Procedures)

D2573/D2573M Test Method for Field Vane Shear Test in Saturated Fine-Grained Soils

D3740 Practice for Minimum Requirements for Agencies Engaged in Testing and/or Inspection of Soil and Rock as Used in Engineering Design and Construction

D4220/D4220M Practices for Preserving and Transporting Soil Samples (Withdrawn 2023)<sup>3</sup>

D6026 Practice for Using Significant Digits and Data Records in Geotechnical Data

<sup>2</sup> For referenced ASTM standards, visit the ASTM website, www.astm.org, or contact ASTM Customer Service at service@astm.org. For *Annual Book of ASTM Standards* volume information, refer to the standard's Document Summary page on the ASTM website.

<sup>3</sup> The last approved version of this historical standard is referenced on www.astm.org.

\*A Summary of Changes section appears at the end of this standard

**D6519/D6519M Practice for Sampling of Soil Using the Hydraulically Operated Stationary Piston Sampler**  
**D8121/D8121M Test Method for Approximating the Shear Strength of Cohesive Soils by the Handheld Vane Shear Device**

### 3. Terminology

#### 3.1 Definitions:

3.1.1 For definitions of common technical terms used in this standard, refer to Terminology **D653**.

#### 3.2 Definitions of Terms Specific to This Standard:

3.2.1 *torque spring, n*—an elastic spring that can be calibrated to provide a measure of torque that is proportional to the rotation (about a central longitudinal axis) of one end of the spring relative to a fixed condition at the opposite end of the spring.

### 4. Summary of Test Method

4.1 The miniature vane shear test consists of inserting a four-bladed vane in the end of an intact specimen from a tube sample or remolded specimen and rotating it at a constant rate to determine the torque required to cause a cylindrical surface to be sheared by the vane. This torque is then converted to a unit shearing resistance of the cylindrical surface area. The torque is measured by a calibrated torque spring or torque transducer that is attached directly to the vane.

### 5. Significance and Use

5.1 The miniature vane shear test may be used to obtain estimates of the undrained shear strength of fine-grained soils. The test provides a rapid determination of the undrained shear strength on undisturbed, or remolded or reconstituted soils.

NOTE 2—Notwithstanding the statements on precision and bias contained in this test method: The precision of this test method is dependent on the competence of the personnel performing it and the suitability of the equipment and facilities used. Agencies that meet the criteria of Practice **D3740** are generally considered capable of competent and objective testing. Users of this test method are cautioned that compliance with Practice **D3740** does not in itself ensure reliable testing. Reliable testing depends on several factors; Practice **D3740** provides a means for evaluating some of those factors.

### 6. Interferences

6.1 *Vane Disturbance*—The remolded zone around a vane blade resulting from insertion is generally assumed to be small and have little or no effect on the stress-strain properties of the sediment being tested. In reality, the volume of soil disturbed by the insertion of the vane blade into the assumed cylindrical volume of soil being tested may be significant. The vane shall displace no more than 15% of the soil being tested as defined by the maximum vane area ratio presented in **Fig. 1**.

### 7. Apparatus

7.1 *Vane Blade*—The vane assembly shall consist of four rectangular bladed vanes, as illustrated in **Fig. 2**. It is recom-

mended that the height of the vane be twice the diameter (2:1), although vanes with a height equal to the diameter (1:1) also may be used (see **Note 3**). Vane blade diameter ( $D$ ) may vary from 0.50 to 1.0 in. [12.7 to 25.4 mm].

7.2 *Vane Device*—The vane device should be motorized and, in the case of a torque spring device, shall rotate the torque spring at a constant rate of 60 to 90°/min [1.0 to 1.6 rad/min]. A vane device which applies the torque directly through a stiff shaft using an electrical transducer to measure torque shall rotate the vane at a constant rate that ranges from 20 to 30°/min [0.35 to 0.52 rad/min]. The vane/spring rotation device shall have an indicator or recording system that displays/records deflection (torque) of the calibrated spring or electrical transducer and, where possible, vane blade rotation.

7.3 *Torque Measuring Device*—The torque measuring device shall be a conventional torque spring, electrical torque transducer, or any other measuring device capable of the accuracy prescribed herein and may be part of the vane device. The torque measuring device shall be capable of measuring the torque to at least three significant digits. Undrained shear strength estimated by a hand-held vane (Test Methods **D8121/D8121M**) is often used to assist in selection of the appropriate spring or torque transducer range and accuracy.

NOTE 3—Since many clays are anisotropic with respect to strength, the relative importance of horizontal, as distinct from vertical, shearing surfaces can influence the test results. For this reason it is important that the recommended ratio of height to diameter be respected unless the intent is to vary the ratio in order to determine the horizontal and vertical strengths separately. For more detailed discussion on effects of height to diameter ratio as well as vane shape, refer to Refs. (1) and (2).<sup>4</sup>

### 8. Preparation and Testing of Specimens

8.1 *Specimen Size*—Specimens should have a diameter sufficient to allow clearance of at least two blade diameters between all points on the circumference of the shearing surface and the outer edge of the sample.

8.2 *Intact Vane Strength*—Prepare intact specimens from intact samples secured in accordance with Practice **D1587/D1587M** or **D6519/D6519M**, and handle and transport in accordance with the practices for Group C and D Samples in Practices **D4220/D4220M**. Tests may be run in the sampling tube, eliminating the need for extrusion. Handle specimens carefully to prevent disturbance or loss of water (moisture) content. Trim flat the end of the sample where the vane will be inserted. The specimen surface shall be perpendicular to the wall of the tube and parallel to the leading, horizontal edge of the vane.

8.3 *Remolded Vane Strength*—Conduct remolded miniature vane strength tests on failed specimens similar to remolded field vane tests (Test Method **D2573/D2573M**) by rotating the

<sup>4</sup> The boldface numbers in parentheses refer to the list of references at the end of this standard.

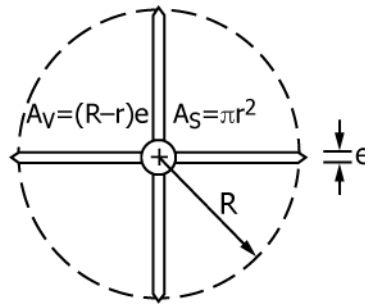

$$V_A = \frac{4(R-r)e + \pi r^2}{\pi R^2} \times 100$$

Where :  $V_A$  = Vane Area Ratio (%)  
 $R$  = Radius of Failure Cylinder (in or mm)  
 $r$  = Radius of Vane Shaft (in or mm)  
 $e$  = Vane Blade Thickness (in or mm)

VANE TYPE	BLADE DIA. in [mm]	SHAFT DIA. in [mm]	BLADE THICKNESS in [mm]	AREA RATIO (%)
Miniature	0.50 [12.7]	0.1275 [3.5]	0.019 [0.5]	13.7 [14.9]

FIG. 1 Vane Area Ratio for ASTM Vanes

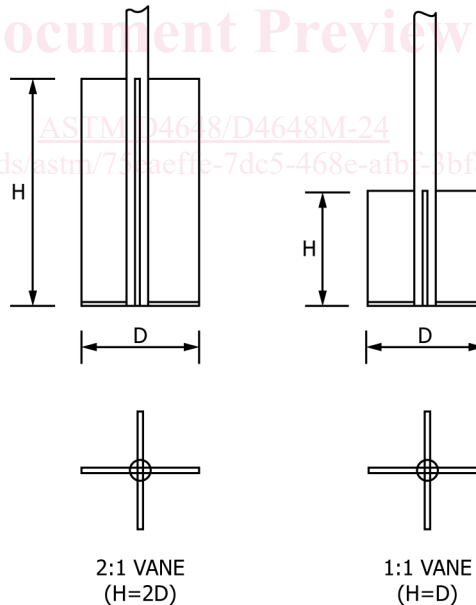

FIG. 2 Miniature Vane Blade Geometry

vane rapidly through a minimum of five to ten revolutions after intact vane strength is determined, and then repeating the test procedure.

NOTE 4—Remolded undrained shear strength measurements are conventionally obtained by conducting strength tests on specimens encased in a thin rubber membrane, to prevent change in water content, and remolded by hand (hand remolding). Field vane remolded strength has however

been obtained by rotating the vane rapidly through a minimum of five to ten complete revolutions and conducting a vane test within 1 min of the remolding process (machine remolding). A machine remolded test yields a vane strength value that is considered more a residual strength. The machine remolded strength is typically higher than the hand remolded strength and, as a consequence, produces lower sensitivities. In many sensitive clayey soils, residual strengths may be obtained within one to two revolutions or less. If such soils are being tested, it is recommended

that several remolded strengths be obtained using the standard five to ten revolutions for verification. If no major remolded strength differences are noted, remolded strengths may be obtained at less than the recommended five to ten revolutions.

NOTE 5—In cases where electrical torque transducers with wires for signal transmission are utilized, the remolded miniature vane strength may be obtained by rotating the vane one complete revolution in one direction and then again in the opposite direction a number of times to produce the desired five to ten complete revolutions.

## 9. Preparation of Apparatus

9.1 *Vane Blade Damage*—Carefully check each vane prior to each use for bent shafts and blades and imperfections that could alter the vane failure surface from the assumed cylindrical surface.

## 10. Calibration

10.1 Conduct periodic calibration of the spring units (or torque transducers) to ensure proper operation of the miniature vane device and repeatability of the torque spring or transducers. Calibration is accomplished by the application of calibrated weights onto a calibrated wheel to produce a known torque (lever arm  $\times$  weight). Secure the vane shear unit in such a way that the vane spring (torque unit) is in a horizontal position. Then insert the calibration wheel in place of the vane blade. The calibration wheel, calibration string, and calibration weights all shall hang free of any obstructions. Dimensions of the calibration wheel shall be noted; specifically the lever arm.

10.2 For each vane torque spring to be used, apply a series of calibration weights to the calibration wheel to develop a plot of spring rotation (in degrees) versus torque (in lbf-in. or [N-m]). Carefully fasten each calibration weight to the calibration string and allow to deflect the spring. Record the deflection of the spring (in degrees) and applied torque for each weight applied. The calibration wheel configuration, lever arm, weights, and resulting torque shown in Fig. 3 is recommended for consideration in the calibration procedure.

10.3 Conduct periodic measurements of the vane blade dimensions (height, diameter, and thickness) and vane shaft diameter with a maximum interval between measurements of one year. Record measurements to the nearest 0.01 in. [0.1 mm] for blade height and diameter, and to the nearest 0.001 in. [0.01 mm] for blade thickness and vane shaft diameter. At a minimum, record and average four measurements of each blade dimension at unique locations on the vane. The height and thickness of each blade shall be measured, and the diameter of the vane blades shall be measured using the two opposing blade pairs. Verify that the vane blade measurements and shaft cross-sectional area result in a vane area ratio that meets the maximum allowable value in 6.1.

## 11. Application and Measurement of Vane Blade Torque

11.1 Apply the torque to the vane by a conventional torque spring (Fig. 4a) or an electrical torque transducer (Fig. 4b) that is rotated with the vane/spring rotation device. The torque spring or transducer shall produce a repeatable linear relationship between spring rotation (degrees) or transducer output (mV) and torque applied.

NOTE 6—Since vane strength may be greatly influenced by the rate at

which shear occurs, it is recommended that torque be applied using a motorized vane device. A hand crank manual device may be utilized, but is not recommended due to the potential variation in rate of shear.

NOTE 7—When the miniature vane test is conducted using a calibrated torque spring, the top of the spring unit is rotated at a constant rotation rate while the bottom of the spring most often remains stationary or nearly stationary until enough energy (torque) is built up in the spring. Just prior to or at failure, the bottom of the spring and vane begin to rotate (generally slowly) as failure begins. The torque applied by the spring soon overcomes the shearing resistance of the soil and the vane blade rotates rapidly to bring the soil to total failure. Thus, depending upon the stiffness of the calibrated torque spring, soil strength, and consistency, the rate of shear and possibly the undrained shear strength may vary.

NOTE 8—It should be recognized that there is a fundamental difference in the failure modes between miniature vane tests made using a calibrated torque spring and an electrical transducer. An electrical torque transducer will produce a strain-controlled failure of the soil, whereas a calibrated torque spring will produce failure that varies somewhere between purely stress-controlled and strain-controlled conditions. Using an electrical torque transducer, the constant rate of rotation applied to the top of the torque transducer is transmitted directly to the vane blade. The resulting strain-controlled failure could result in a higher rate of shear than that produced using a calibrated torque spring.

## 12. Vane Rotation and Shearing Rate

12.1 Apply rotational displacement to the vane/spring at a constant rate within the ranges identified in 7.2. Select the combination of torque spring or vane rotation rates to cause specimen to reach failure within 2 to 5 min (see Note 9).

NOTE 9—The rate of vane rotation has two major effects on the resulting measured vane shearing strength. The first is preventing drainage so that a truly undrained shear strength is measured. The second resembles a viscous effect: the faster a soil is sheared the higher is its measured strength. There are currently two approaches for determining the vane rotation and shearing rate. These approaches are (1) angular shear velocity approach, and (2) Blight's drainage approach. A more detailed discussion of these two approaches can be found in Refs. (3) and (4), respectively.

## 13. Procedure

13.1 Fasten the vane shear unit, as well as the specimen container, securely to a table or frame to prevent movement during a test. Zero the spring or take an initial reading of the torque. Insert the vane in the sample to a minimum depth equal to twice the height of the vane blade to ensure that the top of the vane blade is embedded at least one vane blade height below the sample surface (see Note 10).

NOTE 10—If a very long-shafted vane (soil-embedded shaft length is more than twice the vane height) is employed to test within a sample, then the adhesion between the shaft above the vane and the soil should be evaluated. The adhesion is evaluated by inserting a shaft, without the vane, having the same dimensions as the actual vane shaft, into the soil to the level to be tested and noting the resulting torque versus rotation. The torque is subtracted from actual test results. To eliminate this correction, the actual torque shaft can be encased in a frictionless sleeve to prevent adhesion from occurring.

13.2 Hold the sample firmly to prevent rotation. Initiate mechanically rotation of the vane so as to rotate the top of the spring or transducer at a constant rate in accordance with 12.1. Record spring deflection or torque transducer readings at least every 5° of rotation until the spring deflection does not increase (which is considered failure) or until a maximum of 90° of rotation is obtained. During the rotation of the vane, hold the vane blade at a fixed elevation. Record the rotation rate, maximum torque and intermediate torque readings if required.