



Designation: **D5306–92 (Reapproved 2018) D5306 – 24**

Standard Test Method for Linear Flame Propagation Rate of Lubricating Oils and Hydraulic Fluids¹

This standard is issued under the fixed designation D5306; the number immediately following the designation indicates the year of original adoption or, in the case of revision, the year of last revision. A number in parentheses indicates the year of last reapproval. A superscript epsilon (ϵ) indicates an editorial change since the last revision or reapproval.

1. Scope*

1.1 This test method covers the determination of the linear flame propagation rates of lubricating oils and hydraulic fluids supported on the surfaces of and impregnated into ceramic fiber media. Data thus generated are to be used for the comparison of relative flammability.

1.2 This test method should be used to measure and describe the properties of materials, products, or assemblies in response to heat and flame under controlled laboratory conditions and should not be used to describe or appraise the fire hazard or fire risk of materials, products, or assemblies under actual fire conditions. However, results of this test method may be used as elements of fire risk which takes into account all of the factors that are pertinent to an assessment of the fire hazard of a particular end use.

1.3 The values stated in SI units are to be regarded as standard. No other units of measurement are included in this standard.

1.4 *This standard does not purport to address all of the safety concerns, if any, associated with its use. It is the responsibility of the user of this standard to establish appropriate safety, health, and environmental practices and determine the applicability of regulatory limitations prior to use.*

1.5 *This international standard was developed in accordance with internationally recognized principles on standardization established in the Decision on Principles for the Development of International Standards, Guides and Recommendations issued by the World Trade Organization Technical Barriers to Trade (TBT) Committee.*

2. Referenced Documents

2.1 *ASTM Standards:*²

[D4175 Terminology Relating to Petroleum Products, Liquid Fuels, and Lubricants](#)

[E691 Practice for Conducting an Interlaboratory Study to Determine the Precision of a Test Method](#)

2.2 *Military Specifications:*³

[MIL-H-83282C Hydraulic Fluid, Fire Resistant, Synthetic Hydrocarbon Base, Aircraft NATO Code Number H-537](#)

[MIL-H-46170B Amm.1, Hydraulic Fluid, Rust Inhibited, Fire Resistant, Synthetic Hydrocarbon Base](#)

3. Terminology

3.1 *Definitions:*

¹ This test method is under the jurisdiction of ASTM Committee D02 on Petroleum Products, Liquid Fuels, and Lubricants and is the direct responsibility of Subcommittee D02.N0 on Hydraulic Fluids.

Current edition approved Oct. 1, 2018; March 1, 2024. Published November 2018; March 2024. Originally approved in 1992. Last previous edition approved in 2013 as D5306 – 92 (2013) (2018). DOI: [10.1520/D5306-92R18-10.1520/D5306-24](https://doi.org/10.1520/D5306-92R18-10.1520/D5306-24).

² For referenced ASTM standards, visit the ASTM website, www.astm.org, or contact ASTM Customer Service at service@astm.org. For *Annual Book of ASTM Standards* volume information, refer to the standard's Document Summary page on the ASTM website.

³ Available from DLA Document Services, Bldg. 4, Section D, 700 Robbins Ave., Philadelphia, PA 19111-5094, <https://assist.dla.mil/online/start>.

*A Summary of Changes section appears at the end of this standard

3.1.1 For definitions of terms used in this test method, refer to Terminology D4175.

3.2 Definitions of Terms Specific to This Standard:

3.2.1 *linear flame propagation rate, n*—the average quotient of the distance of flame travel and the time required for the flame front to travel that distance.

4. Summary of Test Method

4.1 A section of a ceramic fiber support medium (string) is impregnated with the sample under specific conditions. The impregnated fiber is placed on a standard support. The sample is ignited and the time required for the flame front to propagate across a measured distance is determined by use of a thermoelectric system. The average propagation rate is then calculated from the measured distance of flame travel and the time required for the flame front to propagate over that distance.

5. Significance and Use

5.1 The linear flame propagation rate of a sample is a property that is relevant to the overall assessment of the flammability or relative ignitability of fire resistance lubricants and hydraulic fluids. It is intended to be used as a bench-scale test for distinguishing between the relative resistance to ignition of such materials. It is not intended to be used for the evaluation of the relative flammability of flammable, extremely flammable, or volatile fuels, solvents, or chemicals.

6. Apparatus

6.1 Apparatus for measurement of linear flame propagation rates:

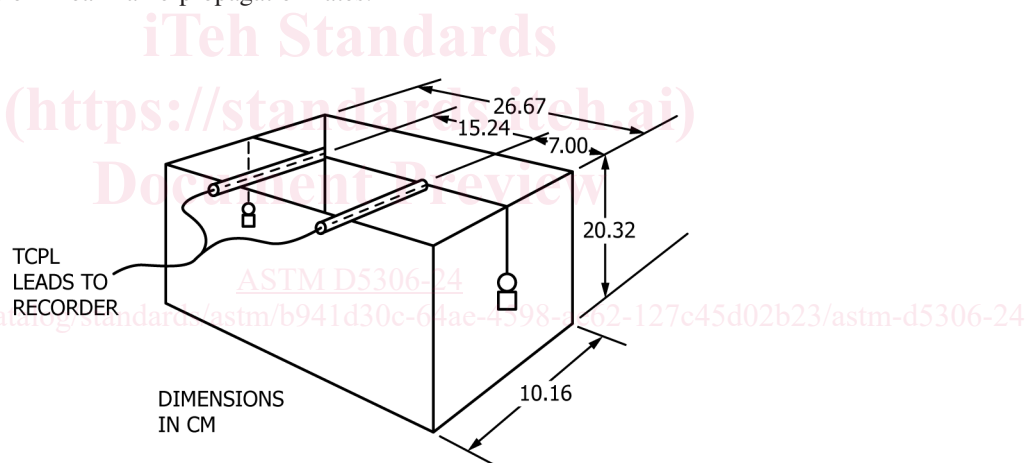

FIG. 1 Apparatus for Determination of Linear Flame Propagation Rates

6.1.1 *Open Top Stainless Steel Box*, as shown in Fig. 1.

6.1.2 *Recorder*, stripchart, fast responses. A zero-centered recorder with a ± 5 mV range and a one-half second full-scale deflection capacity has been found to be satisfactory. A chart speed of at least 1 in./min has been used for most studies.

6.1.3 *Differential Thermocouple Pair*, 30 gauge with bare junctions and double fiberglass wrap insulation, ISA, Type J or Type K may be prepared from any premium grade thermocouple wire.

6.1.4 *Fume Hood*, draft-free when ventilation system is not operative.

6.1.5 *Weights*, 50 g \pm 0.01 g, with attached hooks; two required.

6.1.6 *Chrome-Plated Tube or Rod*, 15 mm diameter by 375 mm long.

6.1.7 *Porcelain or Glass Dish*, approximately 135 mL capacity.

7. Materials

7.1 *Absorbent Paper Wipers*, 375 mm by 213 mm.

7.2 *Ceramic Fiber*,⁴twisted yarn type 390/312, 4/5, 2.72 or type 390/312, 3/4, 2.72. Ceramic fiber size used shall be agreed upon by supplier and consumer and shall be specified in test report.

7.3 *Ignition Source*, any paper book matches or wooden kitchen matches can be used.

8. Procedure

8.1 Tie small loops in each end of a 500 mm section of ceramic fiber support (string). Place a few millilitres of the sample to be studied in an evaporating dish. Immerse the ceramic fiber support (string) in the liquid sample for 60 s. Avoid immersion of the loops at the end of the string.

8.2 While the ceramic fiber support (string) is immersed in the sample, carefully wrap an absorbent paper wiper around the 15 mm diameter chrome plated rod. Leave one end of the rod uncovered by the wiper.

8.3 Remove the ceramic fiber support (string) section from the liquid sample and attach a 50 g weight to the loop at each end. Fix the chrome-plated rod with its absorbent paper wrapping in a horizontal position and hang the soaked string section with attached weights over the unwrapped section of the rod. Press down gently on the uppermost weight to cause the soaked string to pass over the bare rod, flexing gently as it moves. When the lower weight has been drawn up to the rod, reverse the process until the first weight has again been drawn up the rod. Repeat the cycle four times to work the sample thoroughly into the string.

8.4 Transfer the string with attached weights to the covered portion of the chrome-plated rod. Pass the string over the absorbent paper in the manner described in 8.3. After each complete double cycle, lift the string from the paper, rotate it through 180° as it is held taut in a vertical position and then replace it on a fresh area of the absorbent medium. Again pass the string over the paper in the manner described in 8.3. Repeat until four double cycles have been completed.

8.5 Place the string support and thermocouple holder in a draft-free hood with the ventilation turned off. Level the apparatus with a spirit level. Place the prepared string on the string supports. The attached weights should be left in place to provide tension in the string. Adjust the differential thermocouple junctions so that they are exactly 2 mm directly above the string. Connect the differential thermocouple pair to the fast-response, zero-centered strip chart recorder.

8.6 Start the recorder chart after an appropriate warm-up period. With an ignition source, ignite the sample on the string near its support at one end of the apparatus. Permit the flame to advance along the string past each thermocouple until it extinguishes itself upon reaching the opposite string support. Stop the recorder and start the hood ventilator to exhaust the combustion products of the sample. (**Warning**—Take extreme care to avoid inhalation of the combustion products as extremely toxic substances are formed during the combustion of some synthetic materials, especially halogenated and phosphorus-based compounds.)

8.7 Measure the horizontal distance between the thermocouples and interval between the first thermal effects as shown in Fig. 2. From the measured interval, the chart speed of the recorder and the known horizontal distance between thermocouples in the test apparatus, calculate and report the horizontal linear flame propagation rate in millimetres per second. If the flame does not advance during the experimental run, or if it extinguishes itself before passing both thermocouples, record that fact. Replicate runs shall be made as required.

9. Calculation and Report

9.1 Calculate the linear flame propagation rate as follows:

$$\text{linear flame propagation rate} = \frac{dv}{p} \quad (1)$$

⁴ The sole source of supply of the ceramic fiber known to the committee at this time is Nextel Ceramic Fiber, manufactured by the 3M Company, 219-1-1, 3M Center, St. Paul, MN 55144. If you are aware of alternative suppliers, please provide this information to ASTM International Headquarters. Your comments will receive careful consideration at a meeting of the responsible technical committee,¹ which you may attend.