



**SLOVENSKI STANDARD**  
**SIST ISO 5658-2:1999**  
**01-september-1999**

---

DfYg\_i gj`cXn]j UbUc[ Yb^E`ü]f^Yb^Y`d`Ua YbUË`&`XY. JnXc`ÿbc`ý]f^Yb^Y`d`Ua YbUdc  
dc\_cb b] [ fUXVYb] `dfc]nj cX]

Reaction to fire tests -- Spread of flame -- Part 2: Lateral spread on building products in vertical configuration

**iTeh STANDARD PREVIEW**

Essais de réaction au feu -- Propagation du feu -- Partie 2: Propagation latérale sur les produits de bâtiment en position verticale

[SIST ISO 5658-2:1999](https://standards.iteh.ai/catalog/standards/sist/406f1bed-fe4b-4068-afa1-2b19435acd6d/sist-iso-5658-2-1999)

Ta slovenski standard je istoveten z: **ISO 5658-2:1996**

---

**ICS:**

13.220.50	Požarna odpornost gradbenih materialov in elementov	Fire-resistance of building materials and elements
-----------	---	--

**SIST ISO 5658-2:1999**

**en**

**iTeh STANDARD PREVIEW**  
**(standards.iteh.ai)**

SIST ISO 5658-2:1999

<https://standards.iteh.ai/catalog/standards/sist/406f1bed-fe4b-4068-afa1-2bf3435acd6d/sist-iso-5658-2-1999>

# INTERNATIONAL STANDARD

**ISO**  
**5658-2**

First edition  
1996-08-01

---

---

## **Reaction to fire tests — Spread of flame —**

### **Part 2:**

Lateral spread on building products in vertical configuration

**iTeh STANDARD PREVIEW**

*Essais de réaction au feu — Propagation du feu —*

*(Partie 2: Propagation latérale sur les produits de bâtiment en position verticale)*

[SIST ISO 5658-2:1999](https://standards.iteh.ai/catalog/standards/sist/406f1bed-fe4b-4068-afa1-2bf3435acd6d/sist-iso-5658-2-1999)

<https://standards.iteh.ai/catalog/standards/sist/406f1bed-fe4b-4068-afa1-2bf3435acd6d/sist-iso-5658-2-1999>



Reference number  
ISO 5658-2:1996(E)

<b>Contents</b>	Page
1 Scope.....	1
2 Normative reference.....	1
3 Definitions.....	1
4 Principles of the test.....	2
5 Suitability of a product for testing.....	2
6 Test specimens .....	3
7 Test apparatus .....	5
8 Test environment .....	9
9 Additional equipment and instrumentation.....	9
10 Setting-up and calibration procedure .....	12
11 Test procedure .....	16
12 Expression of fire performance of a product.....	17
13 Test report .....	17
<b>Annexes</b>	
A Safety precautions.....	18
B Specimen construction.....	19
C Calibration of the working heat flux meter .....	20
D Guidelines for reporting and follow-up of results of fire test procedures.....	21
E Variability of test results .....	22
F Bibliography .....	23

© ISO 1996

All rights reserved. Unless otherwise specified, no part of this publication may be reproduced or utilized in any form or by any means, electronic or mechanical, including photocopying and microfilm, without permission in writing from the publisher.

International Organization for Standardization  
Case postale 56 • CH-1211 Genève 20 • Switzerland

Printed in Switzerland

## Foreword

ISO (the International Organization for Standardization) is a worldwide federation of national standards bodies (ISO member bodies). The work of preparing International Standards is normally carried out through ISO technical committees. Each member body interested in a subject for which a technical committee has been established has the right to be represented on that committee. International organizations, governmental and non-governmental, in liaison with ISO, also take part in the work. ISO collaborates closely with the International Electrotechnical Commission (IEC) on all matters of electrotechnical standardization.

Draft International Standards adopted by the technical committees are circulated to the member bodies for voting. Publication as an International Standard requires approval by at least 75 % of the member bodies casting a vote.

International Standard ISO 5658-2 was prepared by Technical Committee ISO/TC 92, *Fire safety*, Subcommittee SC 1, *Reaction to fire*.

[SIST ISO 5658-2:1999](https://standards.iteh.ai/catalog/standards/sist/5658-2-1999)

<https://standards.iteh.ai/catalog/standards/sist/5658-2-1999> ISO 5658 consists of the following parts, under the general title *Reaction to fire tests — Spread of flame*:

- *Part 1: Guidance on flame spread*  
(Technical Report)
- *Part 2: Lateral spread on building products in vertical configuration*
- *Part 3: Lateral ignition and flame spread of building products in vertical configuration (LIFT) method*  
(Technical Report)
- *Part 4: Intermediate scale spread of flame*

Annex A forms an integral part of this part of ISO 5658. Annexes B to F are for information only.

## Introduction

This part of ISO 5658 is based on the method of the International Maritime Organization (IMO) published as IMO Resolution A.653(16)<sup>[5]</sup>, and has been developed as an International Standard in order to allow its wider use. The major differences between ISO 5658-2 and the IMO test are that ISO 5658-2 is limited in scope to testing the spread of flame over vertical specimens and does not include the stack for estimating heat release rate.

ISO/TR 5658-1 describes the development of standard tests for flame spread and explains the theory of flame spread for various orientations. The relationship, both theoretical and mathematical, which exists between ISO 5658-2 and ISO/TR 5658-3 is also explained.

ISO 5658-2 provides a simple method by which lateral surface spread of flame on a vertical specimen can be determined for comparative purposes. This method is particularly useful for research, development and quality control purposes.

ISO/TR 5658-3 provides a more scientific method by which the ignitability and spread of flame parameters of building products can be determined. The data derived from this test are suitable for use in fire growth (mathematical) models. The same test apparatus is used for the procedures specified in this part of ISO 5658 and ISO/TR 5658-3.

Fire is a complex phenomenon: its behaviour and its effects depend upon a number of interrelated factors. The behaviour of materials and products depends upon the characteristics of the fire, the method of use of the materials and the environment to which they are exposed. The methodology of "reaction to fire" tests is explained in ISO/TR 3814<sup>[1]</sup>.

A test such as is specified in this part of ISO 5658 deals only with a simple representation of a particular aspect of the potential fire situation typified by a radiant heat source and flame; it cannot alone provide any direct guidance on behaviour or safety in fire.

A precision statement based on an interlaboratory trial using this test method is given in annex E.

This test procedure does not rely on the use of asbestos-based materials.

The attention of all users of the test is drawn to the following caution.

**CAUTION — So that suitable precautions may be taken to safeguard health, the attention of all concerned in fire tests is drawn to the possibility that toxic or harmful gases may be evolved during exposure of test specimens. The advice on safety given in annex A should also be noted.**

# Reaction to fire tests — Spread of flame —

## Part 2:

## Lateral spread on building products in vertical configuration

### 1 Scope

**1.1** This part of ISO 5658 specifies a method of test for measuring the lateral spread of flame along the surface of a specimen of a product orientated in the vertical position. It provides data suitable for comparing the performance of essentially flat materials, composites or assemblies, which are used primarily as the exposed surfaces of walls.

**1.2** This part of ISO 5658 is applicable to the measurement and description of the properties of materials, products or assemblies in response to radiative heat in the presence of a pilot flame under controlled laboratory conditions. It should not be used alone to describe or appraise the fire hazard or fire risk of materials, products or assemblies under actual fire conditions.

### 2 Normative reference

The following standard contains provisions which, through reference in this text, constitute provisions of this part of ISO 5658. At the time of publication, the edition indicated was valid. All standards are subject to revision, and parties to agreements based on this part of ISO 5658 are encouraged to investigate the possibility of applying the most recent edition of the standard indicated below. Members of IEC and ISO maintain registers of currently valid International Standards.

ISO/IEC Guide 52:1990, *Glossary of fire terms and definitions*.

### 3 Definitions

For the purposes of this part of ISO 5658, the definitions given in ISO/IEC Guide 52 and the following definitions apply.

**3.1 assembly:** Fabrication of materials and/or composites, for example sandwich panels.

NOTE 1 The assembly may include an air gap.

**3.2 average heat for sustained burning:** Average of the values of heat for sustained burning, expressed in megajoules per square metre (MJ/m<sup>2</sup>), measured at a number of specified positions.

**3.3 backing board:** Non-combustible board with the same dimensions as the specimen, used in every test to back the specimen (see 9.7).

**3.4 composite:** Combination of materials which are generally recognized in building construction as discrete entities, for example coated or laminated materials.

**3.5 critical heat flux at extinguishment:** Incident heat flux, expressed in kilowatts per square metre (kW/m<sup>2</sup>), at the surface of a specimen at the point along its horizontal centreline where the flame ceases to advance and may subsequently go out. The heat flux value reported is based on interpolations of measurements with a non-combustible calibration board.

**3.6 exposed surface:** That surface of the specimen subjected to the heating conditions of the test.

**3.7 flame front:** Furthest extent of travel of a sustained flame centrally along the length of the test specimen.

**3.8 flashing:** Existence of flame on or over the surface of the specimen for periods of less than 1 s.

**3.9 heat for sustained burning:** Product of the time from the start of exposure of a specimen to the arrival of the flame front at a specified position and the incident radiant heat flux corresponding to that position measured on a non-combustible calibration board. Expressed in megajoules per square metre (MJ/m<sup>2</sup>).

NOTE 2 The positions are specified in table 1 (see clause 10).

**3.10 irradiance** (at a point of a surface): Quotient of the radiant heat flux incident on an infinitesimal element of surface containing the point, by area of that element.

**3.11 material:** Single substance or uniformly dispersed mixture, for example metal, stone, timber, concrete, mineral fibre, polymers.

**3.12 product:** Material, composite or assembly about which information is required.

**3.13 radiant heat flux:** Power emitted, transferred or received in the form of radiation.

**3.14 specimen:** Representative piece of the product which is to be tested together with any substrate or treatment.

NOTE 3 The specimen may include an air gap.

**3.15 spread of flame:** Propagation of a flame front over the surface of a product under the influence of imposed irradiance.

**3.16 substrate:** Material which is used, or is representative of that used, immediately beneath a surface product, e.g. skimmed plasterboard beneath a wall-covering.

**3.17 sustained flaming:** Existence of flame on or over the surface of the specimen for periods of more than 4 s.

**3.18 transitory flaming:** Existence of flame on or over the surface of the specimen for periods of between 1 s and 4 s.

**3.19 lateral spread of flame:** Progression of the flame front in a lateral direction over the specimen length.

## 4 Principles of the test

**4.1** The test method consists of exposing conditioned specimens in a well-defined field of radiant

heat flux and measuring the time of ignition, the lateral spread of flame, and its final extinguishment.

**4.2** A test specimen is placed in a vertical position adjacent to a gas-fired radiant panel where it is exposed to a defined field of radiant heat flux. A pilot flame is sited close to, but usually not contacting, the hotter end of the specimen to ignite volatile gases issuing from the surface (see figure 1).

**4.3** Following ignition, any flame front which develops is noted and a record is made of the progression of the flame front horizontally along the length of the specimen in terms of the time it takes to travel various distances.

**4.4** The results are expressed in terms of flame spread distance versus time, flame front velocity versus heat flux, the critical heat flux at extinguishment and the average heat for sustained burning.

## 5 Suitability of a product for testing

### 5.1 Surface characteristics

**5.1.1** A product having one of the following characteristics is suitable for evaluation using this method:

- a) an essentially flat exposed surface, i.e. all surface irregularities are within  $\pm 1$  mm of plane;
- b) a surface irregularity which is evenly distributed over the exposed surface provided that
  - 1) at least 50 % of the surface of a representative square area, 155 mm by 155 mm, lies within a depth of 6 mm from a plane across the highest points of the exposed surface, and/or
  - 2) any cracks, fissures or holes do not exceed 8 mm in width or 10 mm in depth and the total area of such cracks, fissures or holes at the surface does not exceed 30 % of a representative square area, 155 mm by 155 mm, of the exposed surface.

**5.1.2** Where a product has areas of its surface which are distinctly different, but each of these separate areas satisfies the surface characteristics specified in 5.1.1, then each of these separate areas shall be tested to evaluate fully the product.

**5.1.3** When an exposed surface does not comply with the requirements of either 5.1.1 a), or 5.1.1 b), the product may be tested in a modified form with an essentially flat exposed surface. The modification shall be stated in the report.



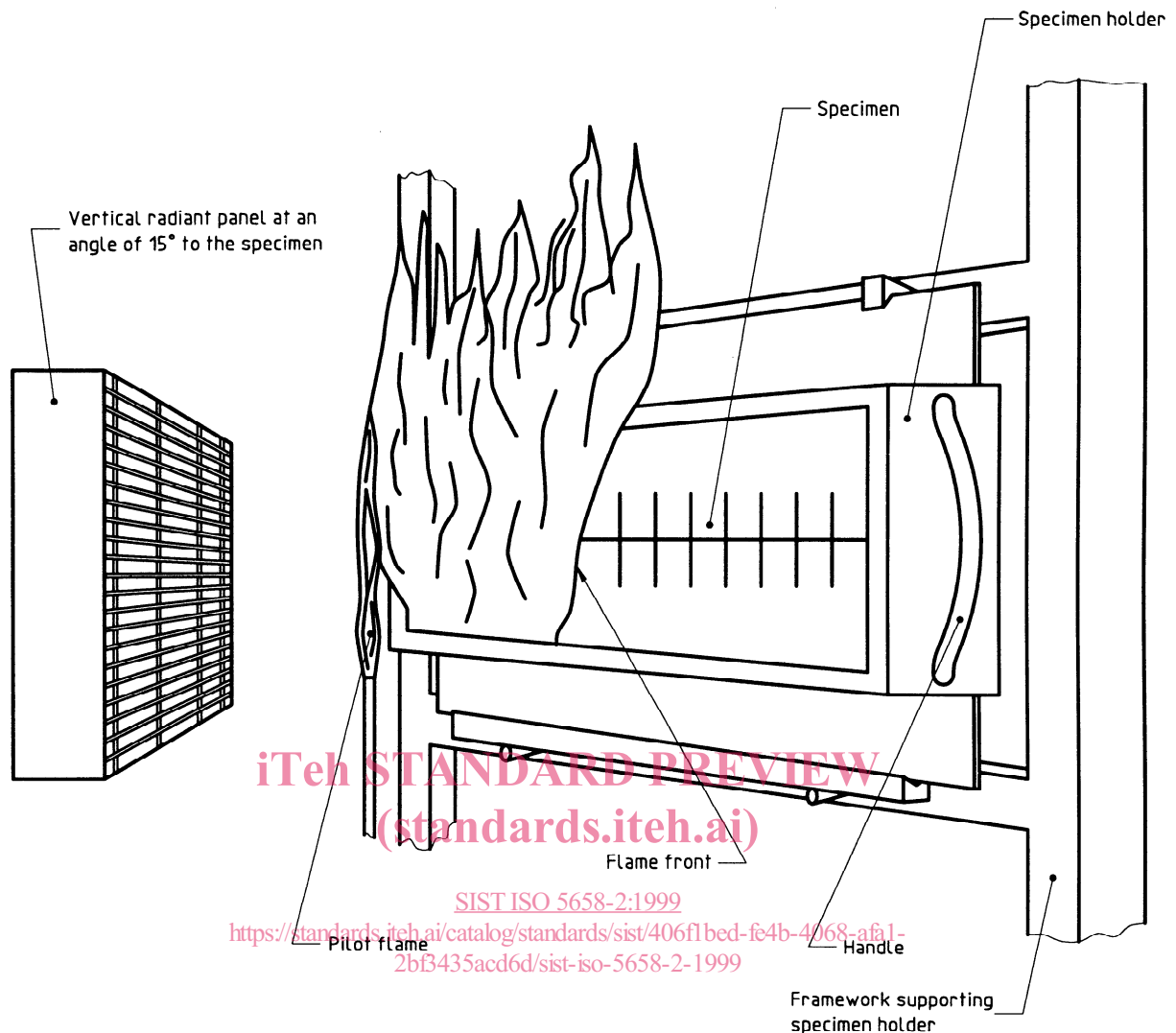

Figure 1 — Schematic of test

## 5.2 Thermally unstable products

The test method may not be suitable for assessing products that react in particular ways under exposure to the specified heating conditions (see 11.12). Products showing these characteristics should be assessed using other test methods, as given in, for example, ISO 9705.

## 6 Test specimens

### 6.1 The exposed surface

The product shall be tested on that face which will normally be exposed in use, taking account of the following.

- a) If it is possible for either or both of the faces to be exposed in use then, if the core is asymmetrical, both faces shall be tested.
- b) If the face of the product contains a surface irregularity that is specifically directional, e.g. corrugations, grain or machine-induced orientation which may, in use, run horizontally or vertically, the product shall be tested in both orientations.
- c) If the exposed face contains distinct areas of different surface finish or texture, then the appropriate number of specimens shall be provided for each distinct area of such finish or texture to be evaluated.
- d) Textile materials shall be tested for spread of flame in both the warp and the weft directions.
- e) If a bright metallic-faced specimen is to be tested, it shall be tested both as-received and also finished with a thin coat of lamp black or colloidal graphite, applied before conditioning for test.

## 6.2 Number and size of specimens

**6.2.1** At least six specimens shall be provided for test.

**6.2.2** Three specimens shall be tested for each potentially exposed surface or orientation.

With specimens which could be exposed from either side and also having directional irregularities on one side only, at least nine specimens will be needed, i.e. three for testing with the irregularities vertical, three with the irregularities horizontal and three for testing the opposite side which is smooth.

**6.2.3** The specimens shall be  $800\text{ mm} \pm 5\text{ mm}$  long by  $155\text{ mm} \pm 5\text{ mm}$  wide and shall be representative of the product.

**6.2.4** The thickness of specimens of products with irregular surfaces (see 6.1) shall be measured from

the highest point of the surface. Products of thickness 50 mm or less, shall be tested using their full thickness. For products of normal thickness greater than 70 mm, the unexposed face shall be cut away to reduce the thickness to  $70\text{ mm} \pm 3\text{ mm}$ .

For products of thicknesses in the range of 50 mm to 70 mm, it is necessary to use an extension clip or restraint at the rear of the specimen holder (see figure 2).

## 6.3 Construction of specimens

**6.3.1** For thin materials or composites used in the fabrication of an assembly, the presence of air or an air gap and/or the nature of any underlying construction may significantly affect the characteristics of the exposed surface. The influence of the underlying layers should be understood and care taken to ensure that the test result obtained on any assembly is relevant to its use in practice.

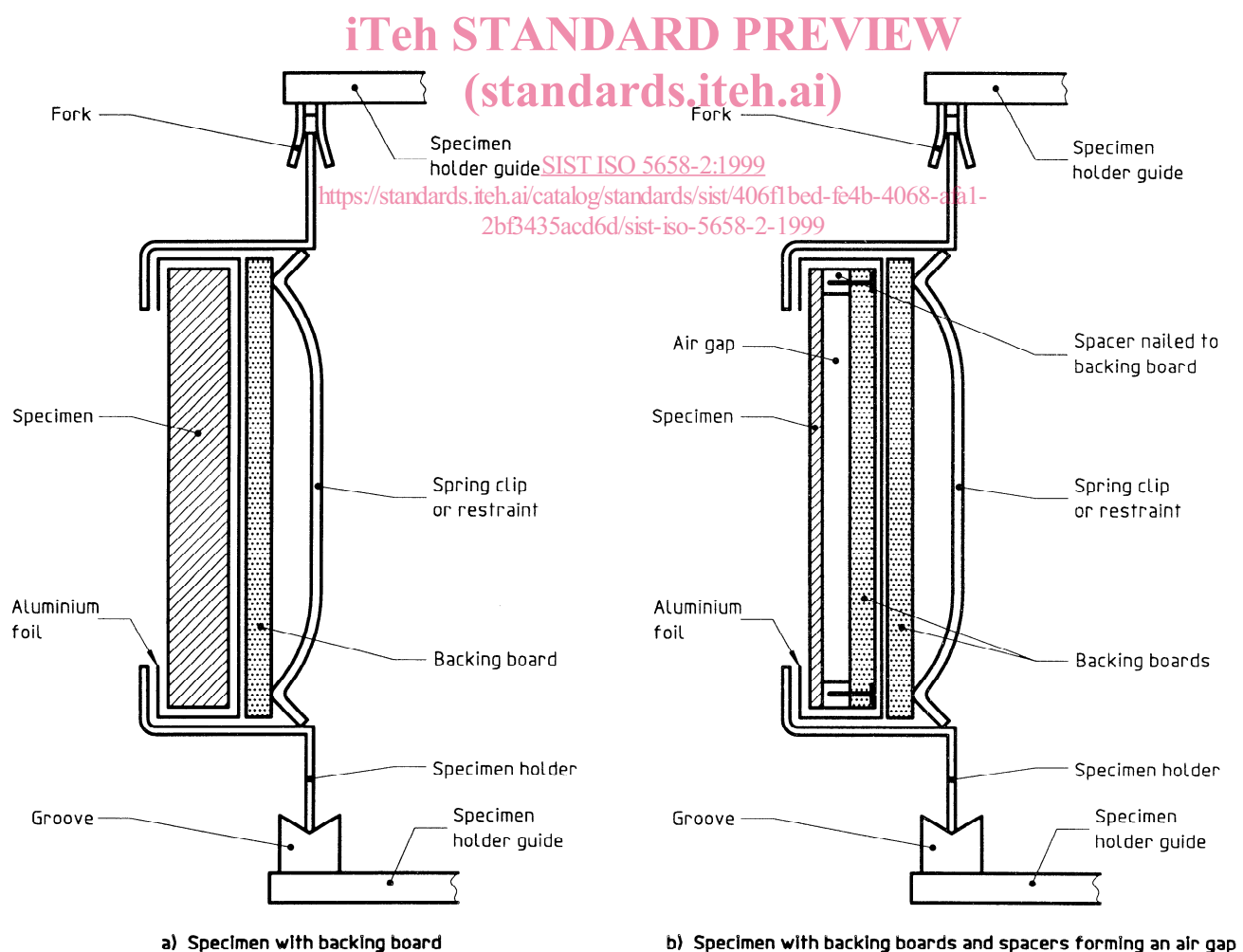

**Figure 2 — Typical mounting of specimens**

**6.3.2** When the product is a surface coating it shall be applied to the selected substrate using a method and application rate recommended for its use.

**6.3.3** When the product is a material or composite which would normally be attached to a substrate, then it shall be tested in conjunction with the selected substrate using the recommended fixing technique, e.g. bonded with the appropriate adhesive or mechanically fixed. The procedure for fixing the specimens to the substrate shall be clearly stated in the test report [see clause 13 f)].

## 6.4 Conditioning

**6.4.1** All specimens shall be conditioned to constant mass at a temperature of  $(23 \pm 2)$  °C, and a relative humidity of  $(50 \pm 5)$  %, and maintained in this condition until required for testing. Constant mass is considered to be attained when two successive weighing operations, carried out at an interval of 24 h, do not differ by more than 0,1 % of the mass of the specimen, or 0,1 g, whichever is the greater.

**6.4.2** Backing boards and spacers (see 9.7) shall be conditioned for at least 12 h before use in the conditions specified in 6.4.1.

## 6.5 Preparation

### 6.5.1 Reference line

Mark a horizontal line centrally at half height along the length of each specimen. Draw vertical marks every 50 mm along the line. The zero mark shall correspond with the start of the exposed area of the specimen (see 7.4). Care shall be taken to avoid the possibility of the line influencing the performance of the specimen, for example by damaging the surface, or increasing its absorbency.

NOTE 4 Some materials discolour or burn so that the line and/or the marks are obscured. The use of a stainless steel grid approximately 10 mm above the surface of the specimen allows the position of the flame front to be determined.

### 6.5.2 Products without air gaps

Where a product will normally be used without an air gap behind it, then after the conditioning procedures specified in 6.4, the edges and the rear face of the specimen shall be wrapped in a single rectangular sheet of aluminium foil of thickness 0,02 mm to 0,03 mm and dimensions of  $(175 + 2a)$  mm by

$(820 + 2a)$  mm, where  $a$  is the thickness of the specimen, so that about 10 mm of foil laps evenly over the edges of the front face of the specimen. The foil shall be pressed down flat onto the front face of the specimen [see figure 2 a)]. The specimen, wrapped in foil, shall then be placed on a backing board and both inserted in a specimen holder (see figure 3).

### 6.5.3 Products with air gaps

Where a product will normally be used with an air gap behind it, then after the conditioning procedures specified in 6.4, the specimen shall be placed over conditioned spacers positioned around its perimeter [see figure 2 b)] and mounted on a backing board so that a  $(25 \pm 2)$  mm air gap is provided between the unexposed face of the specimen and the backing board (see 9.7). The rear edges of the whole assembly shall then be wrapped in a single rectangular sheet of aluminium foil of thickness 0,02 mm to 0,03 mm and dimensions of  $(175 + 2b)$  mm by  $(820 + 2b)$  mm, where  $b$  is the total thickness of the assembly of specimen, spacers and backing board, so that about 10 mm of foil laps evenly over the edges of the front face of the specimen. The foil shall be pressed down flat onto the front face of the specimen [see figure 2 b)]. The assembly, wrapped in foil, shall then be placed on a backing board and both inserted in a specimen holder (see figure 3).

Products containing air gaps of less than 25 mm should preferably be tested under their end use conditions.

A suitable technique for mounting thin flexible materials is to staple closely the specimen along the edges to the spacers on the perimeter of the backing board.

### 6.5.4 Storage of specimens

The wrapped assemblies of specimen, backing board and spacers prepared as specified in 6.5.2 or 6.5.3 shall be stored until required for testing in the conditioning atmosphere specified in 6.4.1.

## 7 Test apparatus

### 7.1 General

The test apparatus (see figure 4) consists of four main components: a radiant panel support framework and a specimen support framework, which are linked together to bring the test specimen into the required configuration in relation to the radiant panel, the specimen holder, and a pilot flame burner.

### 7.2 The radiant panel support framework

This framework provides the support for the radiant panel together with the necessary pipework for air and gas, safety devices, regulators and flowmeters.