



Designation: ~~D6804~~—19 D6804 – 24

Standard Guide for Hand Hole Design in Corrugated Boxes¹

This standard is issued under the fixed designation D6804; the number immediately following the designation indicates the year of original adoption or, in the case of revision, the year of last revision. A number in parentheses indicates the year of last reapproval. A superscript epsilon (ϵ) indicates an editorial change since the last revision or reapproval.

1. ~~Scope~~ Scope*

1.1 This standard provides guidelines for designing pre-cut apertures intended for use as hand holes in corrugated boxes during manual handling of boxed cargo.

1.2 *Limitations*—This standard offers guidance for package development and for subsequent testing of boxes to measure performance. It is not intended to provide specific information on the design of hand holes.

1.3 The values stated in inch-pound units are to be regarded as the standard. The SI units are for information only.

1.4 *This standard does not purport to address all of the safety concerns, if any, associated with its use. It is the responsibility of the user of this standard to establish appropriate safety, health, and environmental practices and determine the applicability of regulatory limitations prior to use.*

1.5 *This international standard was developed in accordance with internationally recognized principles on standardization established in the Decision on Principles for the Development of International Standards, Guides and Recommendations issued by the World Trade Organization Technical Barriers to Trade (TBT) Committee.*

2. Referenced Documents

[ASTM D6804-24](https://standards.iteh.ai/catalog/standards/astm/0ea95ca4-5b37-4eb1-9742-05cd51f8977a/astm-d6804-24)

<https://standards.iteh.ai/catalog/standards/astm/0ea95ca4-5b37-4eb1-9742-05cd51f8977a/astm-d6804-24>

2.1 *ASTM Standards*:²

[D996 Terminology of Packaging and Distribution Environments](#)

[D1974 Practice for Methods of Closing, Sealing, and Reinforcing Fiberboard Boxes](#)

[D4332 Practice for Conditioning Containers, Packages, or Packaging Components for Testing](#)

[D5276 Test Method for Drop Test of Loaded Containers by Free Fall](#)

[D5445 Practice for Pictorial Markings for Handling of Goods](#)

[E4 Practices for Force Calibration and Verification of Testing Machines](#)

[E122 Practice for Calculating Sample Size to Estimate, With Specified Precision, the Average for a Characteristic of a Lot or Process](#)

2.2 *TAPPI Standards*:³

[T400 Sampling and Accepting a Single lot of Paper, Paperboard, Containerboard, or Related Product](#)

¹ This guide is under the jurisdiction of ASTM Committee D10 on Packaging and is the direct responsibility of Subcommittee D10.27 on Fiberboard Shipping Containers, Containerboard and Related Structures and Materials.

Current edition approved Oct. 1, 2019/March 1, 2024. Published November 2019/March 2024. Originally approved in 2002. Last previous edition approved in 2015/2019 as D6804–02(2015). DOI: 10.1520/D6804-19–19. DOI: 10.1520/D6804-24.

² For referenced ASTM standards, visit the ASTM website, www.astm.org, or contact ASTM Customer Service at service@astm.org. For *Annual Book of ASTM Standards* volume information, refer to the standard's Document Summary page on the ASTM website.

³ Available from Technological Association of the Pulp and Paper Industry (TAPPI), 15 Technology Parkway South, Suite 115, Peachtree Corners, GA 30092, http://www.tappi.org.

*A Summary of Changes section appears at the end of this standard

3. Terminology

3.1 *Definitions*—General definitions for packaging and distribution environments are found in Terminology [D996](#).

3.2 *Definitions of Terms Specific to This Standard:*

3.2.1 *hand holes*—apertures, pre-cut in corrugated boxes by box manufacturers, as requested by box purchasers. These apertures facilitate manual handling during distribution and improve grip during handling.

4. Significance and Use

4.1 It may be desirable at times to provide hand holes in corrugated boxes. Package designers use hand holes to solve ergonomic and handling problems associated with large or awkward containers. This guide provides an aid for proper hand hole design and use.

4.1.1 Boxes for handling by a single person.

4.1.2 Boxes that are too large or awkward to be handled well by a single person ([4.4.1](#)).

4.2 *Ergonomics:*

4.2.1 In studying and applying ergonomic principles, of primary concern is the need to provide a safe work environment for material handlers who may be required to lift or transport packages. A safe work environment is difficult to define and varies with the package in question. Several ergonomic safety issues involve repetitive motions and spine loading in the lifting process. Other issues involve finger and foot protection.

4.2.2 In distribution centers or warehouses, low back disorders have been identified as areas of elevated risk. Low back problems continue to represent the most common and costly musculoskeletal disorders in the work place.⁴

4.2.3 One method used to reduce the concern of distance of lift (spinal loading) is to bring the reach of the material handler's hands closer to the body. With large or awkward boxes, placing hand holes in a more advantageous position can solve this problem.

4.2.4 Maximum weight for lifting is not generally specified by safety organizations. However, when considerations of repetition, movement, and other ergonomics are taken into account, a typical maximum load per single person is often limited to 40 to 50 lb per package.

4.3 *NIOSH:*

4.3.1 The National Institute for Occupational Safety and Health (NIOSH) has published *Work Practices Guide for Manual Lifting*.⁵ This document may be of assistance in developing proper hand holes and their placement for a specific package.

4.3.2 Hand holes for single person box handling are generally intended for vertical symmetric lifting with some rotation and is limited to a few steps. Use of hand holes to lift with one hand, push a box, or pull a box are not recommended practices.

4.3.2.1 Pushing or pulling by hand holes can weaken the box sidewall and thus reduce compression resistance at the time of damage and reduce the expected time a box can survive constant load before failure (lifetime).

4.3.2.2 Pulling by hand holes may lead to tearing and loss of control of box as it exits its supporting structure ([Appendix X1](#)).

4.3.3 Actual maximum acceptable load for a single person lift depends on box weight, size, lift frequency and distance of movement. Maximum weight and size limits can be estimated using the NIOSH equations.

4.4 *Other Box Apertures – Improper Use as Hand Holes:*

⁴ "Effects of Box Features on Spine Loading during Warehouse Order Selecting," Marras, Granata, Davis, Allread, and Jorgensen, The Institute for Ergonomics, Ohio State University.

⁵ NIOSH Technical Report No. 81-122 from the US Department of Health and Human Services.

4.4.1 Some hand holes are intended for hand gripping to facilitate moving or turning a heavy box but are not intended for lifting.

4.4.2 Not all box apertures are intended to be used as hand holes. These apertures may be intended for ventilation, inspection, adjustment of contents or other uses. These other apertures are not intended for use in manipulating boxes and it is improper to use these apertures as hand holes.

4.4.3 Examples of typical hand holes are shown in Fig. 1. Use of hand holes and associated cautions should be agreed upon between the supplier and the user.

4.4.4 Since all end use conditions and requirements cannot be foreseen and since designing for worst case scenario for all applications is prohibitively expensive, designers should follow best practices. The prudent designer will consider product and package weight when deciding the proper use of a hand hole.

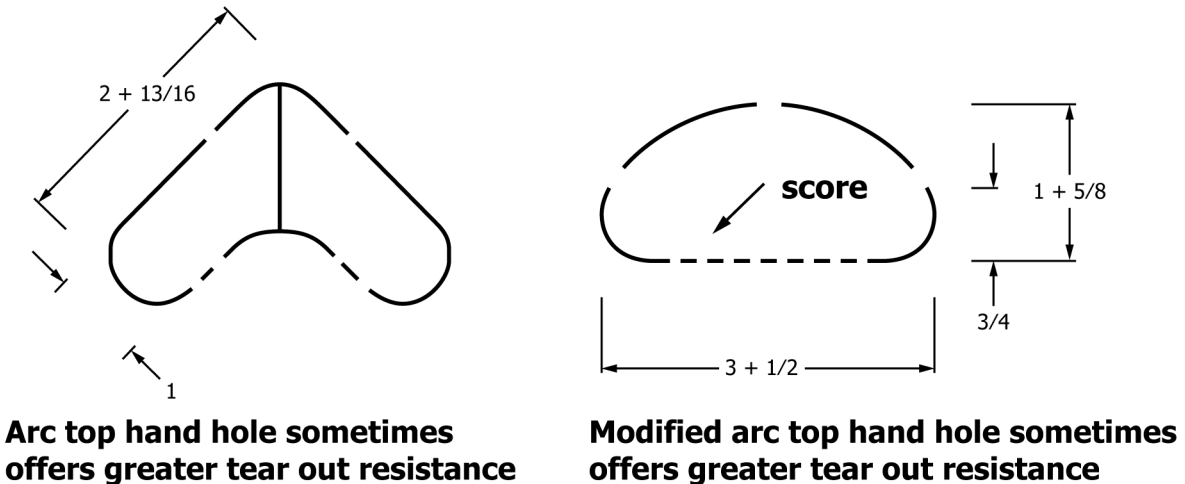
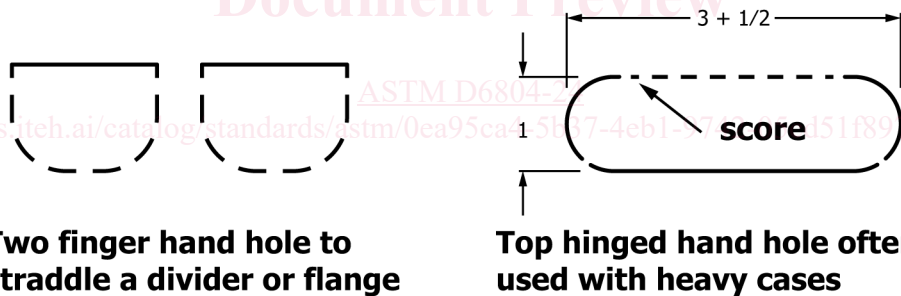
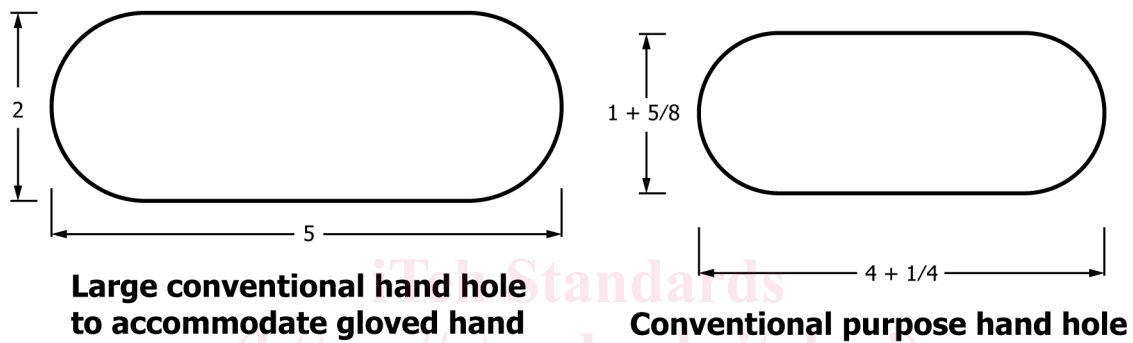

FIG. 1 Common Hand Hole Types

5. General Design Considerations

5.1 Hand holes can take many forms (see Fig. 1). They can:

- 5.1.1 Be a simple hole in a box,
- 5.1.2 Be a complex molded handle with a reinforcement mounted at the attaching point,
- 5.1.3 Incorporate rope handles, and
- 5.1.4 Be reinforced by the box maker with reinforcing tape applied above them.

5.2 If possible, position hand holes so that product and internal cushioning material can add support for carrying (see Fig. 2). If the box must bear all the weight, it is best to position the hand holes at least 2 in. below the horizontal score line of end panels to distribute the compressive forces and avoid failure. When placing hand holes, consider product balance and box closure method.

5.3 Some closure methods, such as taping, can affect hand hole placement. When a hand hole is to be used with a box style such as an RSC, which is to have a tape closure (see Practice D1974), it is best to allow enough room (2 to 2½-in.) for the end-leg of the tape (see Fig. 3). For a Bliss style box, hand holes should be placed just below the top flange (see Fig. 4).

5.4 Several methods are used to reinforce a box above the hand hole. For example, pressure sensitive, heat activated, and adhesive based products can be used. Some have fiberglass or polyester yarn reinforcement, some are tensilized, and some are made of heavy kraft paper (see Fig. 5).

5.5 When possible, use curved type hand holes: they will not tear as easily as the straight top design (see Fig. 4). The curved design eliminates a sharp edge at the corners, resulting in a more evenly distributed lifting force across the surface. Note that a different type of grasping device will be required when testing curved hand holes as opposed to straight ones (see XI.3, Apparatus).

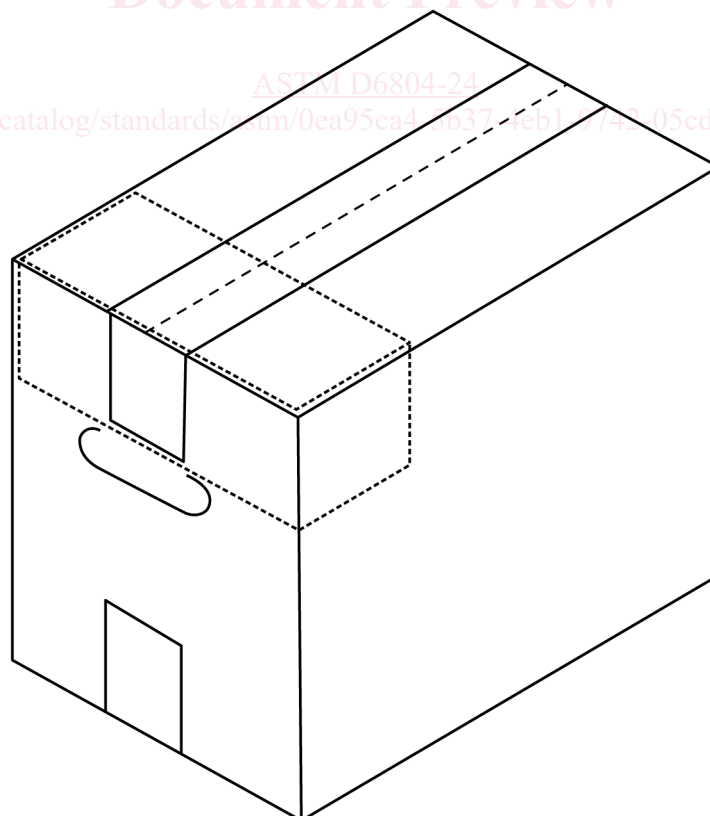

FIG. 2 Box with Internal Cushioning Material, Showing Location above Hand Hole to Provide Added Support for Carrying

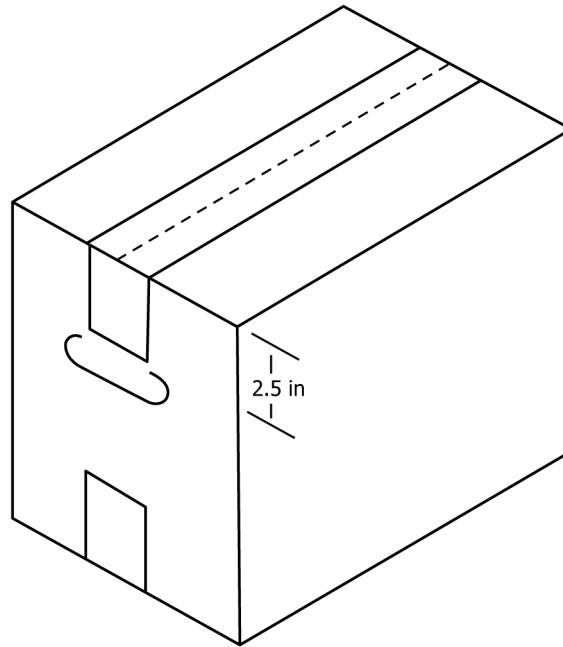

FIG. 3 RSC Style Box with Tape Closure, Showing Location of Hand Hole 2.5 in. below Top Edge of Box

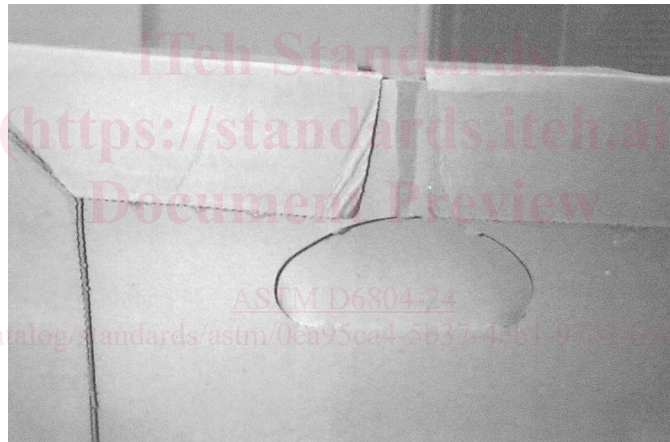

FIG. 4 Bliss Style Box Showing Curved Hand Hole Located just below the Top Flange

5.6 Singlewall boxes with hand holes may require hole reinforcement or double scoring as the board alone may not have sufficient strength to prevent tearing. Moderate to heavy weight boxes (4.2.4) with hand holes are often made with double wall board. Very heavy boxes may require the use of triple wall board which often utilizes mechanical handling. Hand holes in triple wall board are commonly for purposes other than vertical lifting.

5.7 ECT board is designed for stacking strength. Mullen board is designed for rough handling. Use of hand holes in ECT board will reduce compression strength. Use of hand holes in Mullen board will reduce durability. These strength reductions should be considered when designing boxes with hand holes. Mullen board compared to ECT board for similar uses has generally better tear resistance which could affect hand hole strength.

6. Labels , Symbols, and Cautions

6.1 Labels, printed symbols, or cautions can be used to clarify appropriate and inappropriate use of hand holes.

6.1.1 Safety labels that can be used to caution, warn, or require lifting by two or more people can be obtained from many sources on the internet.

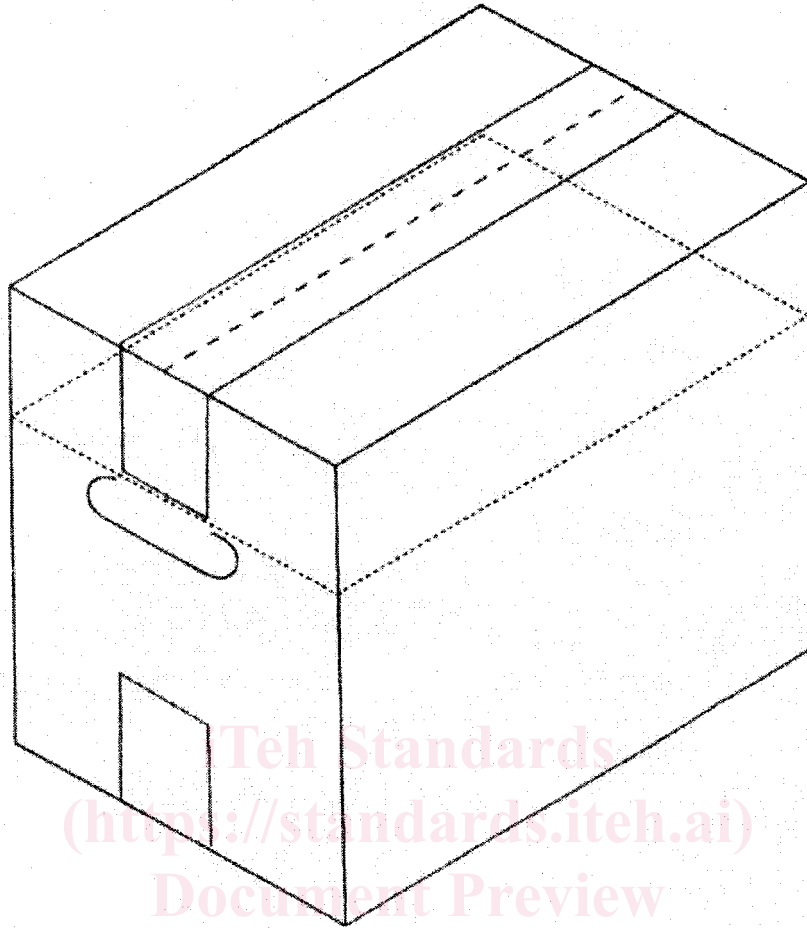

FIG. 5 RSC Style Box Showing Placement of Reinforcement Material around Perimeter of Box, just above Hand Hole

[ASTM D6804-24](https://standards.itih.ai/catalog/standards/astm/0ea95ca4-5b37-4eb1-9742-05cd51f8977a/astm-d6804-24)

<https://standards.itih.ai/catalog/standards/astm/0ea95ca4-5b37-4eb1-9742-05cd51f8977a/astm-d6804-24>

6.1.2 Practice **D5445** contains a number of safety symbols that are intended to improve safe handling of boxes.

6.1.3 Additional cautions or warnings for boxes intended to be manipulated by hand holes are shown in **Fig. 6**.

7. Evaluation

7.1 The test methods in **Appendix X1** are not ASTM standards, but are evaluation methods to assist in determining the relative performance of hand holes during handling in the distribution environment. The methods, in experimental trials, were shown to have high variability between laboratories; however, within laboratories the methods were useful in determining relative performance.

8. Keywords

8.1 corrugated boxes; distribution environment; hand holes; manual handling; symbols

Use Both Hands to Lift Box
Do Not Pull Box Using Hand Hole

FIG. 6 Additional Cautions or Warnings for Boxes Intended to be Manipulated by Hand Holes