



Designation: ~~D8336–21~~ D8336 – 24

Standard Test Method for Characterizing Tack of Prepregs Using a Continuous Application-and-Peel Procedure¹

This standard is issued under the fixed designation D8336; the number immediately following the designation indicates the year of original adoption or, in the case of revision, the year of last revision. A number in parentheses indicates the year of last reappraisal. A superscript epsilon (ϵ) indicates an editorial change since the last revision or reappraisal.

1. Scope

1.1 This test method covers measurement of adhesion (tack) between partially cured (B-staged) composite prepreg and a substrate surface in a peel test, under specified conditions. The test may be conducted to measure tack between a flexible layer of prepreg and another prepreg layer bonded to a rigid substrate (Method I) or a rigid metal substrate (Method II). This test method is primarily geared towards material characterization for automated material layup but can be modified for use with other processes. It is well known that material tack is a function of multiple processing and environmental variables. Permissible composite prepreg materials include carbon, glass, and aramid fibers within a B-staged thermoset resin.

1.2 Measured tack is specified in terms of a peel force at a given specimen width.

1.3 *Units*—The values stated in SI units are to be regarded as standard. The values given in parentheses after SI units are provided for information only and are not considered standard. The values stated in each system are not necessarily exact equivalents; therefore, to ensure conformance with the standard, each system shall be used independently of the other, and values from the two systems shall not be combined.

1.4 *This standard does not purport to address all of the safety concerns, if any, associated with its use. It is the responsibility of the user of this standard to establish appropriate safety, health, and environmental practices and determine the applicability of regulatory limitations prior to use.*

1.5 *This international standard was developed in accordance with internationally recognized principles on standardization established in the Decision on Principles for the Development of International Standards, Guides and Recommendations issued by the World Trade Organization Technical Barriers to Trade (TBT) Committee.*

2. Referenced Documents

2.1 ASTM Standards:²

- [A480/A480M Specification for General Requirements for Flat-Rolled Stainless and Heat-Resisting Steel Plate, Sheet, and Strip](#)
- [D883 Terminology Relating to Plastics](#)
- [D1781 Test Method for Climbing Drum Peel for Adhesives](#)
- [D3167 Test Method for Floating Roller Peel Resistance of Adhesives](#)
- [D3330 Test Method for Peel Adhesion of Pressure-Sensitive Tape](#)
- [D3878 Terminology for Composite Materials](#)

¹ This test method is under the jurisdiction of ASTM Committee D30 on Composite Materials and is the direct responsibility of Subcommittee D30.03 on Constituent/Precursor Properties.

Current edition approved Feb. 1, 2024/ Feb. 15, 2024. Published March 2024/ March 2024. Originally approved in 2021. Last previous edition approved in 2021 as D8336 – 21. DOI: ~~10.1520/D8336-21~~ 10.1520/D8336-24.

² For referenced ASTM standards, visit the ASTM website, www.astm.org, or contact ASTM Customer Service at service@astm.org. For *Annual Book of ASTM Standards* volume information, refer to the standard's Document Summary page on the ASTM website.

- [D6862 Test Method for 90 Degree Peel Resistance of Adhesives](#)
- [E4 Practices for Force Calibration and Verification of Testing Machines](#)
- [E122 Practice for Calculating Sample Size to Estimate, With Specified Precision, the Average for a Characteristic of a Lot or Process](#)
- [E177 Practice for Use of the Terms Precision and Bias in ASTM Test Methods](#)
- [E456 Terminology Relating to Quality and Statistics](#)
- [E691 Practice for Conducting an Interlaboratory Study to Determine the Precision of a Test Method](#)

3. Terminology

3.1 *Definitions*—Terminology [D3878](#) defines terms relating to composite materials. Terminology [D883](#) defines terms relating to plastics. Terminology [E456](#) and Practice [E177](#) define terms relating to statistics. In the event of a conflict between terms, Terminology [D3878](#) shall have precedence over the other documents.

4. Summary of Test Method

4.1 A continuous application-and-peel method is employed to quantify tack at given test conditions (such as temperature) between one B-staged prepreg layer and the surface of a second B-staged prepreg layer which is bonded to a rigid substrate, substrate (Method I), or between a B-staged prepreg specimen and a rigid substrate layer and the surface of a rigid substrate (Method II). During a test, a prepreg specimen laid up on a substrate with or without another prepreg layer is fed through the test fixture continuously (see Fig. 1). The compaction roller presses the prepreg against the substrate surface (and against the peel roller) at a controllable force, bonding the prepreg to the substrate surface at a set application rate. Simultaneously, the prepreg is peeled from the substrate surface at a peel rate which is identical to the application rate. Data is collected over two phases where only the second phase is related to adhesion. The peel force is determined from the difference in the average force between the two phases. Measuring the peel force during a test gives a measure for the strength of adhesion between prepreg and substrate at the given peel rate.

5. Significance and Use

5.1 Characterizing tack for different prepreg materials, test parameters, surface combinations, and environmental conditions provides insight for optimizing process parameters (particularly deposition rate and deposition temperature) for industrial automated material placement processes.

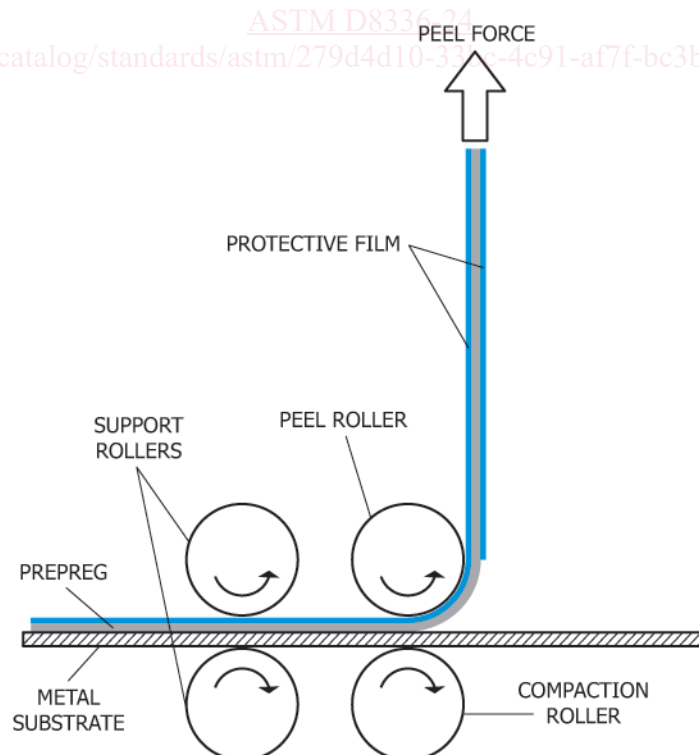

FIG. 1 Schematic of Continuous Application-and-Peel Test Method (Example: Method II)

5.2 Results obtained through employing the continuous application-and-peel method, as described in studies (1-3),³ reflect the effects of adhesion forming between prepreg layers or between prepreg and metal substrate, and loss of cohesion within the resin in the prepreg, upon tack. This test method allows the adhesive properties of B-staged resin to be explored in a manner relevant for dynamic material deposition processes, where timescales for bonding of prepreg to the substrate or previously placed prepreg layers are short prior to curing. In contrast, Test Methods D3167 and D1781 determine the peel resistance of adhesive bonds for adhesion measurement and process control of laminated or bonded adherends.

5.3 The test method is suitable to quantify tack of prepregs for acceptance and process control and can be extended to determine resin shelf life or to adjust process parameters to resin out-time. Direct comparison of different resins/prepregresins/prepregs or processes can only be made when specimen preparation and test conditions are identical.

6. Interferences

6.1 *Material Test Face*—The manufacturing of prepregs may cause differences in resin content and resin distribution between the two sides or faces of the prepreg, which may have an effect on tack. Hence, tack tests must be carried out consistently on the same prepreg face to minimize interference due to the possible difference in material properties on the prepreg surfaces. It is recommended that the specimen layup assembly should represent the layup relevant to the intended use of the prepreg. For the purpose of this standard, the prepreg faces are defined in Fig. 2.

6.2 *Material Out-Time*—Prepreg out-time from frozen storage can change the characteristics of the material. Follow the guidelines provided by the material manufacturer for material storage and out-life. The operator must record and report changes to material out-time where applicable, in line with 13.1.

6.3 *Rigid Substrate Test Surface*—For tests following Method II, contaminants on the metal substrate surfaces can affect prepreg tack. Ensure that the surfaces are clean and dry as specified in 11.3, prior to application of the prepreg.

6.4 *Environmental Control and Measurement*—Variation in test temperature will affect tack; the recommendations for temperature control in the environmental chamber are specified in 7.1.11. Relative humidity has also been shown to affect prepreg tack (2). Unless specific conditioning of the prepreg is required (see Section 10), the relative humidity during the test shall be recorded as specified in 11.4.4 for each test temperature.

7. Apparatus

7.1 The test fixture (Fig. 23) holds two pairs of stiff rollers, arranged horizontally. One pair of rollers supports the specimen during a test. In the second pair, the top roller (peel roller) is fixed in position, while springs apply a vertical force on the bottom roller (compaction roller), allowing it to press the prepreg onto the substrate surface. All components of the fixture shall be of sufficient stiffness not to deform during a test. The fixture is mounted on the base of a test machine.

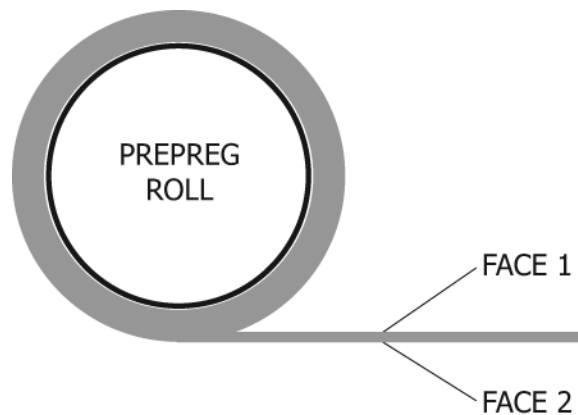

FIG. 2 Identification of Prepreg Surfaces When Unrolling From the Prepreg Roll

³ The boldface numbers in parentheses refer to the list of references at the end of this standard.

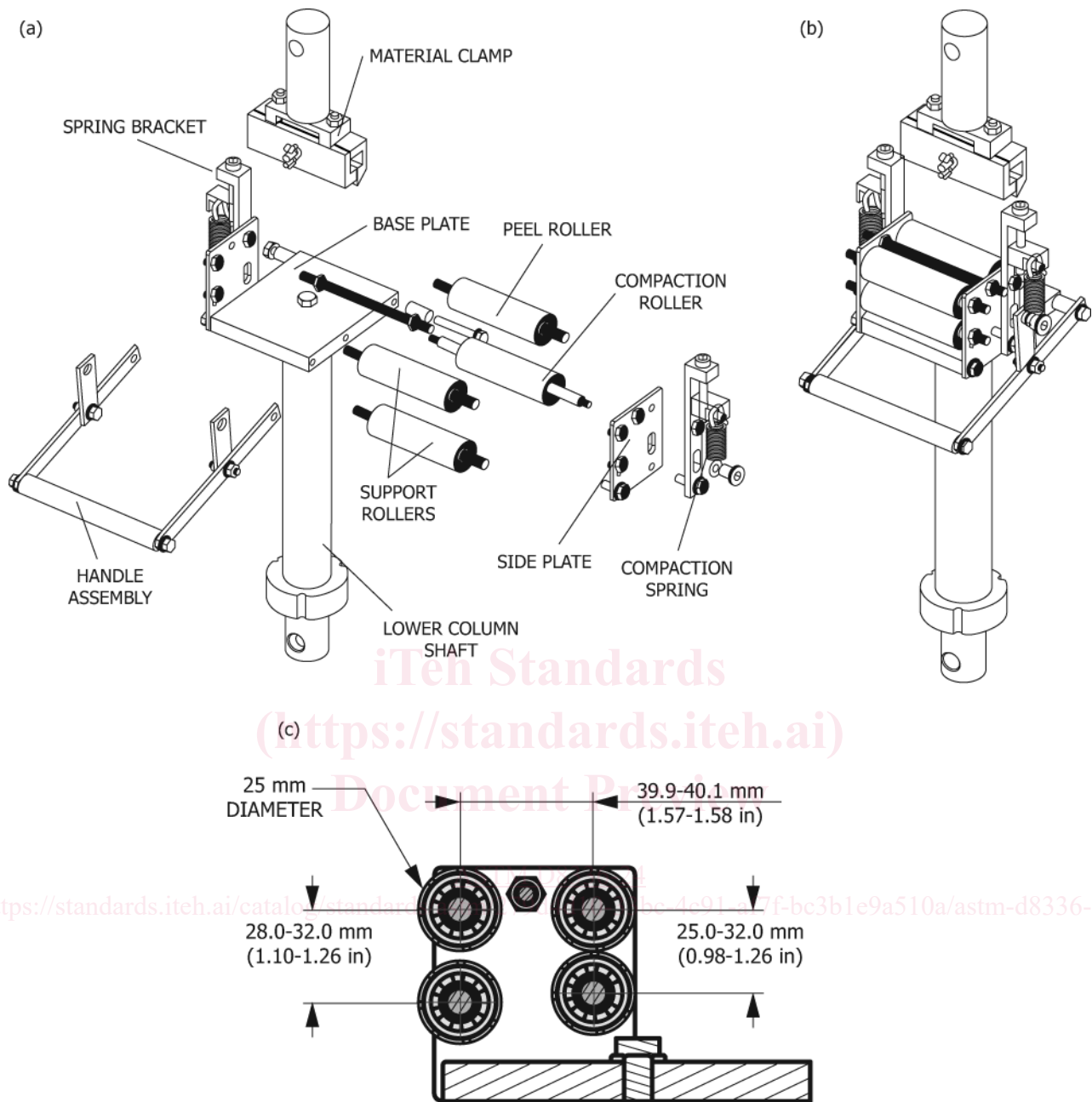

FIG. 23 Tack Testing Fixture: (a) Exploded View of Assembly, (b) Fully Assembled, and (c) Initial Rollers Positions Prior to a Test Whereby the Vertical Distance Indicates the Travel Range Between the Two Rollers to Accommodate Various Thicknesses of Prepreg and Substrate

7.1.1 The base plate shall be wide enough to accommodate the rollers.

7.1.2 The side plates shall be attached to the base plate. The side plates shall have holes for the peel roller axle and the top support roller axle, slots (vertical) for the compaction roller axle, as well as slots for the bottom support roller axle (which can be adjusted to ensure sufficient clearance between the support rollers to accommodate specimens of different thickness).

7.1.3 The lower column shaft shall fit the base of the testing machine. Its dimensions shall position the peel roller directly below the moving cross-head (Fig. 23(b)) to allow the prepreg to be peeled from the substrate surface at an angle of 90°. Positioning is critical to ensure clearance between all parts of the set-up during a test. For tests conducted in non-ambient environments, the lower column shaft shall position the fixture in the center of the environmental chamber.

7.1.4 The peel roller shall be in a fixed position as determined by holes in the side plates. The roller surface shall be stiff and not deform when a compaction load is applied. Rotary bearings shall be used to minimize frictional losses in the roller. The recommended roller width is 80 mm (3.15 in.), and the recommended diameter is 25 mm (0.98 in.), although other dimensions may be utilized.

7.1.5 The compaction roller shall have the same design as the peel roller. It is suspended on springs and can move within the vertical slots in the side plates.

7.1.6 The support rollers shall have the same design as the peel roller. The bottom support roller shall be positioned at the same height as the compaction roller (adjustable height). The recommended horizontal distance from the compaction roller is 40 mm (1.57 in.).

7.1.7 The compaction springs shall be sufficiently robust to withstand overloading. Their behavior shall be linear around the target compaction load.

7.1.8 The spring brackets shall be attached to the side plates. They shall be long enough to allow appropriate loading (extension or relaxation) of the compaction springs through adjusting jacking screws

7.1.9 The material clamp shall fit the connector at the load cell of the testing machine. It shall be wider than the specimens but fit in the gap between the spring brackets. Clamping of the flexible prepreg layer prevents slip during a test and holds the layer against the face of the peel roller. When connected to the load cell, the material clamp shall be aligned with the peel roller axis (Fig. 3(b)), such that twisting of the prepreg layer is avoided when a specimen/substrate layup is inserted into the test fixture and one end of the specimen is clamped.

7.1.10 A handle assembly is connected to a lever mechanism which allows opening a gap between the compaction and peel rollers for loading of a substrate with a specimen.

7.1.11 An environmental test chamber is required for test environments other than ambient testing laboratory conditions. This chamber shall be capable of maintaining the test specimen at the required test environment during the mechanical test.

8. Sampling and Test Specimens

8.1 *Sampling*—Test at least five specimens per test condition unless valid results can be gained through the use of fewer specimens, as in the case of a designed experiment. For statistically significant data, the procedures outlined in Practice E122 should be consulted. For specimens obtained from a prepreg roll, it is recommended that prepreg surfaces are identified as Face 1 and Face 2 when unrolled from the prepreg roll as shown in Fig. 32 to aid sample preparation. The method of sampling shall be reported in accordance with 13.1.

8.2 Geometry:

8.2.1 Specimens shall be cut from a tape or sheet of prepreg. If a uni-directional prepreg tape is to be tested, the fiber orientation in the test specimen must be parallel to the long axis of the substrate. If a prepreg with bi-directional reinforcement is tested, one of the fiber directions needs to be parallel with the long axis of the substrate. Specimen length shall be at least 215 mm (8.46 in.), and the recommended specimen width shall be 75 mm (2.95 in.). If a different specimen width is used, it must be ensured that the specimen width is narrower than both the rollers and the substrate. The specimen width shall be recorded as specified in 13.1.9. The specimen surface whose tack is not being evaluated shall be covered with the protective film normally provided with a prepreg roll. The purpose of the film is to prevent resin from the prepreg to transfer to the fixture rollers. A suitably flexible film that will not wrinkle when wrapped around the roller can be used for this purpose. Fig. 4 illustrates the specimen layup assemblies for Methods I and II consisting of the prepreg specimen, protective films, and rigid substrate.

8.2.2 Rigid substrates are recommended to be made from stainless steel with Specification A480/A480M No. 2B finish. If other suitably rigid substrate materials are used, with a surface finish allowing the substrate to pass smoothly over the compaction roller, this must be recorded as specified in 13.1.8. The substrate shall be at least 140 mm (5.51 in.) in length, 80 mm (3.15 in.) in width, and 0.8 mm (0.03 in.) thick. The edges of the substrates shall be deburred if cut from a larger sheet.

8.3 If tack between two layers of prepreg is to be tested (Method I), an additional layer of prepreg shall be cut from a tape or sheet. This layer does not need to be the same type of prepreg as the layer to be peeled (described in 8.2.1), but the specimen layup

a) SIDE VIEW

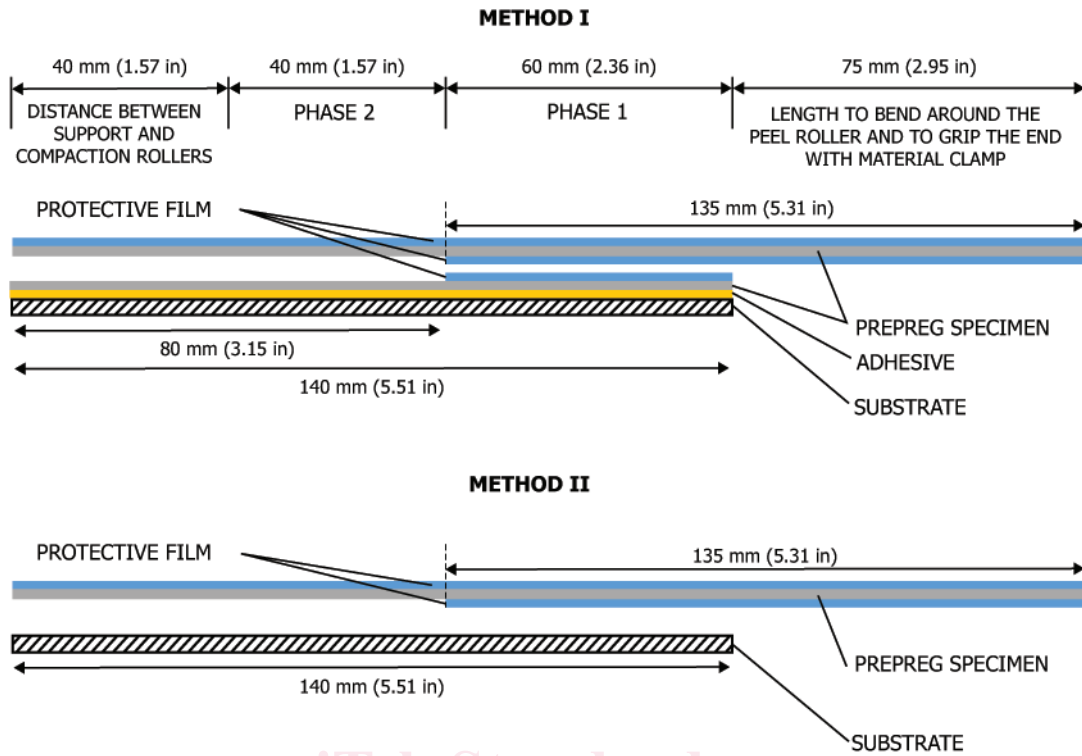

b) TOP VIEW (FOR BOTH METHODS I & II)

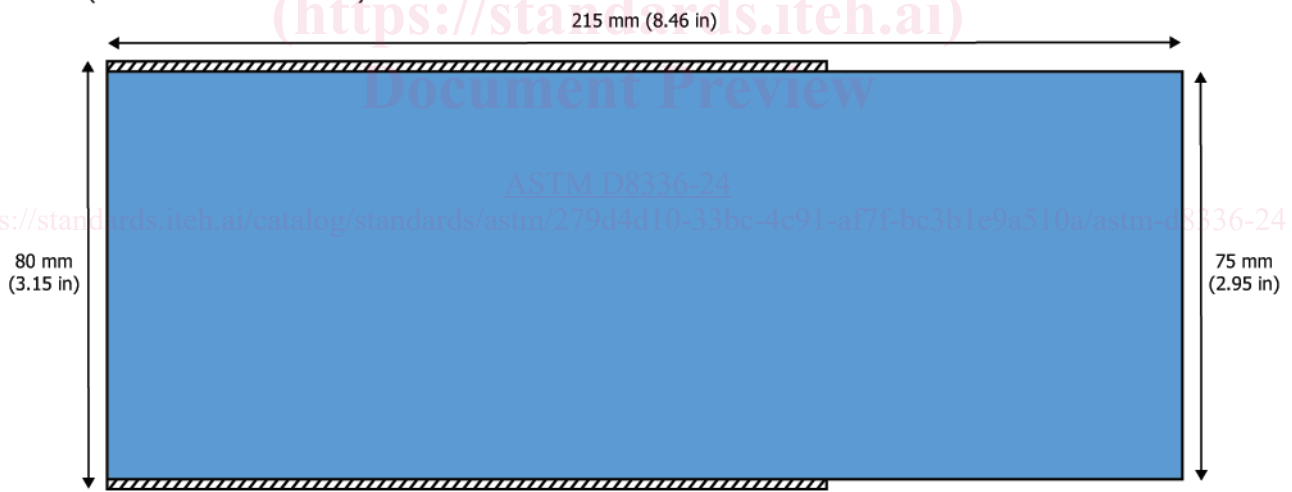

FIG. 4 Specimen Assembly for Both Methods I and II: (a) Side View and (b) Top View

assembly should represent the layup relevant to the intended use of the prepreg. The orientation of this prepreg layer does not need to be parallel with the long axis of the substrate. The angle between the fiber orientation in uni-directional prepreg tapes and the substrate axis (that is, peel direction) or the angle between the fabric warp-direction in prepreg fabrics and the substrate axis can be set as in the production layup. The length of this layer shall correspond to the length of the substrate; the width is the same as for the other specimen layer within a tolerance specified during slitting of the material, in the absence of which a general tolerance of ± 1 mm shall be used. One A 60 mm length of the upper surface of the additional layer of prepreg congruent with the covered part of the upper prepreg layer (Phase I) shall be covered with protective film. as shown in Fig. 4(a).

NOTE 1—Within the recommendations stated in 8.2, other dimensions of specimen and of rigid substrate may be used, provided that the environmental chamber and tack test fixture can accommodate the specimen dimensions for the application-and-peel motion.