



Designation: D8048 – 24

Standard Test Method for Evaluation of Diesel Engine Oils in T-13 Diesel Engine¹

This standard is issued under the fixed designation D8048; the number immediately following the designation indicates the year of original adoption or, in the case of revision, the year of last revision. A number in parentheses indicates the year of last reapproval. A superscript epsilon (ϵ) indicates an editorial change since the last revision or reapproval.

INTRODUCTION

This test method is written for use by laboratories that use the portions of the test method that refer to ASTM Test Monitoring Center (TMC)² services (see [Annex A1 – Annex A4](#)).

The TMC provides reference oils, and engineering and statistical services to laboratories that desire to produce test results that are statistically similar to those produced by laboratories previously calibrated by the TMC.

In general, the Test Purchaser decides if a calibrated test stand is to be used. Organizations such as the American Chemistry Council require that a laboratory utilize the TMC services as part of their test registration process. In addition, the American Petroleum Institute and the Gear Lubricant Review Committee of the Lubricant Review Institute (SAE International) require that a laboratory use the TMC services in seeking qualification of oils against their specifications.

The advantage of using the TMC services to calibrate test stands is that the test laboratory (and hence the Test Purchaser) has an assurance that the test stand was operating at the proper level of test severity. It should also be borne in mind that results obtained in a non-calibrated test stand may not be the same as those obtained in a test stand participating in the ASTM TMC services process.

Laboratories that choose not to use the TMC services may simply disregard these portions.

ASTM International policy is to encourage the development of test procedures based on generic equipment. It is recognized that there are occasions where critical/sole-source equipment has been approved by the technical committee (surveillance panel/task force) and is required by the test procedure. The technical committee that oversees the test procedure is encouraged to clearly identify if the part is considered critical in the test procedure. If a part is deemed to be critical, ASTM encourages alternative suppliers to be given the opportunity for consideration of supplying the critical part/component providing they meet the approval process set forth by the technical committee.

An alternative supplier can start the process by initiating contact with the technical committee (current chairs shown on ASTM TMC website). The supplier should advise on the details of the part that is intended to be supplied. The technical committee will review the request and determine feasibility of an alternative supplier for the requested replacement critical part. In the event that a replacement critical part has been identified and proven equivalent the sole-source supplier footnote shall be removed from the test procedure.

1. Scope*

1.1 This test method covers an engine test procedure for evaluating diesel engine oils for oxidation performance characteristics in an engine equipped with exhaust gas recirculation and running on ultra-low sulfur diesel fuel.² This test method is commonly referred to as the Volvo T-13.

1.2 The values stated in SI units are to be regarded as standard. No other units of measurement are included in this standard.

¹ This test method is under the jurisdiction of ASTM Committee D02 on Petroleum Products, Liquid Fuels, and Lubricants and is the direct responsibility of Subcommittee D02.B0 on Automotive Lubricants.

Current edition approved March 1, 2024. Published March 2024. Originally approved in 2016. Last previous edition approved in 2021 as D8048 – 21a^{ε1}. DOI: 10.1520/D8048-24.

² The ASTM Test Monitoring Center will update changes in this test method by means of Information Letters. Information letters may be obtained from the ASTM Test Monitoring Center, 203 Armstrong Drive, Freeport, PA 16229, Attention: Director. This edition incorporates revisions in all Information Letters through No. 23-1.

*A Summary of Changes section appears at the end of this standard

1.2.1 *Exception*—Where there is no direct SI equivalent, such as the units for screw threads, National Pipe Threads/ diameters, tubing size, and single source supply equipment specifications.

1.3 *This standard does not purport to address all of the safety concerns, if any, associated with its use. It is the responsibility of the user of this standard to establish appropriate safety, health, and environmental practices and determine the applicability of regulatory limitations prior to use.* See **Annex A10** for specific safety precautions.

1.4 *This international standard was developed in accordance with internationally recognized principles on standardization established in the Decision on Principles for the Development of International Standards, Guides and Recommendations issued by the World Trade Organization Technical Barriers to Trade (TBT) Committee.*

2. Referenced Documents

2.1 ASTM Standards:³

- D86 Test Method for Distillation of Petroleum Products and Liquid Fuels at Atmospheric Pressure
- D93 Test Methods for Flash Point by Pensky-Martens Closed Cup Tester
- D97 Test Method for Pour Point of Petroleum Products
- D130 Test Method for Corrosiveness to Copper from Petroleum Products by Copper Strip Test
- D235 Specification for Mineral Spirits (Petroleum Spirits) (Hydrocarbon Dry Cleaning Solvent)
- D287 Test Method for API Gravity of Crude Petroleum and Petroleum Products (Hydrometer/Method)
- D445 Test Method for Kinematic Viscosity of Transparent and Opaque Liquids (and Calculation of Dynamic Viscosity)
- D482 Test Method for Ash from Petroleum Products
- D524 Test Method for Ramsbottom Carbon Residue of Petroleum Products
- D613 Test Method for Cetane Number of Diesel Fuel Oil
- D664 Test Method for Acid Number of Petroleum Products by Potentiometric Titration
- D976 Test Method for Calculated Cetane Index of Distillate Fuels
- D1319 Test Method for Hydrocarbon Types in Liquid Petroleum Products by Fluorescent Indicator Adsorption
- D2274 Test Method for Oxidation Stability of Distillate Fuel Oil (Accelerated Method)
- D2500 Test Method for Cloud Point of Petroleum Products and Liquid Fuels
- D2622 Test Method for Sulfur in Petroleum Products by Wavelength Dispersive X-ray Fluorescence Spectrometry
- D2709 Test Method for Water and Sediment in Middle Distillate Fuels by Centrifuge
- D3338 Test Method for Estimation of Net Heat of Combustion of Aviation Fuels

- D3524 Test Method for Diesel Fuel Diluent in Used Diesel Engine Oils by Gas Chromatography
 - D4052 Test Method for Density, Relative Density, and API Gravity of Liquids by Digital Density Meter
 - D4175 Terminology Relating to Petroleum Products, Liquid Fuels, and Lubricants
 - D4294 Test Method for Sulfur in Petroleum and Petroleum Products by Energy Dispersive X-ray Fluorescence Spectrometry
 - D4485 Specification for Performance of Active API Service Category Engine Oils
 - D4739 Test Method for Base Number Determination by Potentiometric Hydrochloric Acid Titration
 - D5185 Test Method for Multielement Determination of Used and Unused Lubricating Oils and Base Oils by Inductively Coupled Plasma Atomic Emission Spectrometry (ICP-AES)
 - D5186 Test Method for Determination of the Aromatic Content and Polynuclear Aromatic Content of Diesel Fuels By Supercritical Fluid Chromatography
 - D5453 Test Method for Determination of Total Sulfur in Light Hydrocarbons, Spark Ignition Engine Fuel, Diesel Engine Fuel, and Engine Oil by Ultraviolet Fluorescence
 - D5967 Test Method for Evaluation of Diesel Engine Oils in T-8 Diesel Engine
 - D6079 Test Method for Evaluating Lubricity of Diesel Fuels by the High-Frequency Reciprocating Rig (HFRR)
 - D7039 Test Method for Sulfur in Gasoline, Diesel Fuel, Jet Fuel, Kerosine, Biodiesel, Biodiesel Blends, and Gasoline-Ethanol Blends by Monochromatic Wavelength Dispersive X-ray Fluorescence Spectrometry
 - E29 Practice for Using Significant Digits in Test Data to Determine Conformance with Specifications
 - E178 Practice for Dealing With Outlying Observations
- 2.2 *National Archives and Records Administration.*⁴
Code of Federal Regulations Title 40 Part 86.310-79

3. Terminology

3.1 Definitions:

- 3.1.1 *blind reference oil, n*—a reference oil, the identity of which is unknown by the test facility.
 - 3.1.1.1 *Discussion*—This is coded reference oil that is submitted by a source independent from the test facility. **D4175**
 - 3.1.2 *blowby, n*—in internal combustion engines, that portion of the combustion products and unburned air/fuel mixture that leaks past piston rings into the engine crankcase during operation.
 - 3.1.3 *calibrate, v*—to determine the indication or output of a device (for example, thermometer, manometer, and engine) with respect to that of a standard.
 - 3.1.4 *candidate oil, n*—an oil that is intended to have the performance characteristics necessary to satisfy a specification and is intended to be tested against that specification. **D4175**

³ For referenced ASTM standards, visit the ASTM website, www.astm.org, or contact ASTM Customer Service at service@astm.org. For *Annual Book of ASTM Standards* volume information, refer to the standard's Document Summary page on the ASTM website.

⁴ Available from U.S. Government Printing Office, Superintendent of Documents, 732 N. Capitol St., NW, Washington, DC 20401-0001, <http://www.access.gpo.gov>.

3.1.5 *exhaust gas recirculation (EGR), n*—the mixing of exhaust gas with intake air to reduce the formation of nitrogen oxides (NO_x). **D4175**

3.1.6 *heavy-duty, adj*—in internal combustion engine operation, characterized by average speeds, power output and internal temperatures that are close to the potential maximums. **D4175**

3.1.7 *heavy-duty engine, n*—in internal combustion engine types, one that is designed to allow operation continuously at or close to its peak output.

3.1.8 *non-reference oil, n*—any oil other than a reference oil; such as a research formulation, commercial oil, or candidate oil. **D4175**

3.1.9 *non-standard test, n*—a test that is not conducted in conformance with the requirements in the standard test method; such as running on an uncalibrated test stand, using different test equipment, applying different equipment assembly procedures, or using modified operating conditions. **D4175**

3.1.10 *oxidation, n*—of engine oil, the reaction of the oil with an electron acceptor, generally oxygen, that can produce deleterious acidic or resinous materials often manifested as sludge formation, varnish formation, viscosity increase, or corrosion, or combination thereof.

3.1.11 *reference oil, n*—an oil of known performance characteristics, used as a basis for comparison.

3.1.11.1 *Discussion*—Reference oils are used to calibrate testing facilities, to compare the performance of other oils, or to evaluate other materials (such as seals) that interact with oils. **D4175**

3.1.12 *sludge, n*—in internal combustion engines, a deposit, principally composed of insoluble resins and oxidation products from fuel combustion and the lubricant that does not drain from engine parts but can be removed by wiping with a cloth. **D4175**

3.1.13 *standard test, n*—a test on a calibrated test stand, using the prescribed equipment in accordance with the requirements in the test method, and conducted in accordance with the specified operating conditions.

3.1.14 *test parameter, n*—a specified component, property, or condition of a test procedure.

3.1.14.1 *Discussion*—Examples of *components* are fuel, lubricant, reagent, cleaner, and sealer; of *properties* are density, temperature, humidity, pressure, and viscosity; and of *conditions* are flow rate, time, speed, volume, length, and power. **D4175**

3.1.15 *varnish, n*—in internal combustion engines, a hard, dry, generally lustrous deposit that can be removed by solvents but not by wiping with a cloth. **D4175**

3.1.16 *wear, n*—the loss of material from a surface, generally occurring between two surfaces in relative motion, and resulting from mechanical or chemical action or a combination of both. **D4175**

4. Summary of Test Method

4.1 The test operation involves use of a Volvo/Mack D13/MP8 diesel engine with Exhaust Gas Recirculation (EGR). A

warm-up and a 1 h break-in are followed by a single-phase test consisting of 360 h at 1500 r/min and fuel flow of 68.0 kg/h.

4.2 Take oil samples periodically and analyze for viscosity increase, oxidation, and wear metals content.

4.3 Rebuild the engine prior to each test. Disassemble, solvent-clean, measure, and rebuild the engine power section using all new pistons, rings, cylinder liners, and connecting rod bearings, in strict accordance with furnished specifications.

4.4 Solvent-clean the engine crankcase and replace worn or defective parts.

4.5 Equip the test stand with appropriate accessories for controlling speed, fuel flow, and various engine operating conditions.

5. Significance and Use

5.1 This test method was developed to evaluate the oxidation resistance performance of engine oils in turbocharged and intercooled four-cycle diesel engines equipped with EGR and running on ultra-low sulfur diesel fuel. Obtain results from used oil analysis and component measurements before and after test.

5.2 The test method may be used for engine oil specification acceptance when all details of the procedure are followed.

6. Apparatus

6.1 General Description:

6.1.1 The test engine is a Volvo/Mack D13/MP8, electronically controlled fuel injection with six electronic unit injectors. It is an open-chamber, in-line, six-cylinder, four-stroke, turbocharged, charge air-cooled, and compression ignition engine.

6.1.2 The ambient laboratory atmosphere shall be relatively free of dirt and other contaminants as required by good laboratory standards. Filtering air, controlling temperature, and controlling humidity in the engine buildup area helps prevent accumulation of dirt and other contaminants on engine parts and aids in measuring and selecting parts for assembly.

6.2 Test Engine:

6.2.1 *Volvo T-13 Test Engine*—The engine is available from TEI. A list of test parts to be replaced for each test is shown in **Table A6.1**. Use test parts on a first-in/first-out basis. A complete engine parts list is available from the TMC website.

6.2.1.1 The engine should be mounted with the flywheel perpendicular to the floor and tilted 4° toward the intake manifold side of the engine.

6.2.2 Engine Cooling System:

6.2.2.1 Use a new Volvo or Mack branded coolant filter, without additives, every test, to limit scaling in the cooling system. Pressurize the system at the expansion tank to 103 kPa. Use the coolant described in **7.3.1**.

6.2.2.2 Remove the thermostat and replace it with a sleeve (P/N 21474103) and seal (P/N 1549651).

6.2.2.3 Use a closed-loop, pressurized external engine cooling system composed of a heat exchanger, reservoir, and water-out temperature control valve. The system shall prevent air entrainment and control jacket temperatures within the

specified limit. Install a sight glass between the engine and the cooling tower to check for air entrainment and uniform flow in an effort to observe and prevent localized boiling.

6.2.2.4 Use a closed-loop, pressurized external EGR cooling system composed of a heat exchanger, reservoir, and coolant-out temperature control valve. The system shall prevent air entrainment and control jacket temperatures within the specified limit. Install a sight glass between the EGR cooler and the cooling tower to check for air entrainment and uniform flow in an effort to observe and prevent localized boiling. The coolant flow direction is to be parallel (concurrent) with the EGR gas flow.

6.2.3 Auxiliary Oil System:

6.2.3.1 To maintain a constant oil level in the pan, provide an additional 9.5 L sump by using a separate closed tank connected to the sump. Circulate oil through the tank with an auxiliary pump. The system schematic is shown in Fig. A5.1. The supply line to the tank from the sump is to have an inside diameter of 16 mm. The return line from the tank to the sump is to have an inside diameter of 12 mm. Use a vent line with a minimum inside diameter of 13 mm. Return line from external oil vessel connected to center of compressor block-off plate. Refer to Fig. A5.2. Vent of external oil vessel connected to cylinder head cover between cylinder 1 and cylinder 2 (see attached). Max length of supply and return line combined: 5.4 m (18 ft).

6.2.3.2 Use a front mount steel oil pan (P/N 21585801) with gasket (P/N 21293367). Remove the oil level sensor. Locate the auxiliary oil system suction line on the exhaust side of the oil pan, down from the oil pan rail 245 mm, and back from the front of the pan 157 mm. Refer to Fig. A5.3. Connect the auxiliary oil system return line to the air compressor block off plate on the rear timing gear cover. Connect the auxiliary oil scale vent line to the top of the auxiliary oil sump bucket and the valve cover.

6.2.3.3 Use Viking Pump Model SG053514⁵ as the auxiliary oil pumps. Pump speed is specified as 1725 r/min.

6.2.3.4 Oil Sampling Port: Size: ¼ in. (No. 4 Aeroquip or equivalent), Max. Length: 2.43 m, Port Location on side of oil filter housing. Refer to Fig. A5.4.

6.2.3.5 Pressurized Oil Filling Connection, see Fig. A5.5, between the oil cooler and the oil filter housing.

6.2.4 Oil Cooling System:

6.2.4.1 Use a US07 Oil Filter Housing (P/N 21183257) and remove the oil thermostat. See Figs. A6.2 and A6.3.

6.2.5 Blowby Meter—Use a meter capable of providing data at a minimum frequency of 6 min. To prevent blowby condensate from draining back into the engine, ensure the blowby line has a downward slope to a collection bucket. Ensure the collection bucket has a minimum volume of 18.9 L. Locate the

blowby meter downstream of the collection bucket. The slope of the blowby line downstream of the collection bucket is unspecified.

6.2.6 Air Supply and Filtration—Use an air filter element and a filter housing appropriate for a heavy duty engine. Install an adjustable valve in the inlet air system at least 2 pipe diameters before any temperature, pressure and humidity measurement devices. Use the valve to maintain inlet air restriction within required specifications.

6.2.6.1 If so equipped remove the inlet air pre-heater element and its housing and replace it with an non-heater-equipped housing. The part number for the non-heated housing is 20730387. This unit also requires bolts (P/N 965184), washers (P/N 976944) and gaskets (P/N 3979639).

6.2.7 Fuel Supply—Heating, cooling, or both of the fuel supply may be required, and a recommended system is shown in Fig. A5.34.

6.2.8 Intake Manifold Temperature Control—Use an intercooler to control intake manifold temperature. Intercooler shall meet the following specifications: pressure drop at test conditions ≤ 5 kPa, provide enough cooling capacity to maintain specified Intake Manifold temperature, and equipped with drain to remove condensate.

6.2.9 Fuel Pressure Regulator—Use a P/N 691GC227M2 fuel pressure regulator.

6.2.10 Engine Control Module (ECM)—Load the test flash file 357309A59 T13 OFFICIAL FINAL Oct 2014 30 Inlet Air.

6.2.11 Exhaust Valvetrain (Rocker Arms and Rocker Arm Shaft)—Use PVD coated exhaust rocker arms (P/N 21474103) with PVD coated rocker arm shaft (P/N 21534995).

6.2.12 Camshaft—Use a non-engine brake camshaft (P/N 21219818) with a Dummy Solenoid Valve (P/N 21105100).

6.2.13 Oil Mist Separator Speed Sensor—Use Detroit Diesel P/N A0061535528 speed sensor with Detroit Diesel P/N A4720180340 bracket and Detroit Diesel P/N A0001506336 connector.

6.2.14 Compressor Block Off Plate—Use Volvo Penta P/N 21226107.

6.2.15 Turbocharger Inlet Rubber Hose, P/N 21659720.

6.2.16 Cool the crank damper with an appropriate method (a fan has been known to cool the damper).

6.2.17 Injector (6), P/N 22027808. Use graphite paste P/N 85134750 for installation.

6.2.18 Turbocharger, P/N 85136177 with gasket with large opening P/N 20781146.

6.2.19 Oil Cooler, ITT Model SSCF 5-160-03-014-004 two pass, all stainless steel; remove cooler core and baffle from engine (right side); plumb the cooler with 1 in. (No. 16 Aeroquip or equivalent) flex lines with a combined max length to and from cooler to be 91.4 cm. Plumb the oil line to the shell side of the cooler and plumb process water to the tube side of the cooler.

6.2.20 Remove the vanes and cartridge from fuel and steering pump assembly.

6.2.21 Flywheel, P/N 20941525 21514067.

6.2.22 Volvo/Mack Valve Cover, P/N 20728586.

⁵ The sole source of supply of the apparatus known to the committee at this time is Viking Pump, Inc., a unit of IDEX Corporation, 406 State Street, P.O. Box 8, Cedar Falls, IA 50613-0008. If you are aware of alternative suppliers, please provide this information to ASTM International Headquarters. Your comments will receive careful consideration at a meeting of the responsible technical committee,¹ which you may attend.

6.2.23 *Crank Pulley*, P/N 20799474; fan pulley P/N 20872502; belt idler (including pulley) P/N 20582550; belt tensioner P/N 21779276; belt P/N 88GB447P615 for correct water pump speed.

6.2.24 Leave the ambient temperature sensor disconnected.

6.2.25 Remove after treatment fuel doser and install connector jumper. Run with fault codes as shown in **Annex A9**.

6.2.26 *EGR Cooler and Coolant Passage Cover*—Modify the coolant passage cover as show in **Fig. A5.34**. Use the fabricated EGR cooler adapter shown in **Fig. A5.35** to connect the EGR cooler inlet to the closed loop external EGR coolant system specified in **6.2.2.4**.

6.2.27 *Fuel Filter Housing*, P/N 21336013.

6.2.28 *Fuel Filter*, P/N 20972295.

6.2.29 *Fuel Water Separator*, P/N 21380521 (plastic bowl/drain P/N 21337071).

6.2.30 CO₂ Intake and Exhaust Measurements: Same probe specifications as Mack T-12; Cool sample to a Dew Point ≤5 °C.

TABLE 1 Test Conditions

Parameters	Limits
Time, h	360
Controlled Parameters ^A	
Speed, r/min	1500
Fuel flow kg/h	68
Coolant Out Temp, °C	110
Oil Gallery Temp, °C	130
Inlet Air Temp, °C	30
Inlet Manifold Temp, °C	78
EGR Gas Out Temp, °C	120
Fuel In Temp, °C	35
Inlet Air Pressure, kPa (absolute)	94
Exhaust Back Pressure, kPa (absolute)	115.3
Inlet Manifold Pressure, kPa (gauge)	232 ± 5
Inlet Air Humidity Ratio, (g/kg)	11.4
Ranged Parameters ^B	
Intake CO ₂	2.01 to 2.11
Engine Coolant Blanket Pressure, kPa (gauge)	99 to 107
EGR Coolant Blanket Pressure, kPa (gauge)	99 to 140
Crankcase Pressure, kPa	-0.3 to 0.3
Uncontrolled Parameters	
Load, N-m	2200
Exhaust CO ₂ , %	Record
Coolant In Temp, °C	Record
Crankcase Pressure, kPa	Record
Pre-Turbine Temp (F), °C	Record
Pre-Turbine Temp (R), °C	Record
Tailpipe Temp, °C	Record
Main Gallery Oil Pressure, kPa	Record
Oil Sump Temp, °C	Record
Oil Jet Temp, °C	Record
Oil Jet Pressure, kPa	Record
Fuel Gallery Temp, °C	Record
Fuel Gallery Pressure, kPa	Record
Intercooler Out Temp, °C	Record
Intercooler Out Pressure, kPa	Record
Compressor Out Temp, °C	Record
Compressor Out Pressure, kPa	Record
Room Temp, °C	Record
EGR Position, %	Record
VGT Position, %	Record
Throttle Position, %	Record
Blowby, L/min	Record
Inlet Air Dew Point, °C	Record

^A All control parameters shall be targeted at the mean indicated.

^B All ranged parameters shall fall within the specified ranges.

7. Engine Fluids

7.1 *Test Oil*—Approximately 76 L of test oil are required for the test.

7.2 *Test Fuel*—Obtain the ultra-low sulfur PC-10 diesel test fuel from a surveillance panel approved supplier. The TMC maintains a list of approved fuel suppliers. The fuel shall have the properties and tolerances shown in the “PC-10 Fuel Specification” section of the “TMC-Monitored Test Fuel Specifications” document maintained by the TMC.⁶

7.3 *Coolant*:

7.3.1 Coolant, Chevron Delo Extended Life Coolant diluted 50/50

P/N 227811 50/50 pre-mixed

P/N 227808 concentrated

7.3.2 The EGR coolant is not specified and is at the discretion of the lab.

7.4 *Cleaning Materials*:

7.4.1 For cleaning engine parts, use only mineral spirits (solvent) meeting the requirements in Specification **D235**, Type II, Class C for Aromatic Content (0 % to 2 % by volume), Flash Point (142 °C, min) and Color (not darker than +25 on Saybolt Scale or 25 on Pt-Co Scale), refer to **A6.4**. (**Warning**—Combustible. Health hazard.) Obtain a Certificate of Analysis for each batch of solvent from the supplier.

7.4.2 Pentane. (**Warning**—Flammable. Health hazard.)

8. Preparation of Apparatus at Rebuild

8.1 *Cleaning of Parts*:

8.1.1 *Engine Block*—Thoroughly spray the engine with solvent to remove any oil remaining from the previous test and air-dry. Follow the optional use of an engine parts washer by a solvent wash.

8.1.2 *Rocker Covers and Oil Pan*—Remove all sludge, varnish and oil deposits. Rinse with solvent and air-dry. Follow the optional use of an engine parts washer by a solvent wash.

8.1.3 *Auxiliary Oil System*—Flush all oil lines, galleries and external oil reservoirs with solvent to remove any previous test oil and then air-dry.

8.1.4 *Oil Cooler and Oil Filter*—Flush the oil cooler and filter lines with solvent to remove any previous test oil and then air-dry. Follow the optional use of an engine parts washer by a solvent wash.

8.1.5 *Cylinder Head*—Clean the cylinder heads using a wire brush to remove deposits and rinse with solvent to remove any sludge and oil and then air-dry. Follow the optional use of an engine parts washer by a solvent wash.

8.1.6 *Intake Manifold*—Clean the intake manifold before each test. Scrub the manifold using a nylon brush and solvent, and then wash the manifold using an engine parts washer.

8.1.7 *EGR Cooler*—Replacing or cleaning of the EGR coolers is at the test laboratory’s discretion. An example of a successful cleaning method is available from the Test Monitoring Center (TMC) (**Annex A1** explains the function of the TMC).

⁶ Available from <https://www.astmtmc.org/ftp/docs/fuel/tmc-monitored%20test%20fuel%20specifications.pdf>.

8.1.8 *EGR Venturi Unit*—Clean the venturi before each test. Spray with solvent and scrub with a nylon brush. Further instruction can be found in the Volvo Service Manual.

8.2 *Valves, Seats, Guides, and Springs:*

8.2.1 Visually inspect valves, seats, and springs for defects or heavy wear and replace if necessary. Replacement of the valves, guides, and seat inserts for each test is recommended, but not required. Refer to the Volvo service manual for cylinder head rebuilding procedure.

8.3 *Cylinder Liner, Piston, and Piston Ring Assembly:*

8.3.1 *Cylinder Liner Fitting*—For proper heat transfer, fit cylinder liners to the block using the procedure outlined in the Volvo Service Manual.⁷

8.3.2 *Piston and Rings*—Cylinder liners, pistons, and rings are provided as a set and shall be used as a set. Examine piston rings for any handling damage. Record the pre-test measurements as detailed in 11.1.

8.4 *Injectors:*

8.4.1 *Injectors*—The electronic unit injectors (EUI) may be changed at any time using the procedure specified in the Volvo Service Manual. Be sure to enter the EUI's calibration code into the Engine Control Module (ECM). The calibration code can be found on the EUI label.

8.5 *Assembly Instructions:*

8.5.1 *General*—The test parts specified for this test are intended to be used without material or dimensional modification. An exception, for example, is approval of a temporary parts supply problem by the surveillance panel, and noting this approval in the test report. All replacement test engine parts shall be genuine Volvo parts. Assemble all parts as illustrated in the Volvo Service Manual except where otherwise noted. Target all dimensions for the means of the specifications. Use Bulldog Oil for lubricating parts during assembly; see A6.7.

8.5.1.1 *Thermostat*—Replace the thermostat with sleeve 21474103. See Fig. A6.1.

8.5.1.2 *Connecting Rod Bearings*—Install new connecting rod bearings for each test. See 10.1 for recording pre-test measurements.

8.5.1.3 *Main Bearings*—Install new main bearings for each test.

8.5.1.4 *Piston Under-Crown Cooling Nozzles*—Particular care shall be taken in assembling the piston under-crown cooling nozzles to insure proper piston cooling (as outlined in the Volvo Service Manual⁷).

NOTE 1—Proper oil pressure is also important to assure sufficient oil volume for proper cooling.

8.5.1.5 *Thrust Washers*—Install new thrust washers for each test.

8.5.2 *New Parts*—Use test parts on a first-in/first-out basis. Install the following new parts for each rebuild; see Table A6.1 for part numbers:

8.5.2.1 Cylinder liners.

8.5.2.2 Pistons.

8.5.2.3 Piston rings.

8.5.2.4 Overhaul gasket set.

8.5.2.5 Oil filters.

8.5.2.6 Engine coolant conditioner.

8.5.2.7 Primary fuel filter.

8.5.2.8 Secondary fuel filter.

8.5.2.9 Valve stem seals.

8.5.2.10 Valve guides.

8.5.2.11 Connecting rod bearings.

8.5.2.12 Main bearings.

8.5.2.13 Thrust washers.

8.5.2.14 Oil Mist Separator Unit.

8.6 *Measurements:*

8.6.1 *Calibrations*—Calibrate thermocouples, pressure gauges, speed, torque and fuel flow measuring equipment prior to each reference oil test or at any time readout data indicates a need. Conduct calibrations with at least two points that bracket the normal operating range. Make these calibrations part of the laboratory record. During calibration, connect leads, hoses and readout systems in the normally used manner and calibrate with necessary standards. For controlled temperatures, immerse thermocouples in calibration baths. Calibrate standards with instruments traceable to the National Institute of Standards and Technology (NIST) on a yearly basis.

8.6.2 *Temperatures:*

8.6.2.1 *General*—Measure temperatures with thermocouples and conventional readout equipment or equivalent. For temperatures in the 0 °C to 150 °C range, calibrate temperature measuring systems to +0.5 °C for at least two temperatures that bracket the normal operating range. Insert all thermocouples so that the tips are located midstream of the flow unless otherwise indicated.

8.6.2.2 *Ambient Air*—Locate thermocouple in a convenient, well-ventilated position from the engine and hot accessories.

8.6.2.3 *Coolant*—Locate the coolant-out thermocouple in the water elbow flange after the thermostat housing. Locate it in the center of the water stream. Refer to Fig. A5.7. Locate the coolant-in thermocouple near the connection to the engine, as shown in Fig. A5.8.

8.6.2.4 *Oil Gallery*—Locate thermocouple on the left gallery of the engine (intake side), as shown in Fig. A5.9. Insertion depth of 64.2 mm from face of engine block.

8.6.2.5 *Oil Sump Temperature*—Using a front oil pan configuration, locate a thermocouple on the intake side of the oil pan, 158.8 mm from the front of the pan and 254 mm from the top of the pan rail. Insertion depth shall be 76.2 mm to 27 mm from the inside wall of the oil pan. Refer to Fig. A5.6 and Fig. A5.10.

8.6.2.6 *Inlet Air Temperature*—Locate the inlet air thermocouple in the center of the air stream leading to the turbo-charger inlet, with the dimensions shown in Fig. 1 below and pictured in Fig. A5.11.

8.6.2.7 *Fuel-In*—Locate thermocouple at connection of fuel inlet fitting on the intake side of the engine, as shown in Fig. A5.12.

8.6.2.8 *Exhaust Tailpipe*—Locate a thermocouple in the exhaust pipe downstream of the exhaust back pressure tap and

⁷ Volvo Service Manuals are available from local Mack Trucks, Inc. distributors.

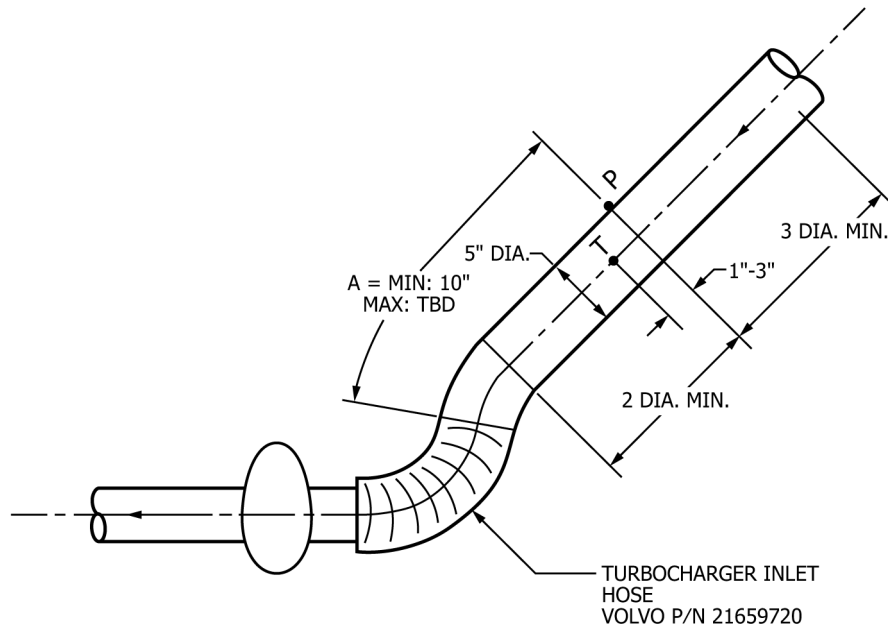

FIG. 1 Inlet Air Piping for the Turbocharger

CO₂ probe using the dimensions shown below in Fig. 2 and pictured in Fig. A5.13.

8.6.2.9 *Intake Manifold*—Locate a thermocouple at the tapped fitting on the intake air manifold as shown in Fig. A5.14.

8.6.2.10 *EGR Cooler Outlet*—Locate thermocouple as shown in Fig. A5.15.

8.6.2.11 *Intercooler Outlet*—Locate the thermocouple downstream of the cooler outlet and prior to the EGR mixer, as shown in Fig. A5.16.

8.6.2.12 *Oil Jet*—Locate the thermocouple on the oil filter housing, as shown in Fig. A5.17. Insertion depths of 78.5 mm from face of oil filter housing.

8.6.2.13 *Fuel Gallery*—Locate the thermocouple in the fuel gallery as shown in Fig. A5.18. Insertion depth of 50.8 mm from face of cylinder head.

8.6.2.14 *Dew Point*—Measure the dew point temperature of fresh air into the engine prior to the turbocharger, but after any temperature reducing or moisture adding equipment.

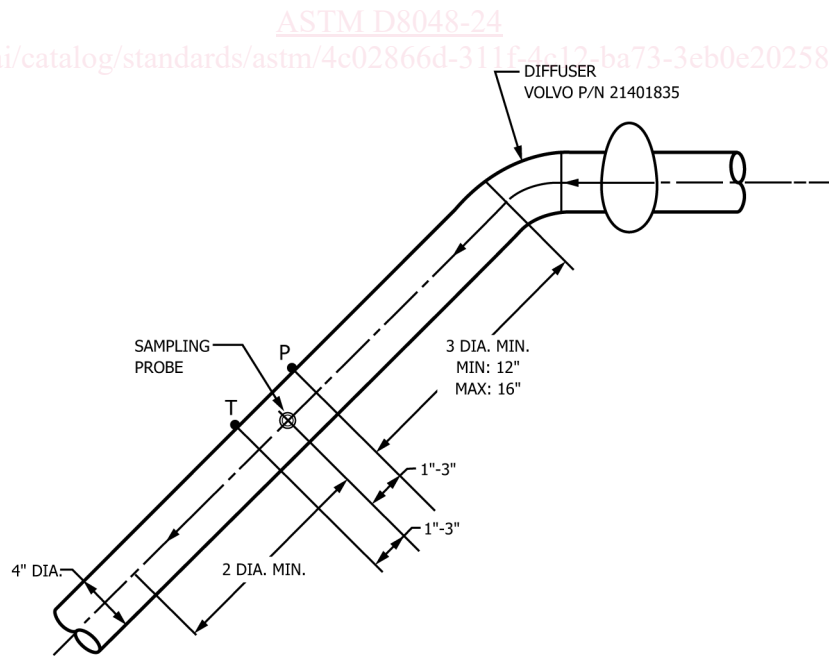

FIG. 2 Exhaust Piping

8.6.2.15 *Compressor Discharge*—Locate the thermocouple between the compressor outlet and the intercooler, as shown in Fig. A5.19. Locate the thermocouple downstream of the compressor outlet pressure tap.

8.6.2.16 *Cylinder Ports*—Locate thermocouples in each cylinder port as shown in Figs. A5.20 and A5.21. This measurement is not mandatory, but it is recommended for diagnostic purposes.

8.6.2.17 *Oil from Cooler*—Locate the thermocouple on the oil filter housing, as shown in Fig. A5.22. Insertion depths of 24.1 mm from face of oil filter housing. This measurement is not mandatory, but it is recommended for diagnostic purposes.

8.6.3 *Pressures:*

8.6.3.1 *After Oil Filter (Main Oil Gallery)*—Locate the pickup on the left side of the engine (intake side). Refer to Fig. A5.23.

8.6.3.2 *Pre-Turbine Exhaust*—Locate the pickup on the exhaust manifold, see Fig. A5.24. This measurement is not mandatory, but it is recommended for diagnostic purposes.

8.6.3.3 *Intake Manifold (Air Boost)*—Take the measurement at the tapped fitting provided on the intake manifold as illustrated in Fig. A5.25.

8.6.3.4 *Intake Air Pressure (Intake Air Restriction)*—Measure it with a static port (pressure tap hole) located upstream of Inlet Air Temperature (see Fig. A5.11).

8.6.3.5 *Exhaust Back Pressure*—Measure exhaust back pressure in a straight section of pipe upstream of the exhaust tailpipe thermocouple, with a pressure tap hole as shown in Fig. A5.13. Do not locate the tap downstream of either the temperature thermocouple or the CO₂ probe.

8.6.3.6 *Crankcase Pressure*—Locate the pickup on the valve cover between cylinder 3 and cylinder 4. Refer to Fig. A5.26.

8.6.3.7 *Compressor Discharge*—Locate the pickup as shown in Fig. A5.19. Locate the pressure tap upstream of the compressor outlet thermocouple.

8.6.3.8 *Coolant System*—Locate the pickup at the top of the coolant system expansion tank, as shown in Fig. A5.27.

8.6.3.9 *Air Cleaner*—Locate pickups to read the pressure differential for both the high and low sides across the air cleaner, as shown in Figs. A5.28 and A5.29.

8.6.3.10 *Coolant Pump*—Locate the pickup on the right side cover, as shown in Fig. A5.30.

8.6.3.11 *Intercooler Outlet*—Locate the pickup at the outlet of the intercooler, as shown in Fig. A5.16. Locate the pressure tap upstream of the intercooler outlet thermocouple.

8.6.3.12 *Fuel Gallery*—Locate the pickup in the fuel gallery, as shown in Fig. A5.31.

8.6.3.13 *Oil Jet*—Locate the pickup on the oil filter housing, as shown in Fig. A5.32.

8.6.3.14 *Cylinder Head Oil*—Locate the pickup in the cylinder head, as shown in Fig. A5.7.

8.6.3.15 *Dew Point Pressure*—Measure the absolute dew point pressure of the inlet air at the same location as the dew point temperature.

8.6.4 *Carbon Dioxide Measurements:*

8.6.4.1 *General*—Calibrate the sensors prior to each measurement taken during the course of the test. The CO₂ levels for

the calibration span gases are specified. The intake span gas CO₂ content shall be 2 % to 4 %. The exhaust span gas CO₂ content shall be 10 % to 15 %. The blend quality for all span gases shall be Primary Standard ± 1 %. The intake and exhaust CO₂ samples shall have a dew point no greater than 5 °C.

8.6.4.2 *Exhaust Carbon Dioxide Probe*—Measure the exhaust CO₂. Locate the probe downstream of the exhaust back-pressure tap. Use a 6.4 mm probe that meets the Code of Federal Regulations, Title 40 Part 86.310-79. The probe diameter is not to exceed the sample line diameter. Refer to Fig. A5.13.

8.6.4.3 *Intake Manifold Carbon Dioxide Probe*—Locate the probe in the intake manifold, as shown in Fig. A5.33. Use a 6.4 mm probe that meets the Code of Federal Regulations, Title 40 Part 86.310-79. The probe diameter is not to exceed the sample line diameter. Inset the probe tip 6.3 mm from the face of the cylinder head.

8.6.5 *System Time Responses*—The maximum allowable system time responses are shown in Table 2. Determine system time responses in accordance with the Data Acquisition and Control Automation II (DACA II) Task Force Report.⁸

9. Procedure

9.1 Pretest Procedure:

9.1.1 *Initial Oil Fill for Pretest Break-In*—The initial oil fill is 25.8 kg of test oil. Pressure fill through the location described in 6.2.3.5.

9.1.2 Pretest Break-In:

9.1.2.1 Run the break-in sequence described in Annex A8.

9.1.2.2 Drain the oil from engine, external oil vessel, and external oil cooler after the break-in is completed within 1 h and allow to drain for at least 30 mins. Replace all oil filters. Refill the engine with 22.8 kg of test oil and conduct the test in accordance with 9.4.

9.2 *Engine Start-Up*—Perform all engine start-ups in accordance with Annex A8. Start-ups are not included as test time. Test time starts as soon as the engine reaches or returns to the test cycle. Record the first time the engine reaches test cycle conditions as the test clock start on the appropriate form.

9.3 Engine Shutdown:

9.3.1 Perform all non-emergency shutdowns in accordance with Annex A8. The shutdown operation does not count as test time. Record the length and reason of each shutdown on the appropriate form.

⁸ The Data Acquisition and Control Automation II Task Force Report may be obtained from the ASTM Test Monitoring Center, 203 Armstrong Drive, Freeport, PA 16229, Attention: Director.

TABLE 2 Maximum Allowable System Time Responses

Measurement Type	Time Response, s
Speed	2.0
Temperature	3.0
Pressure	3.0
Flow	45.0

9.3.2 All operationally valid tests should not exceed 10 shutdowns. Additionally, all operationally valid tests should not exceed downtime of 150 h. Conduct an engineering review if either condition is exceeded.

9.4 Test Cycle:

9.4.1 The test cycle includes a 30 min break-in followed by a 360 h test. Non-reference oil tests may run longer than 360 h provided that all posttest measurements required in 10.2 are performed at the extended EOT and the additional EOT h are reported on the appropriate forms. The official test length, EOT date and time reported should correspond to the 360 h date and time. Operating conditions are shown in Table 1.

9.4.2 Operational Validity—Determine operational validity in accordance with Annex A7.

9.5 Oil Samples—Take 120 mL oil samples according to Table 4. Take the EOT oil sample at start of cool down. Always take oil samples before new oil is added. Obtain oil samples from the pre-filter pressure port, refer to Fig. A5.4. This can be done by installing a tee fitting, a small petcock valve and No. 4 Aeroquip line of length 254 mm to 305 mm, from which the sample is taken. Prior to each sample, take a minimum 140 mL purge. After sample completion, be sure to return the purge to the engine.

9.6 Oil Addition and Drain:

9.6.1 Initially establish the full mark as the oil mass after running at test conditions for 4 h. Follow the oil consumption sampling log sheet in Annex A12.

9.7 Fuel Samples—Take one 120 mL fuel sample at SOT and at EOT.

9.8 Periodic Measurements:

9.8.1 Make measurements at 6 min intervals on the parameters listed in 9.8.2 and record statistics on the appropriate form. Automatic data acquisition is required. Recorded values shall have minimum resolution as shown in Table 3. Characterize the procedure used to calculate the data averages on the appropriate form.

9.8.2 Parameters:

- 9.8.2.1 Speed, r/min.
- 9.8.2.2 Torque, N·m.
- 9.8.2.3 Oil Gallery Temperature, °C.
- 9.8.2.4 Oil Sump Temperature, °C.
- 9.8.2.5 Coolant Out Temperature, °C.
- 9.8.2.6 Coolant In Temperature, °C.
- 9.8.2.7 Intake Air Temperature, °C.
- 9.8.2.8 Intake Manifold Temperature, °C.
- 9.8.2.9 Intake Manifold Pressure, kPa.
- 9.8.2.10 Fuel Flow, kg/h.
- 9.8.2.11 Fuel Inlet Temperature, °C.
- 9.8.2.12 Tailpipe Exhaust Back Pressure, kPa.
- 9.8.2.13 Before Filter Oil Pressure, kPa.
- 9.8.2.14 Main Gallery Oil Pressure, kPa.
- 9.8.2.15 Crankcase Pressure, kPa.
- 9.8.2.16 Pre-Turbine Exhaust Temperature, Front Manifold, °C.
- 9.8.2.17 Pre-Turbine Exhaust Temperature, Rear Manifold, °C.
- 9.8.2.18 Inlet Air Restriction, kPa.
- 9.8.2.19 Tailpipe Exhaust Temperature, °C.
- 9.8.2.20 Crankcase Blowby, L/min (see 9.9).
- 9.8.2.21 Pre-Turbine Exhaust Pressure, Front Manifold, kPa.
- 9.8.2.22 Pre-Turbine Exhaust Pressure, Rear Manifold, kPa.
- 9.8.2.23 Inlet Air Humidity, g/kg.
- 9.8.2.24 EGR Cooler Outlet Temperature, °C.
- 9.8.2.25 EGR Pre-Venturi Temperature, °C.
- 9.8.2.26 Inlet Air Dew Point, °C.
- 9.8.2.27 Oil Mass, kg.
- 9.8.2.28 Intercooler Outlet Temperature, °C.
- 9.8.2.29 Inlet Air Dew Point Pressure, kPa.
- 9.8.2.30 Inlet Air Humidity Ratio, g/kg (calculated, see 9.11).

9.9 Blowby—Record the crankcase blowby on the appropriate form. Take care to prevent oil traps from occurring in the blowby line at any time during operation.

9.10 Carbon Dioxide—Measure and record intake and exhaust CO₂ levels every 8 h.

9.11 Inlet Air Humidity Ratio—The ratio of the partial pressure of water vapor in the air to the vapor pressure of dry air. Calculate the partial pressure of water vapor using Eq 1. Calculate the inlet air humidity ratio using Eq 2 and report on the appropriate form.

$$P_{H2O} = 100 \times 10^{23.5518 + \frac{-2937.4}{D+273}} \times (D + 273)^{-4.9283} \quad (1)$$

$$W = 621.98 \frac{P_{H2O}}{P_{air} - P_{H2O}} \quad (2)$$

where:

- D = dew point, °C,
- P_{air} = partial pressure of air at dew point measurement point, Pa (absolute),
- P_{H2O} = partial pressure of water, Pa (absolute),
- W = inlet air humidity ratio, g/kg, and
- 621.98 = the ratio of the molecular mass of water (18.01534 g/mol) to the molecular mass of dry air (0.0289646 kg/mol).

TABLE 3 Minimum Resolution of Recorded Measurements

Parameter	Record Data to Nearest
Speed	1 r/min
Fuel Flow	0.1 kg/h
Coolant Temperatures	0.1 °C
Fuel In Temperature	0.1 °C
Intake Air Temperature	0.1 °C
Intake Manifold Temperature	0.1 °C
Exhaust Back Pressure	0.1 kPa
Inlet Air Restriction	0.1 kPa
Torque	1 N·m
Power	1 kW
Humidity	0.1 g/kg
Blowby	1 L/min
Inlet Air Dew Point	1 °C
Oil Temperatures	0.1 °C
Exhaust Temperatures	1 °C
EGR Temperatures	1 °C
Oil Pressures	1 kPa
Crankcase Pressure	0.1 kPa
Intake Manifold Pressure	1 kPa
Intake and Exhaust CO ₂	0.01 %
Oil Mass	0.001 kg

TABLE 4 Oil Sampling and Analysis Schedule

Method	D5967-A4	D445-3	D445-5	D664-1	D4739	FTIR T12 IR		FTIR T12 Nitr	D3524M	D5185	Sample Volume
	Soot Mass-Percent TGA	Viscosity at 40 °C mm ² /s	Viscosity at 100 °C mm ² /s	TBN	TAN	IR Oxidation		IR Nitration Peak Height	Fuel Dilution	Wear Metals	
						Integrated	T-13 Peak				
Hours	5 mL	40 mL		35 mL		10 mL		10 mL	10 mL	120 mL	
0	X	X	X	X	X	X	X	X		X	120 mL
24 ^A											120 mL
48	X	X	X	X	X	X	X	X	X	X	120 mL
72 ^A											120 mL
96	X	X	X	X	X	X	X	X		X	120 mL
120	X	X	X	X	X	X	X	X		X	120 mL
144	X	X	X	X	X	X	X	X		X	120 mL
168	X	X	X	X	X	X	X	X		X	120 mL
192	X	X	X	X	X	X	X	X		X	120 mL
216	X	X	X	X	X	X	X	X		X	120 mL
240	X	X	X	X	X	X	X	X		X	120 mL
252		X	X			X	X	X		X	120 mL
264	X	X	X	X	X	X	X	X	X	X	120 mL
276		X	X			X	X	X		X	120 mL
288	X	X	X	X	X	X	X	X		X	120 mL
300		X	X			X	X	X		X	120 mL
312	X	X	X	X	X	X	X	X		X	120 mL
324		X	X			X	X	X		X	120 mL
336	X	X	X	X	X	X	X	X		X	120 mL
348		X	X			X	X	X		X	120 mL
360	X	X	X	X	X	X	X	X	X	X	120 mL

^A 120 mL samples at 24 h and 72 h may be analyzed at the discretion of the lab.

iTeh Standards

<https://standards.iten.ai>

10. Inspection of Engine, Fuel, and Oil

10.1 Pre-Test Measurements:

10.1.1 *Pistons*—No piston measurements are required.

10.1.2 *Piston Rings*—Clean and measure in accordance with the Mack Test Ring Cleaning and Measuring Procedure, available from the TMC. Report results on the appropriate form.

10.1.3 *Connecting Rod Bearings*:

10.1.3.1 Prior to measuring, mark bearings with a single digit on the locating tang to identify cylinder location.

10.1.3.2 Clean the bearings with solvent (see 7.4.1). Use a soft brush if necessary. Air-dry the bearings. Rinse in pentane. Do not handle bearings with bare hands. Use gloves or plastic covered tongs.

10.1.3.3 Weigh bearings on a scale capable of a resolution of 1 mg.

10.2 Post Test Engine Measurements:

10.2.1 *Pistons*—Before removing pistons, carefully remove carbon from top of cylinder sleeve—do not remove any metal.

10.2.2 *Cylinder Liners*—Measure in accordance with Instructions for Measuring Cylinder Liners, available from the TMC. Report the results on the appropriate form.

10.2.3 *Piston Rings*—Clean and measure in accordance with the Mack Test Ring Cleaning and Measuring Procedure, available from the TMC. Report results on the appropriate form.

10.2.4 *Connecting Rod Bearings*:

10.2.4.1 Clean the bearings with solvent (see 7.4.1). Use a soft brush if necessary. Air-dry the bearings. Rinse in pentane. Do not handle bearings with bare hands. Use gloves or plastic covered tongs.

10.2.4.2 Weigh bearings on a scale capable of a resolution of 1 mg.

10.3 *Oil Inspection*—Perform all oil analyses listed in 10.3.1 – 10.3.6 according to the oil sampling schedule in Table 4. Report all results.

10.3.1 *Viscosity*—Analyze oil samples for viscosity at 40 °C and 100 °C in accordance with Test Method D445.

10.3.2 *Metals*—Determine wear metals content (iron, lead, copper, chromium, aluminum, nickel), additive metals content, silicon and sodium levels in accordance with Test Method D5185. Conduct oil analysis as soon as possible after sampling.

10.3.3 *Base Number*—Determine base number in accordance with Test Method D4739.

10.3.4 *Acid Number*—Determine acid number in accordance with Test Method D664.

10.3.5 *Oxidation*—Determine oxidation using both integrated IR and T-13 FTIR Peak Height. The IR measurement procedure documents are available from the TMC.

10.3.6 *Soot*—Conduct soot analysis in accordance with Test Method D5967, Annex A4.

10.4 *Fuel Inspections*:

10.4.1 Use fuel purchase inspection records to ensure conformance to the specifications listed in the “PC-10 Fuel Specification” section of the “TMC-Monitored Test Fuel Specifications” document and to complete the appropriate form for the last batch of fuel used during the test. In addition, perform the following inspections on new (0 h) and EOT (360 h) fuel samples:

10.4.1.1 API Gravity at 15.6 °C, Test Method D287 or D4052.

10.4.1.2 Total Sulfur, mg/kg, Test Method D2622 (D5453, D4294, and D7039 can be substituted). Use one 120 mL sample for inspections.

10.5 Oil Consumption Calculation:

10.5.1 Using the oil mass measurements taken at 6 min intervals (see 9.5); determine the oil consumption in grams per hour by performing linear regression on the data. Do not use the oil consumption data from the first 24 h of the test. For each of the periods from 24 through 240 regress the 24 h period excluding the first hour. Starting at hour 240 and through the end of the test, regress each 12 h period minus the first hour of each period beginning with hour 360. Average together two consecutive 12 h periods to report the 24 h period average oil consumption (as an example 252 and 264, 276 and 288). To calculate the final average oil consumption, average the periods from test hours 25 through 192.

10.5.1.1 Following any shutdowns, oil samples or oil additions exclude from the regression 1 h of oil mass data to account for the stabilizing of the oil scale.

10.5.1.2 If any shutdowns occur during a 24 h period, the result for that 24 h period shall be the weighted average of all the regression slopes that apply to that period. The weighting of a regression slopes is the length of run time associated with it. An example with two shutdowns, one at 109 h and one at 118.5 h is shown in Table 5.

10.5.1.3 Report the average oil consumption for the test on the appropriate form.

11. Laboratory and Engine Test Stand Calibration and Non-Reference Oil Test Requirements

11.1 Calibration Frequency—To maintain test consistency and severity levels; calibrate the test stand at regular intervals.

11.2 Calibration Reference Oils:

11.2.1 The reference oils used to calibrate T-13 test stands have been formulated or selected to represent specific chemical types or performance levels, or both. They can be obtained from the TMC (see Annex A1). The TMC (see Annex A2) assigns reference oils for calibration tests. These oils are supplied under code numbers (blind reference oils).

11.2.2 Reference Oils Analysis—Do not submit reference oils to physical or chemical analyses for identification purposes. Identifying the oils by analyses could undermine the confidentiality required to operate an effective blind reference oil system. Therefore, reference oils are supplied with the explicit understanding that they will not be subjected to analyses other than those specified within this procedure unless specifically authorized by the TMC (see Annex A3). In such

cases where analyses are authorized, supply written confirmation of the circumstances involved, the data obtained, and the name of the person authorizing the analysis to the TMC.

11.3 Test Numbering—Number each T-13 test to identify the test stand number, the test stand run number, engine serial number, and engine rebuild kit number. The sequential stand run number remains unchanged for reruns of aborted, invalid, or unacceptable calibration tests. However, follow the sequential stand run number by the letter A for the first rerun, B for the second, and so forth. For example, 58-12A-2H0380-121 defines a test on stand 58 and stand run 12 as a calibration test that was run twice on engine 2H0380 (serial number) with rebuild kit 121. A test number of 58-14-2H0380-300 defines a test on stand 58 and stand run 14 as a non-reference oil test on engine 2H0380 with rebuild kit 300.

11.4 New Laboratories and New Test Stands:

11.4.1 A new lab is any lab that has never previously calibrated a test stand under this test method (see Annex A4).

11.4.2 A new stand is a test cell and support hardware which has never previously been calibrated under this test method.

11.4.3 Calibrate a new test stand in accordance with the Lubricant Test Monitoring System (LTMS).⁹

11.5 Test Stand Calibration:

11.5.1 Test Stand Calibration—Perform a calibration test on a reference oil assigned by the TMC after ten months or ten operationally valid non-reference tests have elapsed since the completion of the last successful calibration test. An unsuccessful calibration test voids any current calibration on the test stand. A non-reference test stand is defined as when the engine has been installed in the test stand with the test oil and it has been cranked with the intent of firing the engine. Report the date the engine was charged with oil as the oil charged date on the appropriate form. The first time the engine is cranked with the intention of firing the engine is to be reported as the engine start date on the appropriate form.

11.5.2 Test Stand and Engine Combination—For reference and non-reference tests, any engine may be used in any stand. However, use the engines in the test stands on a first available engine basis (FIFO). In other words, there shall be no attempt on the part of the test laboratory to match a particular test stand and engine combination for any given test.

11.5.3 If non-standard tests are conducted on a calibrated test stand, the TMC may require the test stand to be recalibrated prior to running standard tests.

11.6 Test Results:

11.6.1 The specified measurements for reference oil tests are T-13 FTIR peak height oxidation in absorbance (cm) and percent increase in viscosity at 40 °C from 300 h to 360 h.

11.6.2 T-13 FTIR Peak Height Oxidation—Measure the EOT T-13 FTIR peak height oxidation in accordance with 10.3.5 and report in on the appropriate form.

11.6.3 Percent Increase in Viscosity at 40 °C from 300 h to 360 h—Calculate the transformed percent increase in viscosity at 40 °C according to Eq 3 by measuring the viscosity at 40 °C

TABLE 5 24 h Period Oil Consumption Sample Calculation

Oil Scale Data	Time Start (hh:mm)	Time Stop (hh:mm)	Run Time	Regression Slope (g/h)
Stabilizing	100:00	101:00	1:00	n/a
Collecting	101:00	109:00	8:00	40.0
Stabilizing	109:00	110:00	1:00	n/a
Collecting	110:00	118:30	8:30	45.0
Stabilizing	118:30	119:30	1:00	n/a
Collecting	119:30	125:00	5:30	48.5

$$\text{Oil Consumption (100 to 125) h} = \frac{[(8 \times 40.0) + (8.5 \times 45.0) + (5.5 \times 48.5)]}{22} = 44.1 \text{ g/h}$$

⁹ The Lubricant Test Monitoring System may be obtained from the ASTM Test Monitoring Center, 203 Armstrong Drive, Freeport, PA 16229, Attention: Director.

and test hours 300 h and 360 h respectively in accordance with section 10.3.1. Report the transformed percent change on the appropriate form. If the delta between the 360 h and 300 h results is negative, report a value of zero without any correction factors or severity adjustments for the final transformed result on the appropriate form.

$$KV40PC_{\text{Transformed}} = \sqrt{100 \times \frac{KV40_{360} - KV40_{300}}{KV40_{300}}} \quad (3)$$

11.6.3.1 *Correction Factor for Percent Increase in Viscosity at 40 °C from 300 h to 360 h*—For all reference tests on cylinder liner batch B and subsequent liner batches, correct the result from 11.6.3 by adding a correction factor of 0.857 to get the corrected transformed result. For non-reference oil tests completing on or after August 28th, 2023, correct the result from 11.6.3 by adding a correction factor of 0.857 to get the corrected transformed result.

11.7 Reference and Non-Reference Oil Test Requirements:

11.7.1 Determine calibration acceptance in accordance with the Lubricant Test Monitoring System (LTMS)⁹ as administered by the TMC.

11.8 *Non-Reference Oil Test Result Severity Adjustments*—This test method incorporates the use of Severity Adjustments (SA) for non-reference oil test results. A control chart technique, described in the LTMS document, has been selected for determining SA's for T-13 FTIR peak height oxidation, and percent increase in viscosity at 40 °C from 300 h to 360 h.

11.8.1 Determine SA values in accordance with the LTMS document. Report the SA values on the appropriate form, Test Results Summary, in the spaces for SA. Add the pertinent SA value to non-reference oil test results, and enter the severity-adjusted result in the appropriate spaces.

11.8.2 For percent increase in viscosity, if the final severity-adjusted result is less than 0, report the final value as 0.

11.8.3 The SA's remain in effect until new SA's are determined from subsequent calibration test results. Calculate and apply SA's on a laboratory basis.

11.9 *Donated Reference Oil Test Programs*—The surveillance panel is charged with maintaining effective reference oil test severity and precision monitoring. During times of new parts introductions, new or re-blended reference oil additions, and procedural revisions, it may be necessary to evaluate the possible effects on severity and precision levels. The surveillance panel may choose to conduct a program of donated reference oil tests in those laboratories participating in the monitoring system, in order to quantify the effect of a particular change on severity and precision. Typically, the surveillance panel requests its panel members to volunteer enough reference oil test results to create a robust data set. Broad laboratory participation is needed to provide a representative sampling of the industry. To ensure the quality of the data obtained, donated tests are conducted on calibrated test stands. The surveillance panel shall arrange an appropriate number of donated tests and ensure completion of the test program in a timely manner.

11.10 Adjustments to Reference Oil Calibration Periods:

11.10.1 *Procedural Deviations*—On occasions when a laboratory becomes aware of a significant deviation from the test

method, such as might arise during an in-house review or a TMC inspection, the laboratory and the TMC shall agree on an appropriate course of action to remedy the deviation. This action may include the shortening of existing reference oil calibration periods.

11.10.2 *Parts and Fuel Shortages*—Under special circumstances, such as industry-wide parts or fuel shortages, the surveillance panel may direct the TMC to extend the time intervals between reference oil tests. These extensions shall not exceed one regular calibration period.

11.10.3 *Reference Oil Test Data Flow*—To ensure continuous severity and precision monitoring, calibration tests are conducted periodically throughout the year. There may be occasions when laboratories conduct a large portion of calibration tests in a short period of time. This could result in an unacceptably large time frame when very few calibration tests are conducted. The TMC can shorten or extend calibration periods as needed to provide a consistent flow of reference oil test data. Adjustments to calibration periods are made such that laboratories incur no net loss or gain in calibration status.

11.10.4 *Special Use of the Reference Oil Calibration System*—The surveillance panel has the option to use the reference oil system to evaluate changes that have potential impact on test severity and precision. This option is only taken when a program of donated tests is not feasible. The surveillance panel and the TMC shall develop a detailed plan for the test program. This plan requires all reference oil tests in the program to be completed as close to the same time as possible, so that no laboratory or stand, or both calibration is left in an excessively long pending status. In order to maintain the integrity of the reference oil monitoring system, each reference oil test is conducted so as to be interpretable for stand calibration. To facilitate the required test scheduling, the surveillance panel may direct the TMC to lengthen and shorten reference oil calibration periods within laboratories such that the laboratories incur no net loss or gain in calibration status.

12. Report

12.1 For reference oil results, use the standardized report form set available from the ASTM TMC and data dictionary for reporting test results and for summarizing operational data.

NOTE 2—Report the non-reference oil test results on these same forms if the results are intended to be submitted as candidate oil results against a specification.

12.1.1 Fill out the report forms according to the formats shown in the data dictionary.

12.1.2 Transmit results to the TMC within 5 working days of test completion.

12.1.3 Transmit the results electronically as described in the ASTM Data Communications Committee Test Report Transmission Model (Section 2—Flat File Transmission Format) available from the ASTM TMC. Upload files via the TMC's website.

12.2 Report all reference oil test results, whether aborted, invalidated, or successfully completed, to the TMC.

12.3 *Deviations from Test Operational Limits*—Report all deviations from specified test operational limits.