



Designation: **E136--24 E136 - 24a**

An American National Standard

Standard Test Method for Assessing Combustibility of Materials Using a Vertical Tube Furnace at 750 °C¹

This standard is issued under the fixed designation E136; the number immediately following the designation indicates the year of original adoption or, in the case of revision, the year of last revision. A number in parentheses indicates the year of last reapproval. A superscript epsilon (ϵ) indicates an editorial change since the last revision or reapproval.

This standard has been approved for use by agencies of the U.S. Department of Defense.

1. Scope*

1.1 This fire-test-response test method covers the determination under specified laboratory conditions of the combustibility of building materials. Materials passing this test are typically classified as noncombustible materials.

1.2 Limitations of this fire-test response test method are shown below.

1.2.1 This test method does not apply to laminated or coated materials.

1.2.2 This test method is not suitable or satisfactory for materials that soften, flow, melt, intumesce or otherwise separate from the measuring thermocouple or intumesce.

1.2.3 This test method does not provide a measure of an intrinsic property.

1.2.4 This test method does not provide a quantitative measure of heat generation or combustibility; it simply serves as a test method with selected (end point) measures of combustibility.

1.2.5 The test method does not measure the self-heating tendencies of materials.

1.2.6 In this test method materials are not being tested in the nature and form used in building applications. The test specimen consists of a small, specified volume that is either (1) cut from a thick sheet; (2) assembled from multiple thicknesses of thin sheets; or (3) placed in a container if composed of granular powder or loose-fiber materials.

1.2.7 Results from this test method apply to the specific test apparatus and test conditions and are likely to vary when changes are made to one or more of the following: (1) the size, shape, and arrangement of the specimen; (2) the distribution of organic content; (3) the exposure temperature; (4) the air supply; (5) the location of thermocouples.

1.3 This test method includes two options, both of which use a furnace to expose test specimens of building materials to a temperature of 750 °C (1382 °F).

1.3.1 The furnace for the apparatus for Option A consists of a ceramic tube containing an electric heating coil, and two concentric vertical refractory tubes.

¹ This test method is under the jurisdiction of ASTM Committee E05 on Fire Standards and is the direct responsibility of Subcommittee E05.23 on Combustibility. Current edition approved Feb. 1, 2024/March 1, 2024. Published February 2024/March 2024. Originally approved in 1958. Last previous edition approved in 2022/2024 as E136 - 22, E136 - 24. DOI: 10.1520/E0136-24; 10.1520/E0136-24A.

*A Summary of Changes section appears at the end of this standard

1.3.2 The furnace for the apparatus for Option B (Test Method [E2652](#)) consists of an enclosed refractory tube surrounded by a heating coil with a cone-shaped airflow stabilizer.

1.4 This test method references notes and footnotes that provide explanatory information. These notes and footnotes, excluding those in tables and figures, shall not be considered as requirements of this test method.

1.5 The values stated in SI units are to be regarded as standard. The values given in parentheses are for information only.

1.6 *This standard is used to measure and describe the response of materials, products, or assemblies to heat and flame under controlled conditions, but does not by itself incorporate all factors required for fire-hazard or fire-risk assessment of the materials, products, or assemblies under actual fire conditions.*

1.7 *Fire testing is inherently hazardous. Adequate safeguards for personnel and property shall be employed in conducting these tests.*

1.8 *This standard does not purport to address all of the safety concerns, if any, associated with its use. It is the responsibility of the user of this standard to establish appropriate safety, health, and environmental practices and determine the applicability of regulatory limitations prior to use.*

1.9 *This international standard was developed in accordance with internationally recognized principles on standardization established in the Decision on Principles for the Development of International Standards, Guides and Recommendations issued by the World Trade Organization Technical Barriers to Trade (TBT) Committee.*

2. Referenced Documents

2.1 ASTM Standards:²

[D1929](#) Test Method for Determining Ignition Temperature of Plastics

[D3174](#) Test Method for Ash in the Analysis Sample of Coal and Coke from Coal

[E84](#) Test Method for Surface Burning Characteristics of Building Materials

[E176](#) Terminology of Fire Standards

[E2652](#) Test Method for Assessing Combustibility of Materials Using a Tube Furnace with a Cone-shaped Airflow Stabilizer, at 750 °C

2.2 ISO Standard:³

[ISO 871](#) Plastics – Determination of ignition temperature using a hot-air furnace [97b0-bc010d00acf9/astm-e136-24a](#)

[ISO 1182](#) Noncombustibility Test for Building Materials

[ISO 13943](#) Fire Safety – Vocabulary

2.3 Other Standard:

[BS 476](#) Combustibility Test of Materials³

3. Terminology

3.1 Definitions—For definitions of terms found in this test method, refer to Terminology [E176](#) and ISO 13943. In case of conflict, the definitions given in Terminology [E176](#) shall prevail.

4. Summary of Test Method

4.1 This test method uses a furnace to expose building materials to a temperature of 750 °C (1382 °F) until failure occurs or for at least 30 min.

4.2 This test method offers the choice of two options: Option A (Sections 6 through 9) and Option B (Test Method [E2652](#)).

4.3 The furnace for Option A consists of two concentric vertical refractory tubes.

² For referenced ASTM standards, visit the ASTM website, www.astm.org, or contact ASTM Customer Service at service@astm.org. For *Annual Book of ASTM Standards* volume information, refer to the standard's Document Summary page on the ASTM website.

³ Available from American National Standards Institute (ANSI), 25 W. 43rd St., 4th Floor, New York, NY 10036, <http://www.ansi.org>.

4.4 The furnace for Option B (Test Method E2652) consists of an enclosed refractory tube surrounded by a heating coil with a cone-shaped airflow stabilizer.

4.5 Thermocouples are used to assess the temperature increases resulting from combustion of the building material.

4.6 Visual observation is used to assess the occurrence of flaming.

4.7 Section 15 is the report and acceptance criteria section for this test method (both options).

5. Significance and Use

5.1 Materials that pass this test by complying with the criteria in Section 15 are typically classified as noncombustible materials.

5.2 While actual building fire exposure conditions are not duplicated, this test method will assist in indicating those materials which do not act to aid combustion or add appreciable heat to an ambient fire.

5.3 Materials passing the test are permitted limited flaming and other indications of combustion.

6. Apparatus for Option A

6.1 The test apparatus shown in Fig. 1, shall be used for Option A and shall consist primarily of the following:

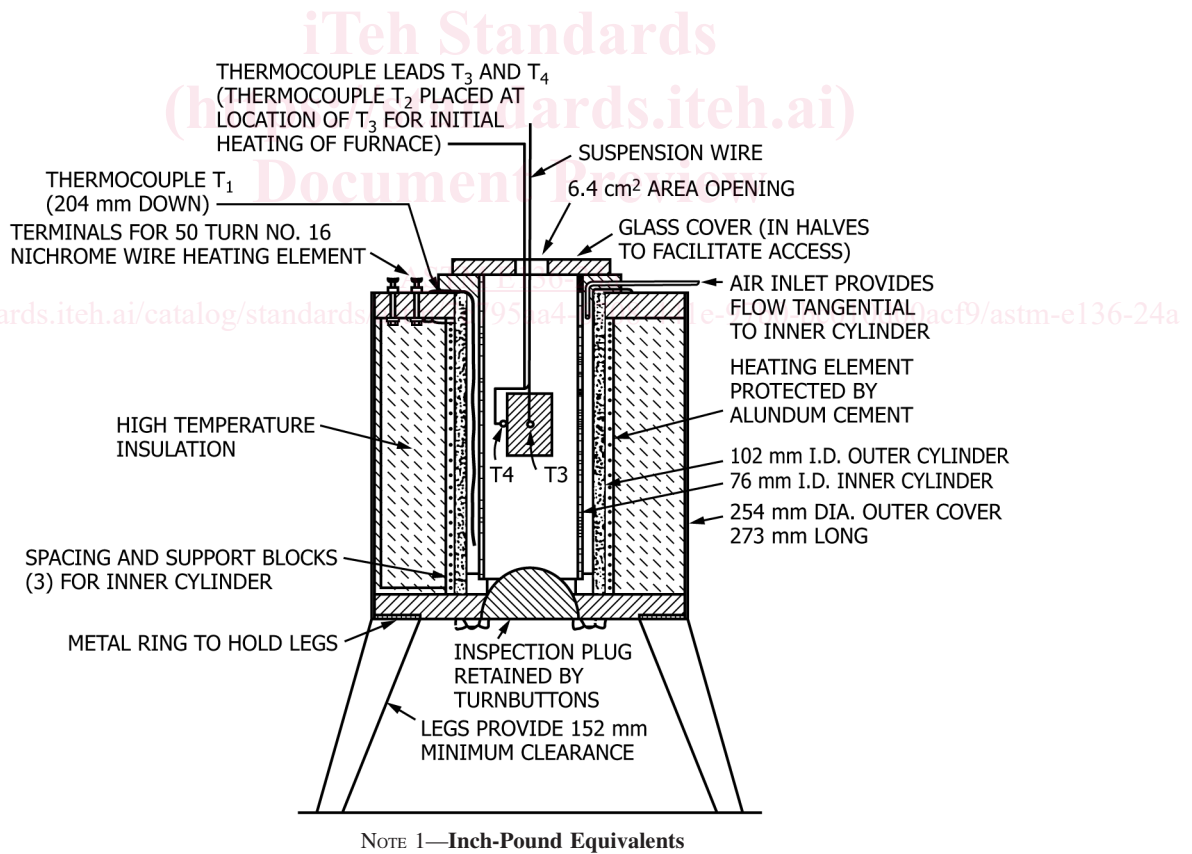

in.	3	4	6	10	10 $\frac{3}{4}$	1 in. ²	No. 16
mm	76	102	152	254	273	6.4 cm ²	Awg 1.29

FIG. 1 Cross Section of Furnace Assembly

6.1.1 *Refractory Tubes*—Two concentric, refractory tubes, 76 mm and 102 mm (3 in. and 4 in.) in inside diameter and 210 mm to 250 mm (8½ in. to 10 in.) in length, with axes vertical, and with heat applied by electric heating coils outside of the larger tube. A controlled flow of air is admitted tangentially near the top of the annular space between the tubes and passes to the bottom of the inner tube. The outer tube rests on a refractory bottom and the inner tube rests on three spacer blocks so as to afford a total opening under the inner tube equal to or greater than that of the annular space. The refractory bottom plate has a removable plug for cleaning.

6.1.2 *Transparent Cover*—A transparent cover of heat-resistant glass or other transparent material shall be provided over the top of the inner tubes. The cover shall have a circular opening 28.7 mm ± 0.8 mm (1⅛ in. ± 1/32 in.) centered over the axis of the tubes. This opening has an area of 645 mm² in. (1.0 in.²). The cover shall be in two equally-sized, movable parts.

6.1.3 *Thermocouples* and an automatically recording device shall be provided. The thermocouples shall be located as follows:

6.1.3.1 Thermocouple T_1 is located in the center of the air space between the two concentric, refractory tubes; approximately 204 mm (8 in.) down from the top of the 102 mm (4 in.) diameter tube (Note 1).

6.1.3.2 Thermocouple T_3 is located at the approximate geometric center of the specimen.

6.1.3.3 Thermocouple T_4 is located on the surface, in contact with the test specimen; in the same horizontal plane as T_3 .

6.1.3.4 Thermocouples T_1 , T_3 and T_4 shall have a time constant (time to reach 63.2 % of the furnace air temperature of 750 °C (1382 °F)) of 5 to 10 s (Note 2).

NOTE 1—Thermocouple T_1 is used for better regulation of the temperature of the air in the furnace space.

NOTE 2—Ungrounded, metallic-sheathed thermocouples of 1-mm diameter have been found to meet the time constant requirements.

6.2 *Specimen Holder*—The specimen holder for solid test specimens shall be as shown in Fig. 2.

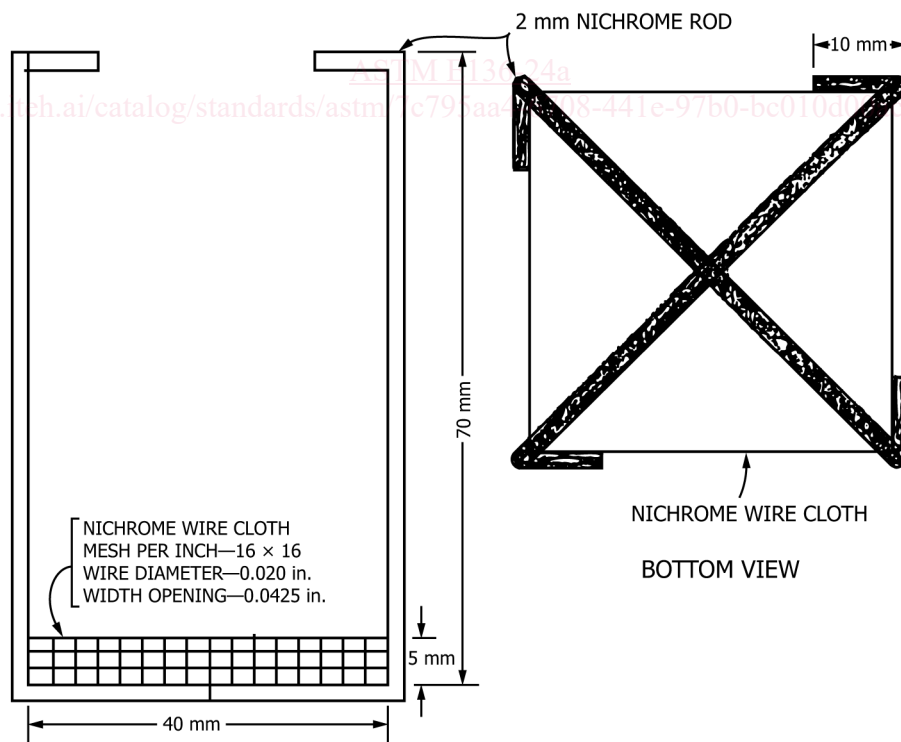

SIDE VIEW

FIG. 2 Specimen Holder for Solid Specimens

6.2.1 Test specimens in granular or powder form shall be contained in thin-wall, open-top vessels of inert materials whose outside dimensions conform to the test specimen shape and maximum size specified in 7.2. These vessels shall have walls of either solid or mesh construction.

6.3 *Test Specimen Location*—During the test, the geometric center of the test specimen shall be located at the geometric center ± 3 mm ($\pm 1/8$ in.) of the 76 mm (3 in.) diameter tube.

7. Test Specimens for Option A

7.1 The test specimens for Option A shall comply with 7.2 through 7.5.

7.2 All test specimens shall be 38 mm by 38 mm by 51 mm ± 2.5 mm (1.5 in. by 1.5 in. by 2.0 in. ± 0.1 in.).

7.3 The test specimens shall be dried at 60 °C ± 3 °C (140 °F ± 5 °F) for not less than 24 h but no more than 48 h.

7.4 Test specimens shall then be placed in a desiccator to cool at least 1 h before testing.

7.5 Not less than four identical specimens shall be tested.

8. Procedure for Option A

8.1 The procedure for Option A shall comply with 8.2 through 8.11.

8.2 *Test Room Setup:*

8.2.1 Conduct the test at room conditions of 21 °C ± 3 °C (70 °F ± 5 °F).

8.2.2 The test apparatus shall not be exposed to drafts or any other form of direct sunlight or artificial illumination which would adversely affect the observation of flaming inside the furnace.

8.2.3 The room temperature shall not change by more than 3 °C (5 °F) during a test.

8.3 *Air Flow*—Provide an external air source to supply clean air through a metal tube located near the top of the test apparatus, tangentially between the annular spaced ceramic tubes. The air shall be supplied at a steady and controllable rate of 0.0027 m³/min (0.10 ft³/min) ± 20 %, which will give an air flow of 3 m (10 ft)/min past a loaded test specimen in the furnace at 750 °C (1382 °F). Measure the air at room temperature, as specified in 8.2.1 and meter by a rotameter or other metering device in line with the metal tube.

8.4 *Stabilized Furnace Temperature*—Prior to the initial heating period insert a thermocouple, T_2 , into the furnace from the top and place it where the geometric center of the test specimen will be during the test. Use this thermocouple to establish the stabilized furnace temperature.

8.5 *Test Furnace Setup*—Prepare the furnace by bringing the temperature of thermocouple T_2 , located in the furnace at the position to be occupied by the geometric center of the specimen, to a temperature of 750 °C ± 5.5 °C (1382 ± 10 °F). Maintain the temperature in the unloaded furnace for at least 15 min to ensure stability.

8.6 Once the operating temperature has been established by thermocouple, T_2 , monitor and record the temperature on thermocouple T_1 during the test.

8.7 *Test Procedure*—As rapidly as possible, insert the test specimen into the furnace with thermocouple T_3 inserted from the top of the test specimen to its geometric center and thermocouple T_4 attached to the side surface of the test specimen.

8.7.1 Close the top cover to the 6.4 cm² (1 in.²) opening immediately after insertion of the test specimen. Readings for

thermocouples T_3 and T_4 shall be made at intervals (**Note 3**) not to exceed 10 s during the first 5 min, and as often as necessary afterwards to produce a smooth curve. Do not change the regulation of the current through the heating coils and the air flow during the test.

NOTE 3—A continuous read-out recording is preferred since it is possible for the maximum temperature to occur between the 10-s intervals.

8.7.2 Continue the test until the temperatures at thermocouples T_3 and T_4 have reached maxima, or until it is evident that the specimen does not pass this test.

8.7.3 After 30 min of testing have elapsed, or at any time subsequent to that, testing shall be discontinued if, over the previous 10 minutes, the temperature measured at the center thermocouple T_3 has risen by no more than 1 °C in any one minute. The final temperature reading shall be recorded as the maximum temperature.

8.8 Throughout the test make and record visual observations on the test specimens, noting quality, quantity, or intensity and duration of flaming or smoking, or both, and change of state.

8.9 Note and record the time of occurrence of any flaming and the duration of such flaming in seconds.

NOTE 4—Flaming is sometimes difficult to identify. Some specimens exhibit only flame as a steady blue-colored luminous gas zone. Do not ignore this and note it under “observations during test” in the test report.

8.10 Weigh each test specimen before and after testing and record the weight, in g, before and after the test for each test specimen.

8.11 Record the temperatures (initial, maximum and final), in °C, as measured by the appropriate thermocouples.

9. Calculation for Option A

9.1 The calculations for Option A shall be conducted in accordance with 9.2 through 9.3.

9.2 Calculate and record the weight loss for each of the test specimens, expressed as a percentage of the initial weight of the test specimen, to the nearest 1 %.

9.3 Calculate and record the temperature rise, in °C, for each of the test specimens.

9.3.1 Calculate the temperature rise as the difference between the maximum temperature and the initial temperature, as measured by thermocouple, T_3 .

10. Apparatus for Option B

10.1 The apparatus used for Option B shall be in accordance with Section 6 of Test Method **E2652**.

10.2 When the apparatus of Test Method **E2652** is used to assess the behavior of building materials in accordance with Test Method E136, measurements shall be made using both the test specimen center thermocouple specified in 6.4.5.1 of Test Method **E2652** and the test specimen surface thermocouple specified in 6.4.5.2 of Test Method **E2652**. The values shall be reported as required in Section 15 of Test Method E136 (see also Appendix **X1.8**).

11. Test Specimens for Option B

11.1 The test specimens used for Option B shall be in accordance with Section 7 of Test Method **E2652**.

12. Test Setup and Calibration for Option B

12.1 The test specimens for Option B shall be in accordance with Section 8 of Test Method **E2652**.