



Designation: D4296 – 24

Standard Practice for Sampling Pitch¹

This standard is issued under the fixed designation D4296; the number immediately following the designation indicates the year of original adoption or, in the case of revision, the year of last revision. A number in parentheses indicates the year of last reapproval. A superscript epsilon (ϵ) indicates an editorial change since the last revision or reapproval.

1. Scope*

1.1 This practice covers procedures for sampling pitch at points of manufacture, storage, and delivery.

1.2 The values stated in SI units are to be regarded as standard. The values in parentheses are for information only.

1.3 *This standard does not purport to address all of the safety concerns, if any, associated with its use. It is the responsibility of the user of this standard to establish appropriate safety, health, and environmental practices and determine the applicability of regulatory limitations prior to use.* Specific warning statements are given in Section 12.

1.4 *This international standard was developed in accordance with internationally recognized principles on standardization established in the Decision on Principles for the Development of International Standards, Guides and Recommendations issued by the World Trade Organization Technical Barriers to Trade (TBT) Committee.*

2. Referenced Documents

2.1 *ASTM Standards:*²

D4175 [Terminology Relating to Petroleum Products, Liquid Fuels, and Lubricants](https://standards.iteh.ai/catalog/standards/astm/e112b670c13f5dfb70c/astm-d4175)

3. Terminology

3.1 *Definitions:*

3.1.1 For definitions of terms used in this practice, refer to Terminology D4175.

3.1.2 *bulk sample, n*—the reduced and divided representative portion of the gross sample as prepared for shipment to and received by a laboratory to be prepared for analysis.

3.1.3 *composite sample, n—in pitch*, a sample, representative of an entire consignment of pitch, generated by mixing

¹ This practice is under the jurisdiction of ASTM Committee D02 on Petroleum Products, Liquid Fuels, and Lubricants and is the direct responsibility of Subcommittee D02.05 on Properties of Fuels, Petroleum Coke and Carbon Material.

Current edition approved March 1, 2024. Published April 2024. Originally approved in 1983. Last previous edition approved in 2018 as D4296 – 18. DOI: 10.1520/D4296-24.

² For referenced ASTM standards, visit the ASTM website, www.astm.org, or contact ASTM Customer Service at service@astm.org. For *Annual Book of ASTM Standards* volume information, refer to the standard's Document Summary page on the ASTM website.

portions of gross samples from different lots together in mass fraction proportioned to the consignment.

3.1.4 *gross sample, n—in pitch*, the original, uncrushed representative portion taken from a shipment of pitch.

3.1.5 *increment, n*—a portion of a material to be combined with other portions of the same material to provide a larger sample which will represent the whole material.

3.1.6 *representative sample, n*—a portion extracted from a total volume that may or may not contain the constituents in the same proportions are present in the total volume.

3.1.7 *sample, n*—a part taken as representative of a whole material.

4. Summary of Practice

4.1 Samples of liquid pitches are taken from process lines, storage, and shipment containers in increments required to prepare a representative sample for testing.

4.2 Samples of solid pitches are taken from loading systems, storage, and shipment containers in increments required to prepare a representative sample for testing.

5. Significance and Use

5.1 Sampling is as important as testing. If the sampling is improperly done, the sample of the material will be in error, and the analysis will not represent the true properties of the material, and it may be impossible or impracticable to take another sample; whereas, if the sample is properly taken and the analysis is in error, another analysis can readily be made of the original sample.

5.2 Samples may be taken for either of the following two purposes:

5.2.1 To represent as nearly as possible an average of the bulk of the materials sampled, or

5.2.2 To ascertain the maximum variation in characteristics which the material possesses.

5.3 A good sampling plan has the following characteristics:

5.3.1 It protects the consumer against the acceptance of a bad batch of material.

5.3.2 It protects the producer against the rejection of a good batch of material.

5.3.3 It gives long-range protection to the consumer.

*A Summary of Changes section appears at the end of this standard

5.3.4 It encourages the producer to keep his process in control.

5.3.5 It minimizes the cost of sampling, inspection of testing, and administration.

5.3.6 It provides information concerning the quality of the product.

5.4 *Sampling Integrity*—When one takes a sample, one is attempting to represent a batch or lot of material with that sample. Different forms of pitch, and pitch in different types of containers, need to have different sampling plans and appropriate sampling equipment. Each sampling plan should be designed so that it accomplishes its objective, which is to ascertain the characteristics or quality of a batch or lot of material.

6. Selection of Samples

6.1 Pitches shall be sampled by the producer at the point of manufacture or storage, and at such time as to allow the tests controlling acceptance or rejection of quality, as specified by the consumer, to be made in advance of a shipment.

6.2 Samples of pitches shall be taken by the consumer from the shipment containers immediately upon delivery and receipt and tests controlling acceptance or rejection of quality, as described by the consumer's specifications, shall be made as soon as possible.

7. Size of Samples

7.1 The sample size of liquid materials shall be as follows:

7.1.1 From process lines, 1 L (1 qt).

7.1.2 From bulk storage, 1 L (1 qt) or 1 L aliquot of composite sample.

7.1.3 From bulk shipment containers, 1 L (1 qt) or 1 L aliquot of composite sample.

7.1.4 From barrels or drums, 0.5 L (1 pt) or 0.5 L aliquot of composite sample.

7.2 The sample size of solid materials shall be as follows:

7.2.1 From storage area, 4 L (1 gal) or 4 L aliquot of composite sample.

7.2.2 From bulk shipment containers, 4 L (1 gal) aliquot of composite sample.

7.2.3 From barrels or drums, 0.5 L (1 pt) or 0.5 L aliquot of composite sample.

8. Collection of Gross Sample

8.1 A collection of gross sample represents a lot or batch of material and is composed of a number of increments.

8.1.1 Collect the increments regularly and systematically, so that the entire quantity of pitch sampled will be represented proportionately in the gross sample, and with such frequency that a gross sample of the required amount will be collected.

9. Size of Increments

9.1 To collect samples, use a shovel or specially designed tool or mechanical means for taking equal portions or increments. When samples are collected from the surface of loaded shipments, the gross sample shall consist of nine increments of approximately equal quantity. When sampling from piles,

conveyer belts, and so forth, the gross sample shall consist of not less than 25 nor more than 50 increments of approximately equal quantity.

10. Protection and Preservation of Samples

10.1 Sample containers shall be new or reusable containers which can be thoroughly cleaned with a solvent and wiped dry with a clean dry cloth.

10.2 Care shall be taken to prevent the sample from becoming contaminated. Immediately after filling, hot liquid sample containers shall be positively covered, but not tightly sealed. Containers of solid materials shall be tightly and positively sealed.

10.3 While sampling during inclement weather, attention shall be paid to prevent water from dropping into the hot liquid sample or samples of solid materials.

10.4 Immediately after filling and sealing, the sampling containers shall be properly marked for identification with a suitable pencil on the container itself, not on the lid.

11. Apparatus

11.1 Sampling Equipment for Liquid Materials:

11.1.1 If so equipped, pipe lines and storage tanks may be sampled from valves installed in the lines or up the side of the tanks. A typical tank valve is shown in Fig. 1, and suitable line valves are illustrated in Fig. 2 and Fig. 3.

11.1.2 For sampling tank trucks, a pipe connection with attached sample valve similar to the one shown in Fig. 2 may be inserted between the outlet pipe and unloading line.

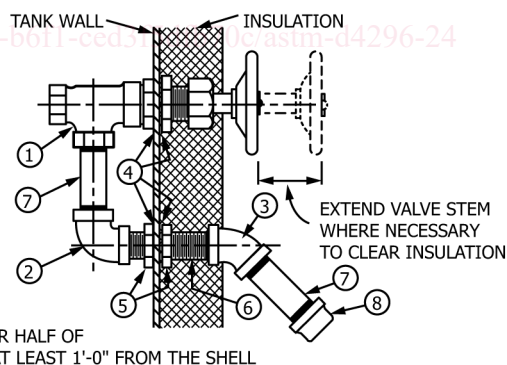

MOUNT IN LOWER HALF OF THE BULKHEAD AT LEAST 1'-0" FROM THE SHELL

REF. NO.	DESCRIPTION	NO. REQ.
1	¾" "VOGT" P-9844 STEEL ANGLE VALVE OR SIMILAR, PANEL MOUNTED	1
2	¾" STEEL OR MALL. IRON 90° ELBOW	1
3	¾" STEEL OR MALL. IRON 45° ELBOW	1
4	ASBESTOS GASKETS SNUG ON THREAD OR WOUND WITH YARN	4
5	¾" 150# SCREWED M. I. LOCKNUT	2
6	¾" × 3½" ± PARALLEL THREADED STEEL PIPE NIPPLE (CUT FROM ¾" STD. TANK NIPPLE IF OTHERWISE UNOBTAINABLE)	1
7	¾" × 3" THREADED STEEL PIPE NIPPLE	2
8	¾" MALL. IRON PIPE CAP	1

FIG. 1 Typical Submerged Sampling Device



FIG. 2 In-Line Sampling Device

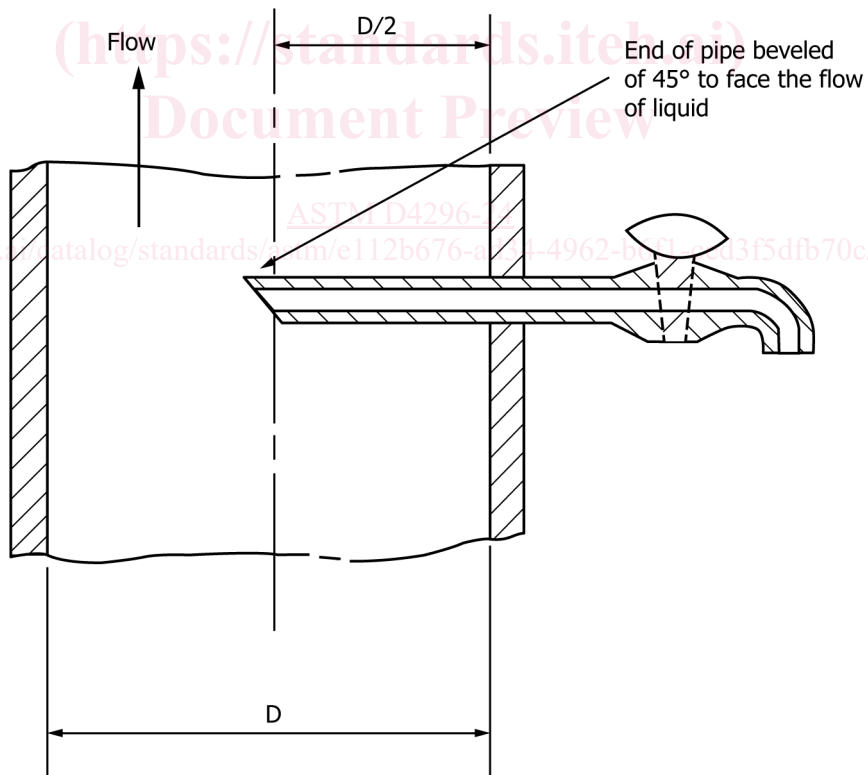

FIG. 3 Pipeline Sampler

11.1.3 A weighted sample bottle similar to those shown in Fig. 4 and Fig. 5, or a “thief sampler” as shown in Fig. 6, or a

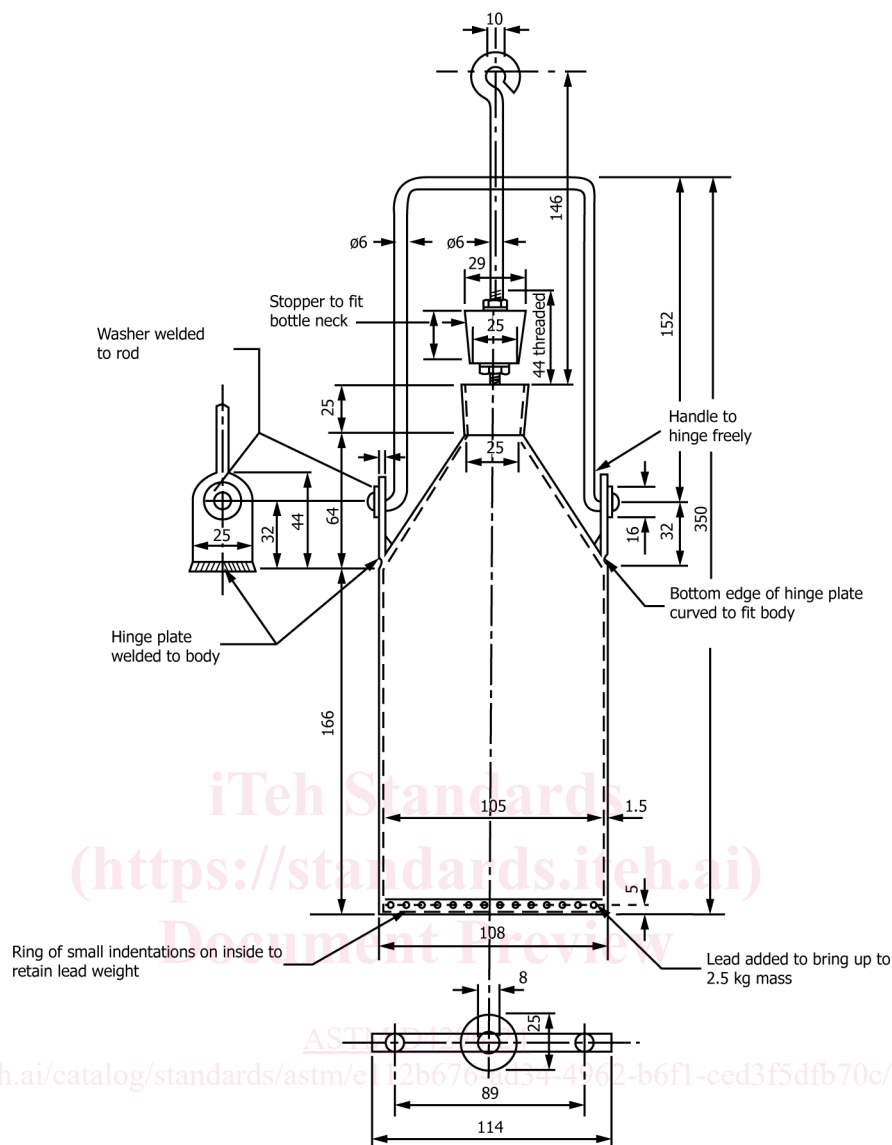

FIG. 4 Weighted Sampling Can

“dip sampler” similar to that shown in Fig. 7, may be used to sample production and storage tanks, tank cars, and tank trucks.

11.1.4 A “tube” or “thief” sampler may be used to sample materials in drums or barrels.

11.2 Sampling Equipment for Solid Materials:

11.2.1 Samples from loading systems may be taken with a shovel, metal or plastic scoop, or metal can.

11.2.2 A shovel may be used to sample storage bins, pitch piles, pitch bays, hopper cars, and dump trucks.

11.2.3 A sampling spear as shown in Fig. 8 may be used to sample materials in drums, barrels, bags, and silos.

11.3 Sampling Containers:

11.3.1 Containers for liquid materials shall be wide-mouth cans with line screw caps or triple-seal friction-top cans.

11.3.2 Containers for formed pitches or crushed solid pitch shall be triple-seal friction-top cans, sealable plastic or paper cartons with inert inside coating, plastic sacks placed in other containers suitable for handling, or substantial strength paper bag which can be stapled closed.

11.4 Mixing Equipment for Solid Materials:

11.4.1 Section of clean canvas or plastic sheet of sufficient size to contain a large bulk sample which is to be reduced by mixing and quartering.

11.4.2 A “riffle” as shown in Fig. 9 may be used for reducing gross samples to smaller sizes for testing.

11.4.3 A “shovel” may be used to reduce gross samples to smaller sizes by mixing and quartering as shown in Fig. 10.

11.5 Mixing Equipment for Liquid Materials:

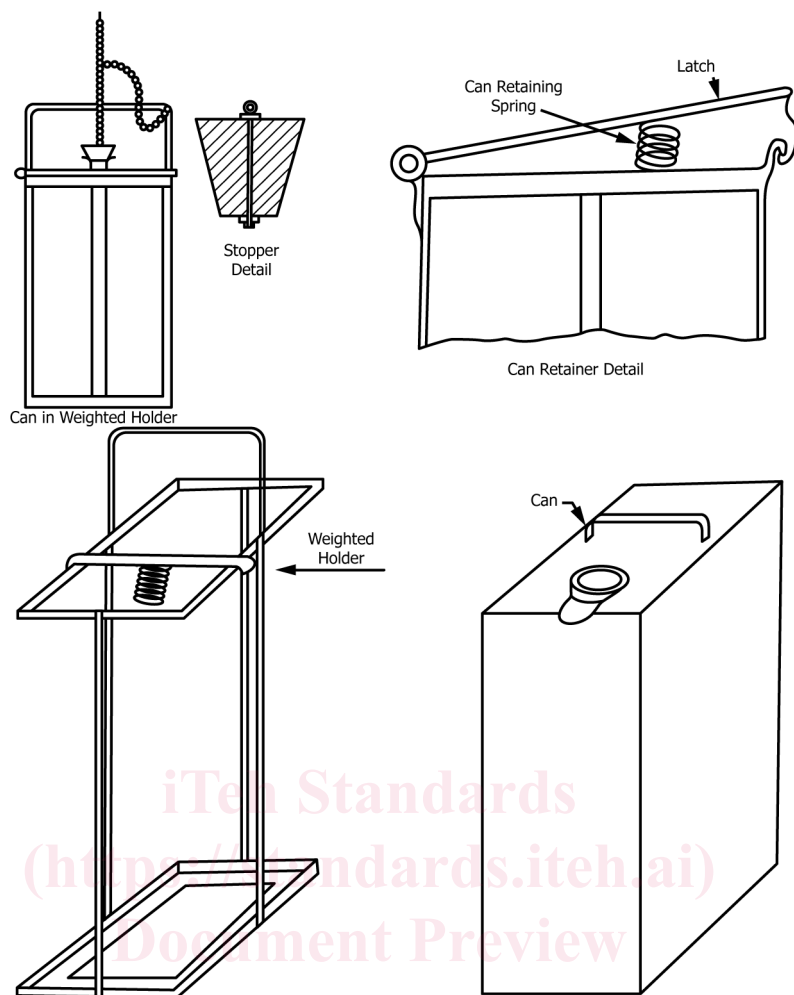

NOTE 1—This type sampler is lowered into the tank with the stopper in place. When the desired depth is reached, the stopper is removed by means of the attached wire, cord, or chain and the container allowed to fill. Complete filling is indicated by the cessation of bubbles of air from the can at the surface of the liquid. The sampler is then withdrawn from the tank and the contents poured into the clean sampler container. A clean can (bottle) must be used for each sample taken.

FIG. 5 Throw-Away Container Sampler

11.5.1 Sample sizes of 4 L (1 gal) or less can be mixed by thorough stirring with a metal rod or wide blade metal paddle.

11.5.2 A heavy duty electric stirrer is recommended for sample volumes over 4 L (1 gal) to 20 L (5 gal) in size.

12. Hazards

12.1 The sampler shall wear protective clothing, goggles, and rubber or heat-resistant gloves to protect oneself from accidental contact with hot liquid pitch.

12.2 For prolonged exposure to the presence of pitch vapors or pitch dust, a suitable respirator mask should be worn to avoid inhalation of pitch vapors or dust. It is recommended that an appropriate barrier cream be applied to exposed areas of the skin.

12.3 Sampling from rail cars shall be avoided when there is a possibility of shunting operations taking place. It is recommended that flags be placed on both ends of the car to prevent accidental movement during sampling.

12.4 It is recommended that no fewer than two persons be present when samples are taken from hot bulk vessels such as storage tanks, tank cars, and tank trucks.

13. Sampling Liquid Pitch

13.1 The following three sampling methods are recommended for sampling vertical tanks not capable of being agitated:

13.1.1 *Sample-Valve Method*—Locate valves, with easy and safe access provided, on the side of the tank with the first in the top third of the tank, but no higher than 1 m (3 ft) from the top; the second in the middle of the tank; and the third in the bottom third of the tank, but no lower than 1.1 m (3½ ft) from the bottom. A recommended design of the sample valve is shown in Fig. 1. Draw a minimum of 4 L (1 gal) of the product from each sample valve for test or composite.

13.1.2 *Thief Sampling Method*—Take samples at the top, middle and lower sections of the tank by lowering a thief sampler into the material. A satisfactory type with instructions

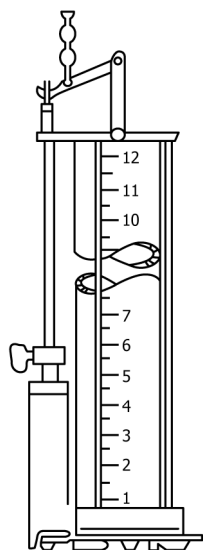

NOTE 1—This type sampler is lowered into the tank with bottom valve open (there is no top closure). When the desired depth is reached, the lowering chain is given a snap tug which closes the bottom valve. The sampler is then withdrawn from the tank and the contents transferred to the sample container. This sampler may be used for repetitive sampling in the same tank.

FIG. 6 Thief Sampler

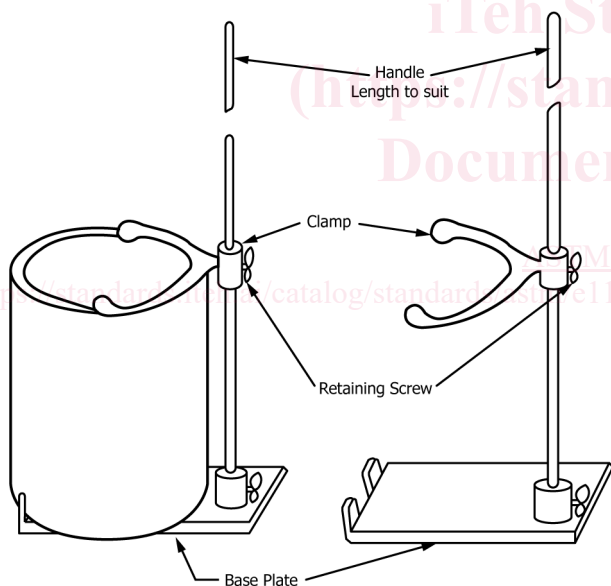

NOTE 1—Sampler with can secured in place is rapidly lowered into tank to desired depth and allowed to fill with sample. The sampler is then withdrawn from the tank and the contents transferred to the sample container. A clean container *must* be used to take each sample.

FIG. 7 Dip Sampler

for use is shown in Fig. 6. The samples may be tested separately or combined and mixed thoroughly for a composite analysis.

13.1.3 *Weighted Sample Bottle Method*—Take samples at the top, middle, and lower sections of the tank by lowering the bottle into the material. Two types of weighted sampling bottles are illustrated in Fig. 4 and Fig. 5.

13.1.3.1 The essential feature of the method is to drop the stoppered bottle into the material to the desired depth, and then pull the stopper by means of an attached chain. When the material fills the bottle, lift out of the liquid and empty into a clean container. Drain the bottle as completely as possible, re-insert the stopper, lower into the material to the next sampling depth.

13.1.3.2 Normally, there is not enough undrained residue from the first sample to affect the properties of the next sample taken from a different level. However, if substantial material difference is suspected at various levels of the material, discard the first of successive samples to rinse the bottle and then return the bottle to the same level for another sample.

13.1.3.3 The three samples may be tested separately for consistency to detect stratification or they may be combined, thoroughly mixed, and a 1 L to 4 L (¼ gal to 1 gal) aliquot of the composite taken for determining the average characteristics of the material.

13.2 *Sampling Bulk Storage Tanks Equipped with Mechanical Agitators or Recirculating Pumps*—When the tank is equipped with operating mechanical agitators or recirculating pumping systems which are performing adequate mixing of the tank contents, take a single sample by any of the methods described in 13.1.1, 13.1.2, or 13.1.3 to use for test purposes.

13.3 *Sampling Tank Cars and Tank Trucks:*

13.3.1 Samples of hot liquid materials may be taken by the dip method using a clean wide-mouth or friction-top can in a suitable holder or firmly attached to a metal rod. One such dip apparatus is shown in Fig. 7. Quickly lower the dip sample about 0.3 m (1 ft) below the surface of the liquid and carefully remove. Use a clean container to take each sample, and then transfer the material sampled to another clean container for retention and testing.

13.3.2 If incremental samples are required for subsequent composite, samples may be taken as described in 13.1.2 or 13.1.3.

13.3.3 When tank cars or tank trucks are being loaded or unloaded, samples may conveniently be taken from the pipe line through which material is flowing by insertion of a sampling pipe into the rising section of the pipe line on the discharge side of the pump, or in a completely filled line in which gravity creates the material's flow.

13.3.3.1 A suitable in-line sampling pipe is shown in Fig. 2 and Fig. 3. Turn the opening of the sampling pipe to face the flow of the liquid. Provide the pipe with a valve or plug cock and discharge into a sample receiver. Before the sample is taken, draw 4 L (1 gal) of the material from the pipe valve and discard.

13.3.3.2 Take samples of 1 L (1 qt) at such frequency during the loading or unloading to provide a 4 L to 8 L (1 gal to 2 gal) composite of the material. At the completion of the loading or unloading, thoroughly mix the collected sample and take a 0.5 L to 4 L (⅛ gal to 1 gal) portion for testing.

13.4 *Sampling from Drums or Barrels:*

13.4.1 High-softening point pitches poured into drums for storage and shipment will solidify at ambient temperatures and sampling should be made in accordance with the procedure in 12.5.