



Designation: D1857/D1857M – 24

# Standard Test Method for Fusibility of Coal and Coke Ash<sup>1</sup>

This standard is issued under the fixed designation D1857/D1857M; the number immediately following the designation indicates the year of original adoption or, in the case of revision, the year of last revision. A number in parentheses indicates the year of last reappraisal. A superscript epsilon ( $\epsilon$ ) indicates an editorial change since the last revision or reappraisal.

*This standard has been approved for use by agencies of the U.S. Department of Defense.*

## 1. Scope\*

1.1 This test method covers the observation of the temperatures at which triangular pyramids (cones) prepared from coal and coke ash attain and pass through certain defined stages of fusing and flow when heated at a specified rate in controlled, mildly reducing, and where desired, oxidizing atmospheres.

1.2 The test method is empirical, and strict observance of the requirements and conditions is necessary to obtain reproducible temperatures and enable different laboratories to obtain concordant results.

1.3 The values stated in either SI units or inch-pound units are to be regarded separately as standard. The values stated in each system may not be exact equivalents; therefore, each system shall be used independently of the other. Combining values from the two systems may result in non-conformance with the standard.

1.3.1 All percentages are percent mass fractions unless otherwise noted.

1.4 *This standard does not purport to address all of the safety concerns, if any, associated with its use. It is the responsibility of the user of this standard to establish appropriate safety, health, and environmental practices and determine the applicability of regulatory limitations prior to use.*

1.5 *This international standard was developed in accordance with internationally recognized principles on standardization established in the Decision on Principles for the Development of International Standards, Guides and Recommendations issued by the World Trade Organization Technical Barriers to Trade (TBT) Committee.*

## 2. Referenced Documents

2.1 *ASTM Standards:*<sup>2</sup>

<sup>1</sup> This test method is under the jurisdiction of ASTM Committee D05 on Coal and Coke and is the direct responsibility of D05.21 on Methods of Analysis.

Current edition approved April 1, 2024. Published April 2024. Originally approved 1961. Last previous edition approved in 2018 as D1857/D1857M – 18. DOI: 10.1520/D1857\_D1857M-24.

<sup>2</sup> For referenced ASTM standards, visit the ASTM website, www.astm.org, or contact ASTM Customer Service at service@astm.org. For *Annual Book of ASTM Standards* volume information, refer to the standard's Document Summary page on the ASTM website.

- D346/D346M Practice for Collection and Preparation of Coke Samples for Laboratory Analysis
- D2013/D2013M Practice for Preparing Coal Samples for Analysis
- D3174 Test Method for Ash in the Analysis Sample of Coal and Coke from Coal
- D3682 Test Method for Major and Minor Elements in Combustion Residues from Coal Utilization Processes by Atomic Spectrometry
- D4326 Test Method for Major and Minor Elements in Coal Ash By X-Ray Fluorescence
- D6349 Test Method for Determination of Major and Minor Elements in Coal, Coke, and Solid Residues from Combustion of Coal and Coke by Inductively Coupled Plasma—Atomic Emission Spectrometry
- D7448 Practice for Establishing the Competence of Laboratories Using ASTM Procedures in the Sampling and Analysis of Coal and Coke (Withdrawn 2024)<sup>3</sup>
- D7582 Test Methods for Proximate Analysis of Coal and Coke by Macro Thermogravimetric Analysis

## 3. Terminology

3.1 *Definitions of Terms Specific to This Standard:*

3.1.1 The critical temperature points to be observed are as follows:

3.1.2 *fluid temperature, FT*—the temperature at which the fused mass has spread out in a nearly flat layer with a maximum height of 1.6 mm [ $1/16$  in.] as shown by the fifth cone, FT, in Fig. 1.

3.1.3 *hemispherical temperature, HT*—the temperature at which the cone has fused down to a hemispherical lump at which point the height is one-half the width of the base as shown by the fourth cone, HT, in Fig. 1.

3.1.4 *initial deformation temperature, IT*—the temperature at which the first rounding of the apex of the cone occurs. Shrinkage or warping of the cone ignored if the tip remains sharp. In Fig. 1, the first cone shown is an unheated one; the second cone, IT, is a typical cone at the initial deformation stage.

<sup>3</sup> The last approved version of this historical standard is referenced on www.astm.org.

\*A Summary of Changes section appears at the end of this standard

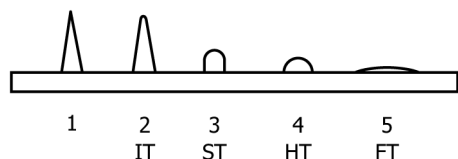

FIG. 1 Critical Temperature Points

3.1.5 *softening temperature, ST*—the temperature at which the cone has fused down to a spherical lump in which the height is equal to the width at the base as shown by the third cone, ST, in Fig. 1.

#### 4. Summary of Test Method

4.1 Coal or coke ash, prepared by prescribed methods, is mixed with a small amount of a dextrin solution to form a plastic mass. A cone mold is used to form triangular pyramids with the plastic mass, which are dried and mounted on a ceramic platform. The cones and platform are rapidly heated in an electric furnace to 400 °C [750 °F]. The cones and platform are then heated at a rate of 8 °C ± 3 °C [15 °F ± 5 °F]/min in a reducing (CO/CO<sub>2</sub>) atmosphere, or an oxidizing (air) atmosphere. The ash cones are carefully observed as they pass through certain defined stages of melting and flow.

#### 5. Significance and Use

5.1 The design of most coal combustion and coal conversion equipment anticipates that the ash either remain solid or assume some degree of fluidity, depending on the particular design. Ash fusibility temperatures help predict whether the ash will perform properly in the process for which the coal was chosen.

5.2 Ash fusibility temperature values are used in various equations to predict the slagging tendency of ashes.

#### 6. Apparatus

6.1 *Furnace*—An electric furnace conforming to the following requirements may be used:

6.1.1 Capable of maintaining a uniform temperature zone in which to heat the ash cones.

6.1.2 Capable of maintaining the desired atmosphere surrounding the cones during heating. The composition of the atmosphere, reducing or oxidizing, shall be maintained within the limits specified in Section 7. The desired atmosphere is to be obtained by means of gases introduced into the heating chamber. The furnace should be gas impervious.

6.1.3 Capable of regulation so that the rate of temperature rise shall be 8 °C ± 3 °C [15 °F ± 5 °F]/min.

6.1.4 Providing means of observing the ash cones during the heating. Observation on the same horizontal plane as the cone-support surface shall be possible.

6.2 *Cone Mold*—A commercially available cone mold, typically brass or made from a corrosion-resistant material with a low coefficient of friction, as shown in Fig. 2. The cone shall be 19 mm [¾ in.] in height and 6.4 mm [¼ in.] in width at each side of the base, which is an equilateral triangle. A steel spatula with a pointed tip, ground off to fit the cone depression in the mold, is suitable for removal of the ash cone.

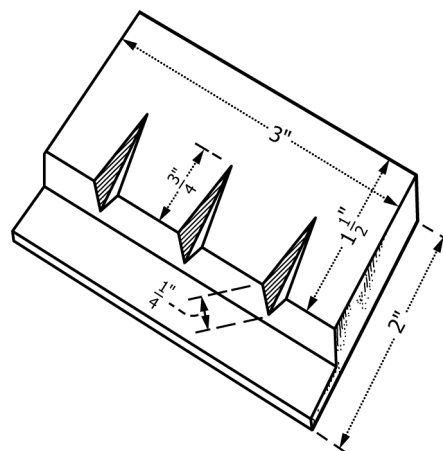

Inch-Pound Units, in.	SI Units, mm
¼	6.4
¾	19.1
1½	38.1
2	50.2
3	76.2

FIG. 2 Brass Cone Mold

6.3 *Refractory Tray Mold*—A mold with flat top and bottom surfaces to provide a refractory tray of suitable thickness to minimize warping. A sidemold not over 6.4 mm [¼ in.] high of any convenient shape, placed on an iron plate so that the top surface of the refractory mix can be struck off flat and parallel to the tray by means of a straightedge, is satisfactory. Legs not over 3 mm [⅛ in.] long may be provided on the corners of the cone tray by suitable holes bored in the iron base plate of the mold.

6.4 *Temperature Measuring Instrument*—A type R or S thermocouple of platinum and platinum-rhodium, protected from the furnace gases by a glazed porcelain sheath, shall be used with a display readable to better than 5.5 °C [10 °F]. The hot junction of the thermocouple shall touch the end of the sheath and shall be located in the center of the furnace and immediately to the rear of the cones. The thermocouple protective sheath shall be checked for cracks when there is difficulty in achieving the requirements outlined in Section 10.

#### 7. Reagents and Materials

7.1 *Ash-Cone Refractory Trays*—The ash cones shall be mounted on refractory trays. These trays are commercially available, or can be prepared using a mixture of equal parts by weight of kaolin and alumina. Materials conforming to the following requirements are to be used in preparing the refractory trays:

7.2 *Kaolin*—NF-grade powder passing a 75 µm (U.S.A. Standard No. 200) sieve.

7.3 *Aluminum Oxide*—Reagent-grade ignited powder passing a 150 µm (U.S.A. Standard No. 100) sieve.

7.4 *Dextrin Solution*—Clear, filtered (if necessary) 10 % solution of dextrin containing 0.1 % salicylic acid as a preservative.