



Designation: D2156 – 09 (Reapproved 2024)

Standard Test Method for Smoke Density in Flue Gases from Burning Distillate Fuels¹

This standard is issued under the fixed designation D2156; the number immediately following the designation indicates the year of original adoption or, in the case of revision, the year of last revision. A number in parentheses indicates the year of last reapproval. A superscript epsilon (ϵ) indicates an editorial change since the last revision or reapproval.

This standard has been approved for use by agencies of the U.S. Department of Defense.

1. Scope

1.1 This test method covers the evaluation of smoke density in the flue gases from burning distillate fuels. It is intended primarily for use with home heating equipment burning kerosine or heating oils. It can be used in the laboratory or in the field to compare fuels for clean burning or to compare heating equipment.

1.2 The values stated in SI units are to be regarded as standard. No other units of measurement are included in this standard.

1.2.1 Arbitrary and relative units are also used.

1.3 *This standard does not purport to address all of the safety concerns, if any, associated with its use. It is the responsibility of the user of this standard to establish appropriate safety, health, and environmental practices and determine the applicability of regulatory limitations prior to use.*

1.4 *This international standard was developed in accordance with internationally recognized principles on standardization established in the Decision on Principles for the Development of International Standards, Guides and Recommendations issued by the World Trade Organization Technical Barriers to Trade (TBT) Committee.*

2. Referenced Documents

2.1 *ASTM Standards:*²

E97 Method of Test for Directional Reflectance Factor, 45-Deg 0-Deg, of Opaque Specimens by Broad-Band Filter Reflectometry (Withdrawn 1991)³

3. Terminology

3.1 *Definitions of Terms Specific to This Standard:*

¹ This method is under the jurisdiction of ASTM Committee D02 on Petroleum Products, Liquid Fuels, and Lubricants and is the direct responsibility of Subcommittee D02.E0 on Burner, Diesel and Non-Aviation Gas Turbine Fuels.

Current edition approved March 1, 2024. Published April 2024. Originally approved in 1963. Last previous edition approved in 2018 as D2156 – 09 (2018). DOI: 10.1520/D2156-09R24.

² For referenced ASTM standards, visit the ASTM website, www.astm.org, or contact ASTM Customer Service at service@astm.org. For *Annual Book of ASTM Standards* volume information, refer to the standard's Document Summary page on the ASTM website.

³ The last approved version of this historical standard is referenced on www.astm.org.

3.1.1 *smoke spot number, n*—the number of the spot on the standard scale most closely matching the color (or shade) of the test spot.

4. Summary of Test Method

4.1 A test smoke spot is obtained by pulling a fixed volume of flue gas through a fixed area of standard filter paper. The color (or shade) of the spot thus produced is visually matched with a standard scale, and the smoke density is expressed as a “smoke spot number.”

5. Significance and Use

5.1 This test method provides a means of controlling smoke production in home heating equipment to an acceptable level. Excessive smoke density adversely affects efficiency by heat-exchanger fouling.

5.2 The range of smoke densities covered by this test method is that which has been found particularly pertinent to home-heating application. It is more sensitive to small amounts of smoke than several other smoke tests as indicated in the following comparison:

Smoke Spot Number	Icham, percent Transmission	Ringelman Smoke Number
0	100	0
2	95	0
4	80	0
6	54	0
8	18	0
9	0	0
9	0	0 to 5

6. Apparatus

6.1 *Sampling Device*—A suitable device providing a total flue gas sample volume of 36.9 L \pm 1.65 L at 16 °C, 101 kPa for each 645 mm² effective surface area of filter paper shall be employed. The sampling device and connections shall be of such construction that the total travel of flue gas sample from flue to filter paper shall not exceed 410 mm. The device shall provide for cooling the sample below the charring temperature for the filter paper but not below the dew point of the sample. Suitable laboratory and portable field service equipment is illustrated in Fig. 1 and Fig. 2.

6.2 *Smoke Scale*—The smoke scale required consists of ten spots numbered consecutively from 0 to 9, ranging in equal

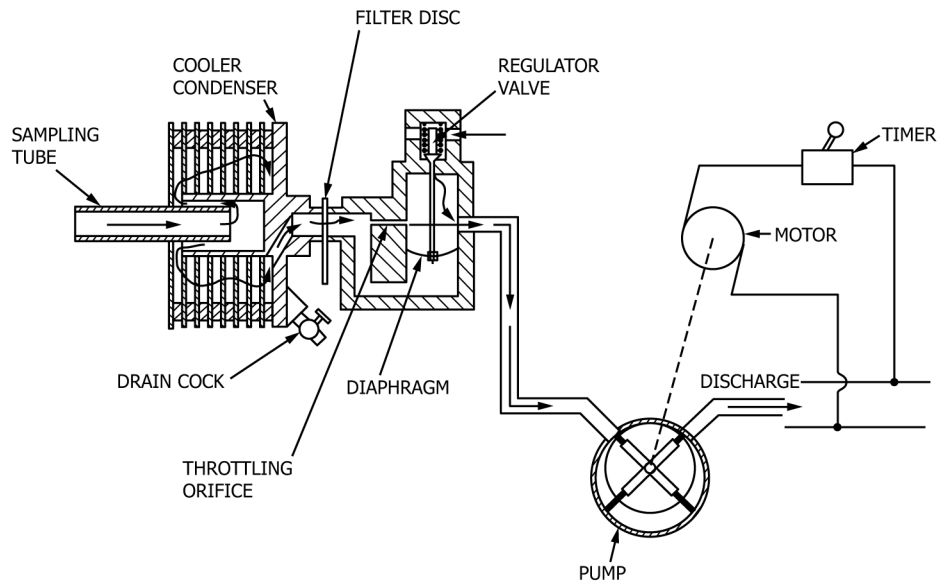

FIG. 1 Laboratory Type Smoke Meter

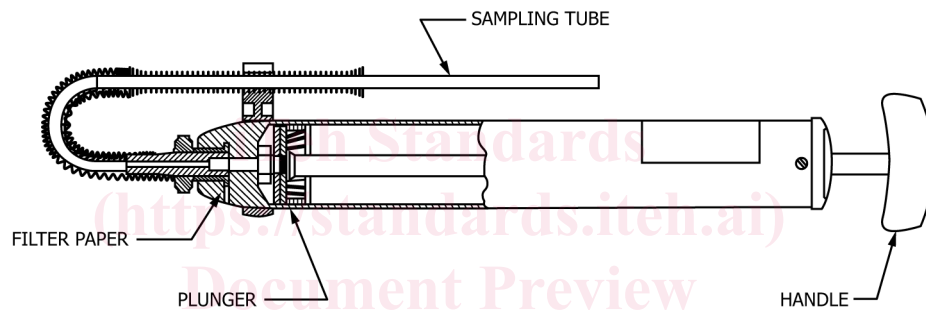

FIG. 2 Field Service Type Smoke Tester

photometric steps from white through neutral shades of gray to black, imprinted or otherwise processed on white paper or plastic stock having a surface reflectance of between 82.5 % and 87.5 % 45°, 0° daylight luminous directional reflectance in accordance with Test Method E97. The smoke scale spot number is defined as the reduction (due to smoke) in reflected incident light divided by 10. Thus, the first spot, which is the color of the unimprinted scale, will be No. 0, since in the case of this spot there will be no reduction in reflected incident light directed thereon. The last spot, however, is very dark, reflecting only 10 % of the incident light directed thereon; thus in this case the reduction in reflected incident light is 90 %, which gives to this darkest spot the No. 9. Intermediate spot numbers are similarly established. Limits of permissible reflectance variation of any smoke scale spot shall not exceed ± 3 % relative reflectance (Note 1 and Note 2).

NOTE 1—Such smoke scales are sufficiently accurate for field use and for many laboratory smoke testing applications. However, specially calibrated scales (known as certified smoke scales) will sometimes be required. A certified smoke scale is obtained by individually calibrating each smoke spot of a normal smoke scale.

NOTE 2—Where the smoke scale is protected with a plastic or transparent cover the construction employed shall be such that when the smoke spot on the filter paper is viewed for matching with the number spots on the smoke scale, both shall be visible through the same thickness and number of sheets of transparent protective cover.

7. Materials

7.1 *Test Filter Paper*, made from white filter paper stock having a surface reflectance of 82.5 % to 87.5 % 45°, 0° daylight luminous directional reflectance, in accordance with the Test Method E97. When clean air at standard conditions is drawn through clean filter paper at a rate of 476 L/s·m² effective surface area of filter paper, the pressure drop across the filter paper falls between limits of 1.7 kPa and 8.4 kPa.

8. Procedure

8.1 The sampling procedure used is critical. Therefore, the procedure recommended by the equipment manufacturer shall be rigidly followed.

8.2 Use a clean, dry, sampling device. If a hand sampler is used, warm it above room temperature to prevent condensation on the filter paper. (This can usually be done conveniently by placing the sampler on the boiler or furnace to be tested.)

8.3 Insert filter paper in the sampler and tighten the filter paper holder. Connect the sampling device to the flue gas probe. When taking smoke measurements in the flue pipe, position the end of the sampling probe at the center line of the flue pipe.