



Designation: D6318 – 24

# Standard Practice for Calibrating a Fathometer Using a Bar Check Method<sup>1</sup>

This standard is issued under the fixed designation D6318; the number immediately following the designation indicates the year of original adoption or, in the case of revision, the year of last revision. A number in parentheses indicates the year of last reapproval. A superscript epsilon ( $\epsilon$ ) indicates an editorial change since the last revision or reapproval.

## 1. Scope

1.1 This practice provides the user with procedures used in manually calibrating the fathometer or electronic depth sounder. This narrative describes calibration terminology, describes acceptable environmental conditions for calibration, and describes the calibration procedures.

1.2 The references cited contain useful information in the construction and the correct operation of the calibration equipment.

1.3 Any references cited in this narrative to specific products or brand names are made for information only, and is intended to be descriptive, but not restrictive, of products that will perform satisfactorily.

1.4 The values stated in inch-pound units are to be regarded as standard. The values given in parentheses are mathematical conversions to SI units that are provided for information only and are not considered standard.

1.5 *This standard does not purport to address all of the safety concerns, if any, associated with its use. It is the responsibility of the user of this standard to establish appropriate safety, health, and environmental practices and determine the applicability of regulatory limitations prior to use.*

1.6 *This international standard was developed in accordance with internationally recognized principles on standardization established in the Decision on Principles for the Development of International Standards, Guides and Recommendations issued by the World Trade Organization Technical Barriers to Trade (TBT) Committee.*

## 2. Referenced Documents

2.1 *ASTM Standards:*<sup>2</sup>

[D1129 Terminology Relating to Water](#)

<sup>1</sup> This practice is under the jurisdiction of ASTM Committee D19 on Water and is the direct responsibility of Subcommittee D19.07 on Sediments, Geomorphology, and Open-Channel Flow.

Current edition approved April 1, 2024. Published April 2024. Originally approved in 1998. Last previous edition approved in 2014 as D6318 – 03 (2014) which was withdrawn July 2023 and reinstated in April 2024. DOI: 10.1520/D6318-24.

<sup>2</sup> For referenced ASTM standards, visit the ASTM website, [www.astm.org](http://www.astm.org), or contact ASTM Customer Service at [service@astm.org](mailto:service@astm.org). For *Annual Book of ASTM Standards* volume information, refer to the standard's Document Summary page on the ASTM website.

[D5073 Practice for Depth Measurement of Surface Water](#)

## 3. Terminology

3.1 *Definitions*—Refer to Terminology [D1129](#) for terms used in this guide.

3.2 *Definitions of Terms Specific to This Standard:*

3.2.1 *bar, n*—a section of metallic channel, I-beam, T-beam, pipe, plate, or ball that will reflect sound waves produced by a fathometer.

3.2.2 *bar-check, n*—a method for calibrating a fathometer by setting a sound or acoustic reflector (bar) below a survey vessel to a known depth below a sounding transducer.

3.2.3 *draft (transducer draft), n*—the vertical distance from the bottom of the transducer to the surface of the water.

3.2.4 *fathometer, n*—An electronic device for registering depths of water by measuring the time required for the transmission and reflection of sound waves between a sonic transducer and the lake or river bottom.

3.2.5 *sound, n*—to determine the depth of water.

3.2.6 *sounding scroll, n*—the chart record of an underwater cross section or profile of the bottom.

3.2.7 *transducer, n*—a device for translating electrical energy to acoustical energy and acoustical energy back to electrical energy.

## 4. Significance and Use

4.1 The accuracy of depth measurements made by a fathometer or echo sounder requires a number of corrections because of the variability of sound or acoustic velocity in water with changes in temperature, salinity, and depth of water. In addition instability of the equipment can also result in significant errors. For additional information see Practice [D5073](#).

4.2 Calibration of echo sounding instruments is absolutely critical in assuring the adequacy of depth measurements. When an echo sounder has been accurately calibrated, any observed (recorded) depth can be related to the true depth of water. Since the intended purpose of echo sounding is to measure the “true” depth, an independent “true” reference must be used.

4.3 A bar-check is the most wide-spread, easiest to construct, and most economical mechanical method to determine corrections for instrument and velocity errors.

4.4 This procedure explains the calibration of a fathometer or electronic depth sounder using a bar-check.

4.5 Bar-checking techniques and equipment are general in nature and may need to be modified for use in specific field conditions.

### 5. Apparatus

5.1 The device used for bar-checking must be a sound-reflecting surface that can be lowered to a known depth below the transducer of the survey vessel. See Fig. 1. These sounding-reflecting surfaces (or sounding targets) can be a bar made out of a section of metallic I-beam or T-beam, pipe, a rectangular section of sheet metal, or a section of metal screen.

5.2 Bars used in depths greater than 30 ft (10 m) should be at least 9 in. (23 cm) wide. The dimensions of the target depend on the type of survey vessel, location of the transducer, and the depth range to be covered during the survey. Usually, the length of the bar is equal to the beam or width for small survey vessels. For larger vessels, a spherical metal ball or steel plate is lowered through a well in the hull.

5.3 The weight of the bar will be dependent on the type of currents experienced, typical project depths, and beam of the vessel. Typical weights range from 40 lb to 100 lb (20 kg to 50 kg). In deep water areas with large currents, a heavy bar is essential because subsurface currents will pull a bar from the transducer's vertical plane. On small, shallow inland or protected bodies of water, a lighter weight may be used provided the bar can be maintained directly beneath the transducer.

5.4 The lines used for lowering the bar should be made of flexible steel wire or chain. They must be easy to handle and must not stretch. In addition, they should be at least 100 ft long

with either easily visible markings at every 10 ft starting at the top of the bar or carried on a calibrated reel. The bar check suspension lines must be periodically checked to ensure the accuracy and stability of the graduated marks on the line

### 6. Condition Requirements

6.1 The preferred environmental conditions for bar-checking are calm water, wind velocity less than 5 mph, and depths less than 100 ft. Reasonable results, however, can be obtained during wind velocities between 5 mph and 15 mph. But when wind velocities are greater than 15 mph and depths greater than 100 ft, some error will exist in the soundings.

6.2 Bar checks should always be made when and where water conditions are calmest; observations taken during rough water conditions or when differential current causes the bar to be displaced from a position vertically below the transducer are subject to unacceptable magnitudes of error.

6.3 For best results where salinity and temperature of the water are unknown, the fathometer should be calibrated before the start, at midday and at the end of each day's work to check the accuracy of the soundings. However, if stable water conditions are known to exist, it is possible to limit the number of bar-checks to one per day before the start of the work.

6.4 A survey vessel operating in exposed rough water or windy conditions should run to a protected area for the bar check. Bar checks, however, should not be made in areas where salinity, temperatures, and suspended sediment concentrations vary significantly from those at the area to be surveyed.

### 7. Bar-check Procedure

7.1 Turn the fathometer on about 10 min before beginning the calibration process to allow the machine to warm up.

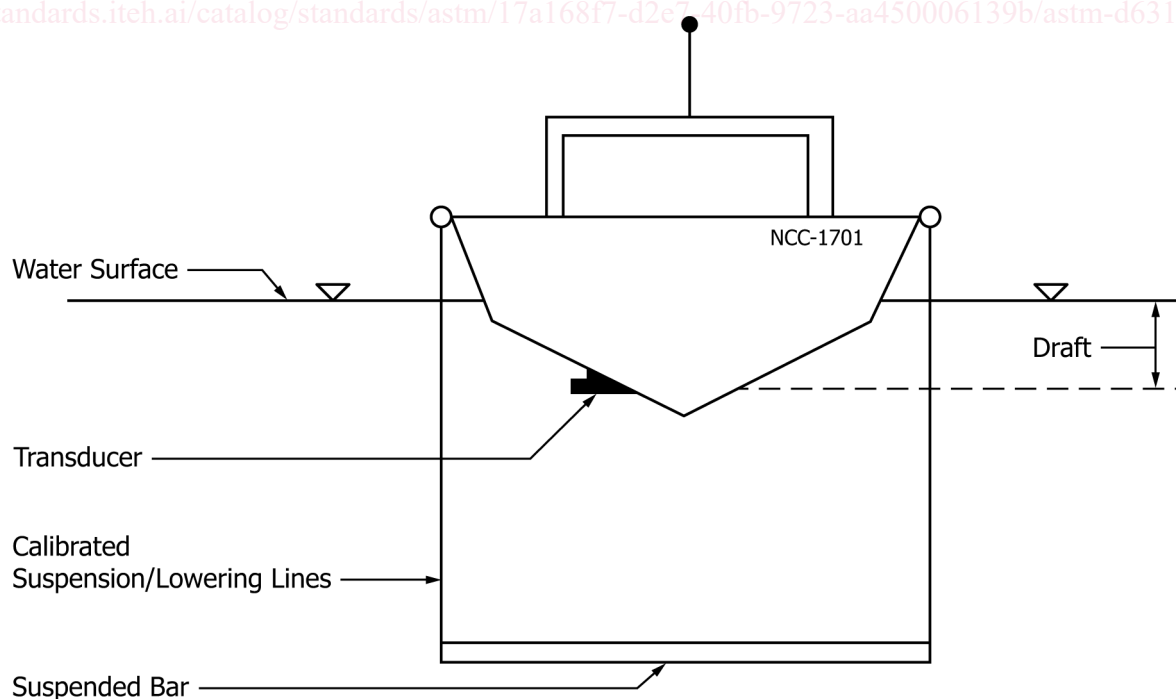

FIG. 1 Calibration Bar Apparatus