



Designation: C1774 – 24

# Standard Guide for Thermal Performance Testing of Cryogenic Insulation Systems<sup>1</sup>

This standard is issued under the fixed designation C1774; the number immediately following the designation indicates the year of original adoption or, in the case of revision, the year of last revision. A number in parentheses indicates the year of last reapproval. A superscript epsilon ( $\epsilon$ ) indicates an editorial change since the last revision or reapproval.

## 1. Scope

1.1 This guide provides information for the laboratory measurement of the steady-state thermal transmission properties and heat flux of thermal insulation systems under cryogenic conditions. Thermal insulation systems may be composed of one or more materials that may be homogeneous or non-homogeneous; flat, cylindrical, or spherical; at boundary conditions from near absolute zero or 4 K up to 400 K; and in environments from high vacuum to an ambient pressure of air or residual gas. The testing approaches presented as part of this guide are distinct from, and yet complementary to, other ASTM thermal test methods including C177, C518, and C335. A key aspect of this guide is the notion of an insulation system, not an insulation material. Under the practical use environment of most cryogenic applications even a single-material system can still be a complex insulation system (1-3).<sup>2</sup> To determine the inherent thermal properties of insulation materials, the standard test methods as cited in this guide should be consulted.

1.2 The function of most cryogenic thermal insulation systems used in these applications is to maintain large temperature differences thereby providing high levels of thermal insulating performance. The combination of warm and cold boundary temperatures can be any two temperatures in the range of near 0 K to 400 K. Cold boundary temperatures typically range from 4 K to 100 K, but can be much higher such as 300 K. Warm boundary temperatures typically range from 250 K to 400 K, but can be much lower such as 40 K. Large temperature differences up to 300 K are typical. Testing for thermal performance at large temperature differences with one boundary at cryogenic temperature is typical and representative of most applications. Thermal performance as a function of temperature can also be evaluated or calculated in

accordance with Practices C1058 or C1045 when sufficient information on the temperature profile and physical modeling are available.

1.3 The range of residual gas pressures for this Guide is from  $10^{-7}$  torr to  $10^{+3}$  torr ( $1.33^{-5}$  Pa to 133 kPa) with different purge gases as required. Corresponding to the applications in cryogenic systems, three sub-ranges of vacuum are also defined: High Vacuum (HV) from  $<10^{-6}$  torr to  $10^{-3}$  torr ( $1.333^{-4}$  Pa to 0.133 Pa) [free molecular regime], Soft Vacuum (SV) from  $10^{-2}$  torr to 10 torr (from 1.33 Pa to 1,333 Pa) [transition regime], No Vacuum (NV) from 100 torr to 1000 torr (13.3 kPa to 133 kPa) [continuum regime].

1.4 Thermal performance can vary by four orders of magnitude over the entire vacuum pressure range. Effective thermal conductivities can range from 0.010 mW/m-K to 100 mW/m-K. The primary governing factor in thermal performance is the pressure of the test environment. High vacuum insulation systems are often in the range from 0.05 mW/m-K to 2 mW/m-K while non-vacuum systems are typically in the range from 10 mW/m-K to 30 mW/m-K. Soft vacuum systems are generally between these two extremes (4). Of particular demand is the very low thermal conductivity (very high thermal resistance) range in sub-ambient temperature environments. For example, careful delineation of test results in the range of 0.01 mW/m-K to 1 mW/m-K (from R-value 14,400 to R-value 144) is required as a matter of normal engineering applications for many cryogenic insulation systems (5-7). The application of effective thermal conductivity values to multilayer insulation (MLI) systems and other combinations of diverse materials, because they are highly anisotropic and specialized, must be done with due caution and full provision of supporting technical information (8). The use of heat flux ( $W/m^2$ ) is, in general, more suitable for reporting the thermal performance of MLI systems (9-11).

1.5 This guide covers different approaches for thermal performance measurement in sub-ambient temperature environments. The test apparatuses (apparatus) are divided into two categories: boiloff calorimetry and electrical power. Both absolute and comparative apparatuses are included.

1.6 This guide sets forth the general design requirements necessary to construct and operate a satisfactory test apparatus.

<sup>1</sup> This guide is under the jurisdiction of ASTM Committee C16 on Thermal Insulation and is the direct responsibility of Subcommittee C16.30 on Thermal Measurement.

Current edition approved March 15, 2024. Published April 2024. Originally approved in 2013. Last previous edition approved in 2019 as C1774 – 13 (2019). DOI: 10.1520/C1774-24.

<sup>2</sup> The boldface numbers in parentheses refer to the list of references at the end of this standard.

A wide variety of apparatus constructions, test conditions, and operating conditions are covered. Detailed designs are not given but must be developed within the constraints of the general requirements. Examples of different cryogenic test apparatuses are found in the literature (12). These apparatuses include boiloff types (13-17) as well as electrical types (18-21).

1.7 These testing approaches are applicable to the measurement of a wide variety of specimens, ranging from opaque solids to porous or transparent materials, and a wide range of environmental conditions including measurements conducted at extremes of temperature and with various gases and over a range of pressures. Of particular importance is the ability to test highly anisotropic materials and systems such as multilayer insulation (MLI) systems (22-25). Other test methods are limited in this regard and do not cover the testing of MLI and other layered systems under the extreme cryogenic and vacuum conditions that are typical for these systems.

1.8 In order to ensure the level of precision and accuracy expected, users applying this standard must possess a working knowledge of the requirements of thermal measurements and testing practice and of the practical application of heat transfer theory relating to thermal insulation materials and systems. Detailed operating procedures, including design schematics and electrical drawings, should be available for each apparatus to ensure that tests are in accordance with this Guide. In addition, automated data collecting and handling systems connected to the apparatus must be verified as to their accuracy. Verification can be done by calibration and comparing data sets, which have known results associated with them, using computer models.

1.9 It is impractical to establish all details of design and construction of thermal insulation test equipment and to provide procedures covering all contingencies associated with the measurement of heat flow, extremely delicate thermal balances, high vacuum, temperature measurements, and general testing practices. The user may also find it necessary, when repairing or modifying the apparatus, to become a designer or builder, or both, on whom the demands for fundamental understanding and careful experimental technique are even greater. The test methodologies given here are for practical use and adaptation as well as to enable future development of improved equipment or procedures.

1.10 This guide does not specify all details necessary for the operation of the apparatus. Decisions on sampling, specimen selection, preconditioning, specimen mounting and positioning, the choice of test conditions, and the evaluation of test data shall follow applicable ASTM Test Methods, Guides, Practices or Product Specifications or governmental regulations. If no applicable standard exists, sound engineering judgment that reflects accepted heat transfer principles must be used and documented.

1.11 This guide allows a wide range of apparatus design and design accuracy to be used in order to satisfy the requirements of specific measurement problems. Compliance with a further specified test method should include a report with a discussion of the significant error factors involved as well the uncertainty of each reported variable.

1.12 The values stated in SI units are to be regarded as the standard. The values given in parentheses are for information only. Either SI or Imperial units may be used in the report, unless otherwise specified.

1.13 Safety precautions including normal handling and usage practices for the cryogen of use. Prior to operation of the apparatus with any potentially hazardous cryogen or fluid, a complete review of the design, construction, and installation of all systems shall be conducted. Safety practices and procedures regarding handling of hazardous fluids have been extensively developed and proven through many years of use. For systems containing hydrogen, particular attention shall be given to ensure the following precautions are addressed: (1) adequate ventilation in the test area, (2) prevention of leaks, (3) elimination of ignition sources, (4) fail safe design, and (5) redundancy provisions for fluid fill and vent lines. *This standard does not purport to address all of the safety concerns, if any, associated with its use. It is the responsibility of the user of this standard to establish appropriate safety, health, and environmental practices and determine the applicability of regulatory limitations prior to use.*

1.14 Major sections within this standard are arranged as follows:

	Section
Scope	1
Referenced Documents	2
Terminology	3
Summary of Test Methods	4
Significance and Use	5
Apparatus	6
Test Specimens and Preparation	7
Procedure	8
Calculation of Results	9
Report	10
Keywords	11
Annexes	
Cylindrical Boiloff Calorimeter (Absolute)	Annex A1
Cylindrical Boiloff Calorimeter (Comparative)	Annex A2
Flat Plate Boiloff Calorimeter (Absolute)	Annex A3
Flat Plate Boiloff Calorimeter (Comparative)	Annex A4
Electrical Power Cryostat Apparatus (Cryogen)	Annex A5
Electrical Power Cryostat Apparatus (Cryocooler)	Annex A6
Appendix	
Rationale	Appendix X1
References	

1.15 *This international standard was developed in accordance with internationally recognized principles on standardization established in the Decision on Principles for the Development of International Standards, Guides and Recommendations issued by the World Trade Organization Technical Barriers to Trade (TBT) Committee.*

## 2. Referenced Documents

### 2.1 ASTM Standards:<sup>3</sup>

C167 Test Methods for Thickness and Density of Blanket or Batt Thermal Insulations

C168 Terminology Relating to Thermal Insulation

C177 Test Method for Steady-State Heat Flux Measurements and Thermal Transmission Properties by Means of

<sup>3</sup> For referenced ASTM standards, visit the ASTM website, [www.astm.org](http://www.astm.org), or contact ASTM Customer Service at [service@astm.org](mailto:service@astm.org). For *Annual Book of ASTM Standards* volume information, refer to the standard's Document Summary page on the ASTM website.

- the Guarded-Hot-Plate Apparatus
- C335** Test Method for Steady-State Heat Transfer Properties of Pipe Insulation
- C518** Test Method for Steady-State Thermal Transmission Properties by Means of the Heat Flow Meter Apparatus
- C520** Test Methods for Density of Granular Loose Fill Insulations
- C534** Specification for Preformed Flexible Elastomeric Cellular Thermal Insulation in Sheet and Tubular Form
- C549** Specification for Perlite Loose Fill Insulation
- C552** Specification for Cellular Glass Thermal Insulation
- C578** Specification for Rigid, Cellular Polystyrene Thermal Insulation
- C591** Specification for Unfaced Preformed Rigid Cellular Polyisocyanurate Thermal Insulation
- C680** Practice for Estimate of the Heat Gain or Loss and the Surface Temperatures of Insulated Flat, Cylindrical, and Spherical Systems by Use of Computer Programs
- C740** Guide for Evacuated Reflective Insulation In Cryogenic Service
- C870** Practice for Conditioning of Thermal Insulating Materials
- C1029** Specification for Spray-Applied Rigid Cellular Polyurethane Thermal Insulation
- C1045** Practice for Calculating Thermal Transmission Properties Under Steady-State Conditions
- C1058** Practice for Selecting Temperatures for Evaluating and Reporting Thermal Properties of Thermal Insulation
- C1482** Specification for Polyimide Flexible Cellular Thermal and Sound Absorbing Insulation
- C1484** Specification for Vacuum Insulation Panels
- C1594** Specification for Polyimide Rigid Cellular Thermal Insulation
- C1667** Test Method for Using Heat Flow Meter Apparatus to Measure the Center-of-Panel Thermal Transmission Properties of Vacuum Insulation Panels
- C1728** Specification for Flexible Aerogel Insulation
- E230** Specification for Temperature-Electromotive Force (emf) Tables for Standardized Thermocouples
- E408** Test Methods for Total Normal Emittance of Surfaces Using Inspection-Meter Techniques
- E691** Practice for Conducting an Interlaboratory Study to Determine the Precision of a Test Method
- 2.2 *ISO Standard*.<sup>4</sup>
- ISO 21014** Cryogenic Vessels: Cryogenic Insulation Performance

### 3. Terminology

3.1 *Definitions*—Terminology of standards **C168**, **C680**, and **C1045** applies to the terms used in this standard unless otherwise noted. Properties based on specimens tested under the conditions specified may not be representative of the installed performance if the end use conditions differ substantially from the test conditions. The temperature dependences of the thermal performance of a given insulation test specimen,

particularly those at large temperature differentials that are common to most cryogenic insulation systems, are generally expected to be significant and non-linear in nature. For details on testing or analysis in the thermal characterization of a specific material, Practice **C1045**, Section 6, Determination of the Thermal Conductivity Relationship for a Temperature Range, should be consulted.

#### 3.2 *Definitions*:

3.2.1 *cryogenic insulation systems*—encompass a wide range of material combinations and thermal performance levels. Examples of the effective thermal conductivity of different systems and the widely varying thermal performance ranges are shown in **Fig. 1**.

3.2.2 *insulation test specimen*—an insulation test specimen is composed of one or more materials, homogeneous or non-homogeneous, for which thermal transmission properties through the thickness of the system are to be measured under sub-ambient conditions.

3.2.2.1 *Discussion*—An insulation test specimen may consist of a single material, one type of material in several discrete elements, or a number of different materials working in a specialized design configuration. In reality, a test specimen is always a system, either a single material (with or without inclusion of a gas) or a combination of materials in different forms. Forms of insulation test specimens may be bulk-fill, powder, blanket, layered, clam-shell, panels, monoliths, or other type configurations. Examples of materials include foams (closed cell or open cell), fibrous insulation products, aerogels (blankets or bulk-fill or packaged), multilayer insulation systems, clam shells of foams of cellular glass, composite panels, polymeric composites, or any number of bulk-fill materials such as perlite powder and glass bubbles.

3.2.3 *multilayer insulation (MLI)*—insulation systems composed of multiple radiation shields physically separated to reduce conductive heat transfer. The radiation shields are thin plastic membranes (usually polyester or polyimide films) coated on one or both sides with a low-emittance, vapor-deposited metal (usually aluminum, gold, or silver), or thin metal foil membranes. Separation of the shields can be accomplished by (1) alternating thin layers of low-density, low-conductivity materials such as woven fabric net, fibrous paper, powder insulation, or sliced foam spacers within the radiation shields; (2) bonding low-density, low conductivity filaments to one side of the radiation shields; (3) mechanically crinkling, dimpling, or embossing the radiation shields themselves; (4) attaching mechanical spacers; or (5) levitating the radiation shields with static or magnetic forces. For some techniques, the radiation shields are commonly metalized on one side only to achieve minimum conductive heat transfer. Guide **C740** provides further information on MLI materials, designs, and performance characteristics. Test Methods **E408** gives information on emissivity testing of the reflective materials used in constructing MLI systems.

#### 3.3 *Definitions of Terms Specific to This Standard*:

3.3.1 *cold boundary temperature (CBT)*—the cold boundary temperature is defined as the cold temperature imposed on cold-side surface of the insulation material by the cold mass.

<sup>4</sup> Available from American National Standards Institute (ANSI), 25 W. 43rd St., 4th Floor, New York, NY 10036, <http://www.ansi.org>.

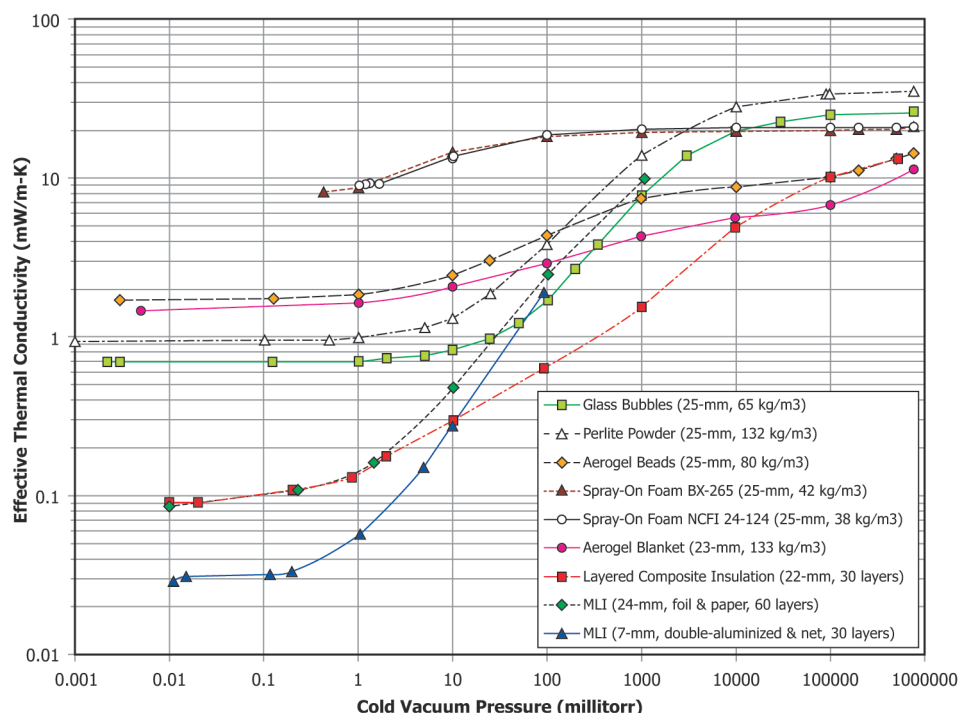

The boundary temperatures are approximately 78 K and 293 K, the residual gas is nitrogen, and the total thicknesses are typically 25-mm (3).

FIG. 1 Examples of the Variation of Effective Thermal Conductivity ( $k_e$ ) with Cold Vacuum Pressure are Shown for Different Cryogenic Insulation Systems

The cold mass may be cooled by a cryogen or a cryocooler. If a cryocooler is used, *CBT* will be derived from the net cold boundary power provided to the cold mass. The *CBT* is reported with both the effective thermal conductivity and heat flux measurements. *CBT* in SI units: K.

3.3.2 *cold vacuum pressure (CVP)*—the cold vacuum pressure is defined as the steady-state vacuum pressure level within the insulation system achieved after cooldown. The *CVP* can be any pressure from high vacuum to no vacuum, with or without a residual gas. The *CVP* and residual gas composition is reported with both the effective thermal conductivity and heat flux measurements. *CVP* in SI units: Pa; in conventional units: millitorr; one millitorr = 0.1333 Pa.

3.3.3 *effective thermal conductivity ( $k_e$ )*—the thermal conductivity through the total thickness of the insulation test specimen between the reported boundary temperatures and in a specified environment (mW/m-K). The insulation test specimen may be one material, homogeneous non-homogeneous, or a combination of materials. As this guide addresses many different materials and a wide spectrum of low-temperature applications, and as the use of thermal performance values stated in units of thermal conductivity is a widely used practice in cryogenic engineering design and development activities, a full explanation of such terms is given herein. The use of  $k_e$  is often essential for informing decisions between different design approaches to insulation systems such as vacuum-jacketed versus ambient pressure or MLI versus bulk-fill powder. The  $k_e$  values are also used for product development, comparison of similar systems, gross comparison of widely different systems, and preliminary design calculations for first order thermal

performance estimates. The thickness parameter that is part of  $k_e$  is also important for understanding volumetric limitations and for assessing overall weight and thermal mass properties of the system in both steady-state and transient operations. Any scaling or extrapolation of  $k_e$  data is generally not recommended, especially in the case of MLI type systems. However, if any scaling is performed it should be done with caution and within the bounds of good engineering judgment (26). In scaling or other such comparisons the user must keep in mind the differences in the magnitude of thermal performance, environment, boundary temperatures, thickness variations, and mechanical nature of the materials used. Note also that thermal conductance can be directly calculated based on heat flux and geometry.

3.3.3.1 *Discussion*—In accordance with C168, thermal conductivity ( $\lambda$ ) is for a homogeneous material with a single mode of heat transfer and is generally independent of thickness. Apparent thermal conductivity ( $\lambda_a$ ) is for a material that exhibits thermal transmission by several modes of heat transfer that often results in property variations with thickness, surface emittance, cellular or interstitial content, etc. Use of the “apparent” modifier must always be accompanied by the conditions of the measurement. These usage issues are addressed for homogeneous materials; the property variations, both in number and magnitude, are often even more pronounced for the case of cryogenic-vacuum testing and the low density materials of main interest.

3.3.3.2 *Discussion*—Practice C1045, Appendix X3, develops definitions and calculations for thermal conductivity variations with mean temperature. The purpose is to clarify the

differences between analysis of data at large temperature differences and those taken at small temperature differences. Equations for mean thermal conductivity ( $\lambda_m$ ) and thermal conductivity at the mean temperature [ $\lambda(T_m)$ ] are provided. However, this section points out that the practice only works for thermal transmission properties that show a gradual change with temperature and that it may not work for the following cases: (1) onset of convection, (2) abrupt change in phase of an insulation component such as a condensable gas, and (3) heat flow anomalies found in reflective insulations. Any of these cases are typically found in cryogenic insulation systems. Therefore, the use of  $\lambda_m$  is different from the  $\lambda_a$  defined in C168, even though both are considering large temperature differences.

3.3.3.3 *Discussion*—Practice C1058 gives information on reporting thermal properties using mean temperatures including the issues of testing closed-cell foams. This standard also provides guidance on the selection of temperature differences to be used in testing.

3.3.4 *heat flow rate (Q)*—quantity of heat energy transferred to or from a system in a unit of time (W).

3.3.5 *heat flux (q)*—heat flow rate, under steady-state conditions, through a unit area, in a direction perpendicular to the plane of the thermal insulation system ( $\text{W}/\text{m}^2$ ). A mean area must be calculated for any test geometry: cylindrical or spherical.

3.3.6 *high vacuum (HV)*—residual gas pressure from  $<10^{-7}$  torr to  $10^{-3}$  torr ( $<1.333 \times 10^{-5}$  Pa to 0.133 Pa) [free molecular regime].

3.3.7 *no vacuum (NV)*—residual gas pressure from 100 torr to 1000 torr (13.3 kPa to 133 kPa) [continuum, or viscous, regime]; 1 atmosphere pressure = 101.3 kPa = 760 torr.

3.3.8 *soft vacuum (SV)*—residual gas pressure from  $10^{-2}$  torr to 10 torr (1.33 Pa to 1333 Pa) [transition, or mixed mode, regime].

3.3.9 *system thermal conductivity ( $k_s$ )*—the thermal conductivity through the total thickness of the insulation test specimen and all ancillary elements such as packaging, supports, getter packages, enclosures, etc. ( $\text{mW}/\text{m}\cdot\text{K}$ ) (27, 28). As with  $k_e$ , the values of  $k_s$  must always be linked with the reported warm and cold boundary temperatures and the specific test environment.

3.3.9.1 *Discussion*—Specification C1484 defines an effective thermal resistance for vacuum insulation panels. This effective R-value is for the total system including all packaging elements and edge heat flow effects and is distinctly separate from the apparent thermal resistivity of the vacuum panel which is taken as the intrinsic center-of-panel thermal resistivity. Similarly, with many cryogenic-vacuum insulation systems, a main interest is the effective thermal conductivity through a complex of one or more materials ( $k_e$ ) as well as the system thermal conductivity ( $k_s$ ) of a total system as it would be used in application.

3.3.10 *warm boundary temperature (WBT)*—the warm boundary temperature is defined as the warm temperature imposed on the warm-side surface of the insulation material by the warm mass. The warm mass may be heated by an electrical heater, liquid bath heat exchanger, ambient environment, or

other means. The WBT could also be further developed from consideration of other types of boundary conditions such as convection or applied power or heat flux. The WBT is reported with both the effective thermal conductivity and heat flux measurements. WBT in SI units: K.

3.3.11 *warm vacuum pressure (WVP)*—the warm vacuum pressure is defined as the vacuum level within the insulation system before cooldown. The WVP is usually considered to be vacuum level at ambient temperature but may also be given as the vacuum level at some elevated temperature prescribed as part of a heating/bake-out step prior to evacuation. WVP in SI units: Pa; in Imperial units: torr; 1 torr = 133.3 kPa; 1 millitorr = 0.1333 Pa.

#### 3.4 Symbols and Units:

3.4.1  $A$ —area of test specimen,  $\text{m}^2$

3.4.2  $A_e$ —effective heat transfer area,  $\text{m}^2$

3.4.3  $d_e$ —effective heat transfer diameter (for flat plate specimens), m

3.4.4  $E$ —voltage, V

3.4.5  $h_{fg}$ —heat of vaporization, J/g

3.4.6  $I$ —current, A

3.4.7  $L$ —length of test specimen, m

3.4.8  $L_e$ —effective heat transfer length (for cylindrical specimens), m

3.4.9  $Q_{loss}$ —heater power loss, W

3.4.10  $r_o$ —outer radius of insulation, m

3.4.11  $r_i$ —inner radius of insulation, m

3.4.12  $\Delta T$ —temperature difference (WBT – CBT), K

3.4.13  $V_g$ —volumetric flow rate of a gas at standard temperature and pressure (STP),  $\text{m}^3/\text{s}$

3.4.14  $x$ —thickness of insulation system or linear dimension in the heat flow direction, m

3.4.15  $\eta_{heater}$ —heater power constant

3.4.16  $\rho_g$ —density of boiloff gas at standard conditions,  $\text{kg}/\text{m}^3$

3.4.17  $\rho$ —bulk density of insulation system as-installed,  $\text{kg}/\text{m}^3$

## 4. Summary of Test Methods

4.1 This guide describes both absolute and comparative test methods for measuring the thermal performance of insulating materials and systems under cryogenic and vacuum conditions. The methods may use cryogenics or cryocoolers to provide the refrigeration for the cold side temperatures. The basis of heat flow measurement can be boiloff calorimetry, electrical power, or temperature response. An absolute apparatus means that the test chamber is fully guarded from peripheral heat leaks while a comparative apparatus indicates a partially guarded test chamber. A cylindrical apparatus indicates hollow cylindrical test specimen while a flat plate apparatus indicates a round disk test specimen. The general arrangement of a cylindrical boiloff apparatus is given in Fig. 2. The general arrangement of a flat plate boiloff apparatus is given in Fig. 3. Either apparatus can be designed as absolute or comparative depending on testing

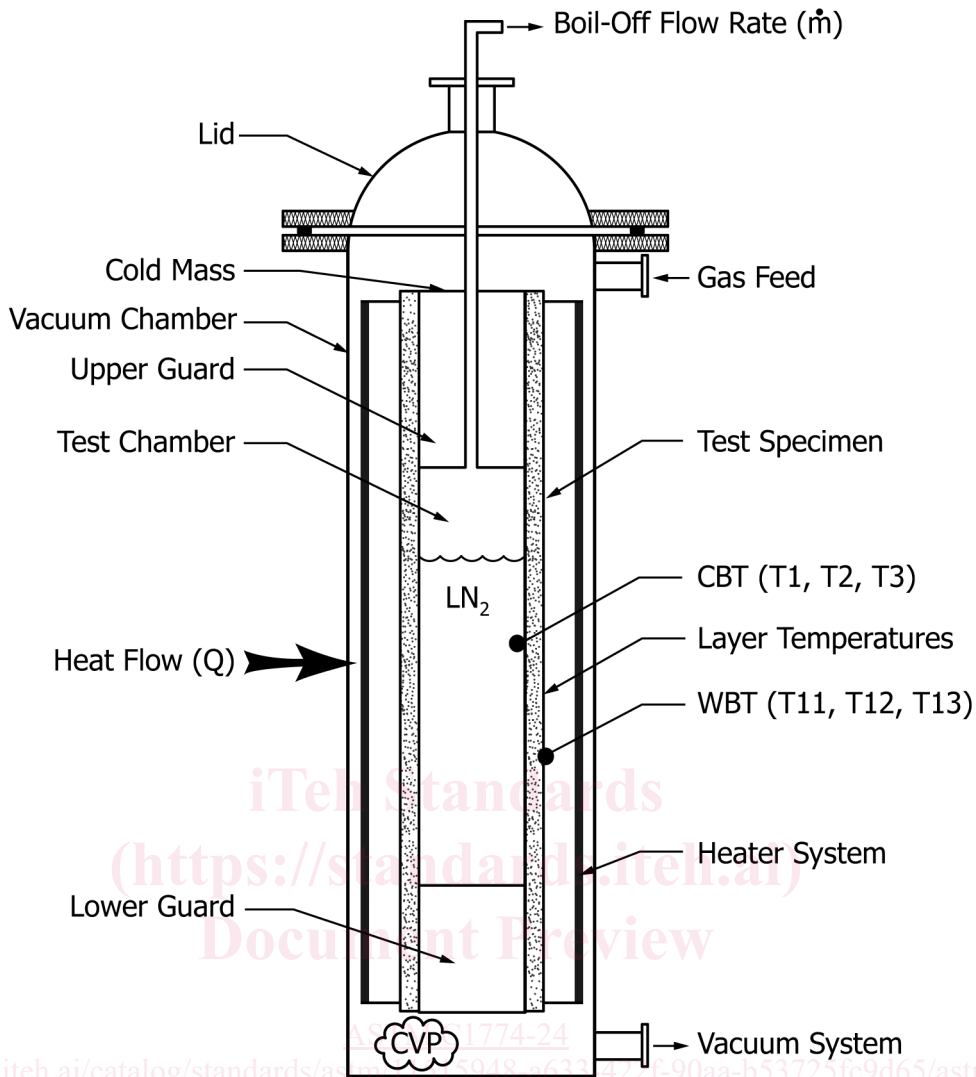

FIG. 2 General Arrangement of a Cylindrical Boiloff Apparatus (29)

needs. The relatively simplified comparative apparatus is useful for large numbers of specimens, similar specimens, quality control testing, or of course comparison testing. The general arrangement of an embedded heater apparatus that uses cryogenics for cooling is given in Fig. 4. The embedded heater apparatus is generally an absolute apparatus calibrated by temperature measurements under balanced heater inputs. The general arrangement of an electrical power apparatus that uses a cryocooler is given in Fig. 5.

## 5. Significance and Use

5.1 A key aspect in understanding the thermal performance of cryogenic insulation systems is to perform tests under representative and reproducible conditions, simulating the way that the materials are actually put together and used in service. Therefore, a large temperature differential across the insulation and a residual gas environment at some specific pressure are usually required. Added to these requirements are the complexities of thickness measurement at test condition after thermal contraction, verification of surface contact and/or mechanical loading after cooldown, and measurement of high

vacuum levels within the material. Accounting for the surface contact resistance can be a particular challenge, especially for rigid materials (32). The imposition of a large differential temperature in generally low density, high surface area materials means that the composition and states of the interstitial species can have drastic changes through the thickness of the system. Even for a single component system such as a sheet of predominately closed-cell foam, the composition of the system will often include air, moisture, and blowing agents at different concentrations and physical states and morphologies throughout the material. The system, as tested under a given set of WBT, CBT, and CVP conditions, includes all of these components (not only the foam material). The CVP can be imposed by design or can vary in response to the change in boundary temperatures as well as the surface effects of the insulation materials. In order for free molecular gas conduction to occur, the mean free path of the gas molecules must be larger than the spacing between the two heat transfer surfaces. The ratio of the mean free path to the distance between surfaces is the Knudsen number (see Guide C740 for further discussion). A Knudsen number greater than 1.0 is termed the molecular flow condition

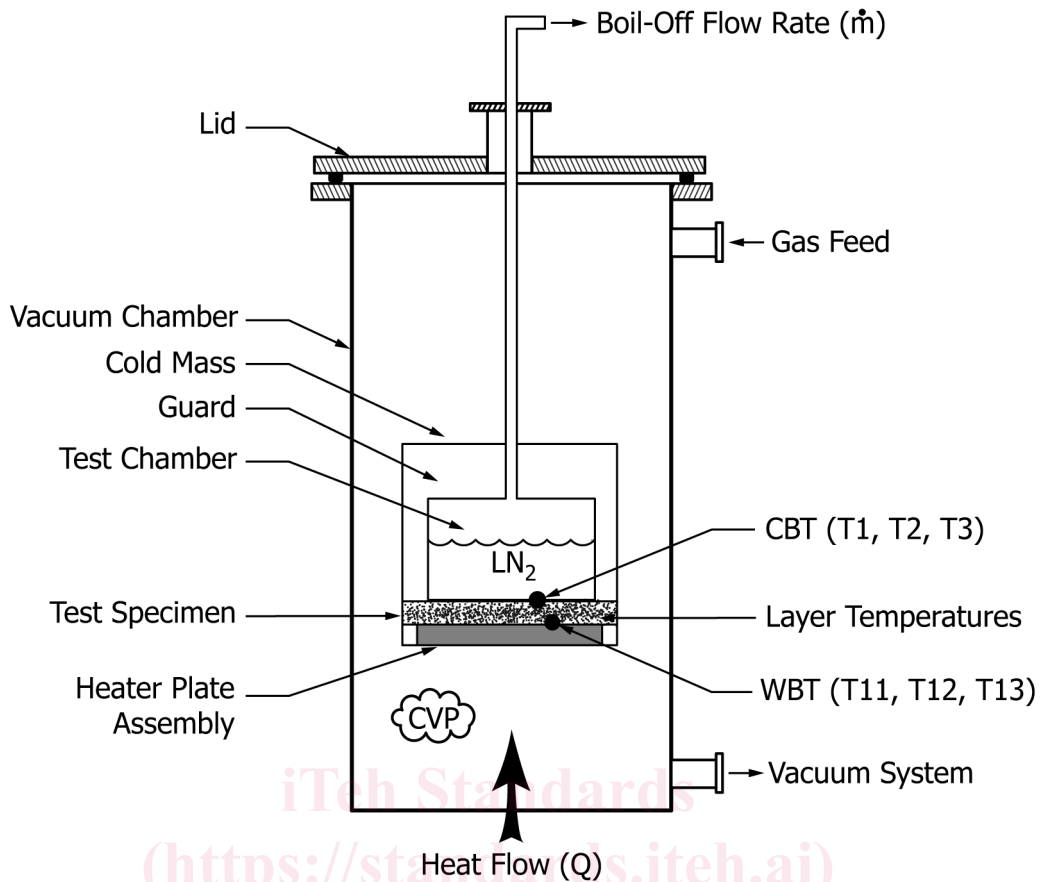

FIG. 3 General Arrangement of a Flat Plate Boiloff Apparatus (29)

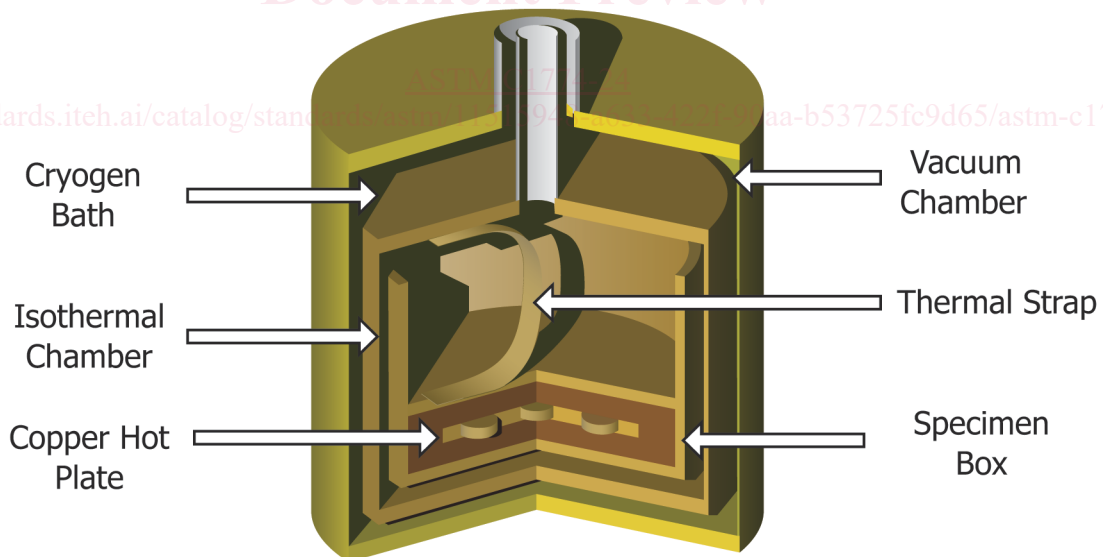

FIG. 4 General Arrangement of an Embedded Heater (Electrical Power) Apparatus That Uses a Cryogen (30)

while a Knudsen less than 0.01 is considered a continuum or viscous flow condition. Testing of cryogenic-vacuum insulation systems can cover a number of different intermediate or mixed mode heat transfer conditions.

5.2 Levels of thermal performance can be very high: heat flux values well below  $0.5 \text{ W/m}^2$  are measured. This level of

performance could, for example, correspond to a  $k_e$  below  $0.05 \text{ mW/m-K}$  ( $R$ -value = 2900 or higher) for the boundary temperatures of 300 K and 77 K and a thickness of 25 mm. At these very low rates of heat transmission, on the order of tens of milliwatts for an average size test apparatus, all details in approach, design, installation, and execution must be carefully

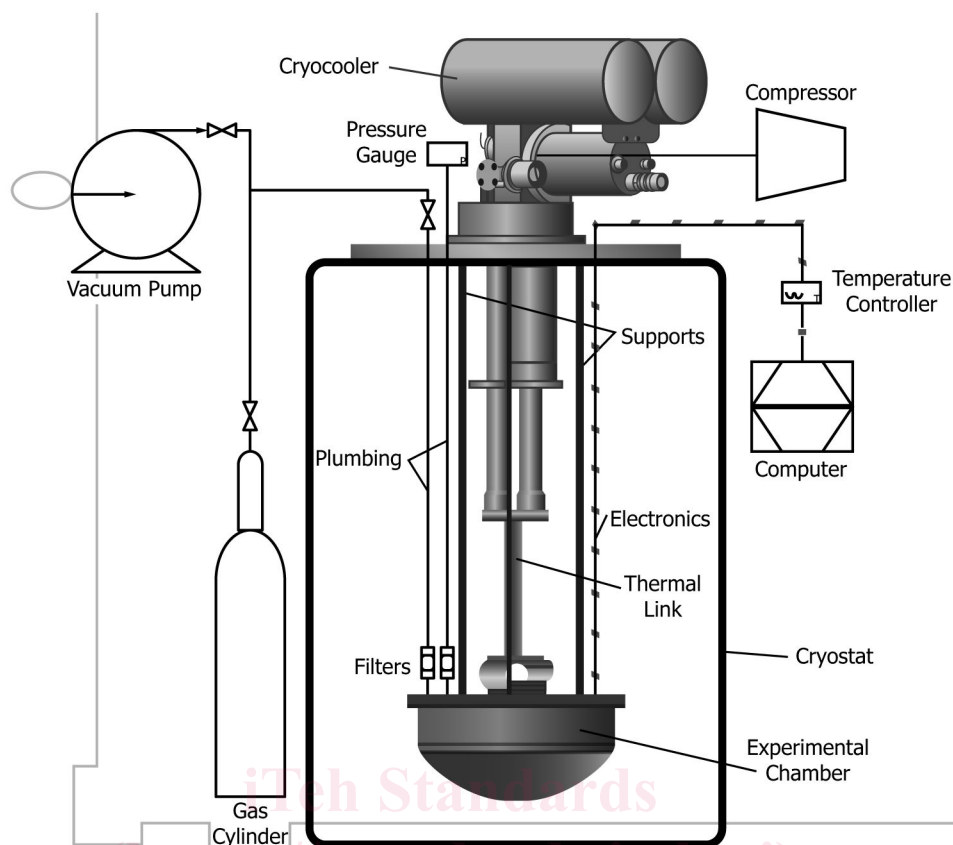

FIG. 5 General Arrangement of an Electrical Power Apparatus That Uses a Cryocooler (31)

considered to obtain a meaningful result. For example, lead wires for temperature sensors can be smaller diameter, longer length, and carefully installed for the lowest possible heat conduction to the cold mass. In the case of boiloff testing, the atmospheric pressure effects, the starting condition of the cryogen, and any vibration forces from surrounding facilities should also be considered. If an absolute test apparatus is to be devised, then the parasitic heat leaks shall be essentially eliminated by the integrated design of the apparatus and test methodology. The higher the level of performance (and usually the higher level of vacuum), the lower the total heat load and thus the parasitic portion shall be near zero. For a comparative apparatus, the parasitic heat leaks must be reduced to a level that is an acceptable fraction of the total heat load to be measured. And most importantly, for the comparative apparatus, the parasitic portion of the heat shall be consistent and repeatable for a given test condition.

**5.3 Boiloff Testing**—Boiloff testing can be performed with a number of cryogenics or refrigerants with normal boiling points below ambient temperature (29). The cold boundary temperature is usually fixed but can be easily adjusted higher by interposing a thermal resistance layer (such as polymer composite or any suitable material) between the cold mass and the specimen. However, the thermal contact resistance shall be fairly well understood and obtaining a *specific* cold-side temperature can be difficult. Liquid nitrogen ( $\text{LN}_2$ ) is a commonly used cryogen and can be handled and procured with relative ease and economy. Its 77 K boiling point at 1

atmosphere pressure is in a temperature range representative of many applications including liquid oxygen ( $\text{LO}_2$ ), liquid air (LAIR), and liquefied natural gas (LNG). The low level of ullage vapor heating with liquid nitrogen systems means that the vapor correction is minimal or even negligible. Liquid hydrogen ( $\text{LH}_2$ ), with a normal boiling point of 20 K, can be used with the proper additional safety precautions for working with a flammable fluid. Liquid helium (LHE), with a normal boiling point of 4 K, can also be used effectively, but with a significant rise in expense and complexity. The thermal performance, or heat flow rate (W), is a direct relation to the boiloff mass flow rate (g/s) by the heat of vaporization (J/g) of the liquid. Boiloff methods are therefore direct with respect to calculating a  $k_e$  or heat flux.

**5.4 Electrical Power Testing**—In some cases a boiloff method may not be the best option for thermal performance testing. Obtaining a cold boundary temperature below 77 K without additional safety constraints (liquid hydrogen) or unreasonable expense (liquid helium) is often the main reason. The use of electrical power methods provides a wide range of possible approaches without the constraints of a liquid-vapor interface and liquid management. Electrical power apparatus can be designed to use only cryocoolers, cryocoolers in conjunction with cryogenics or vapor shields, cryogenics to provide the refrigeration to maintain the desired cold boundary temperature, or any combination of these. The key experimental element is the electrical heater system(s), but the key challenge is the temperature sensor calibration at the low



temperatures. Temperature sensors are generally silicon diodes or platinum resistance thermometers. These methods are therefore indirect with respect to calculating effective thermal conductivity or heat flux.

5.5 *MLI*—Multilayer insulation systems are usually evacuated (designed for a vacuum environment). Materials used in MLI systems are highly anisotropic by nature. MLI systems exhibit heat flux values one or two orders of magnitude lower than the best available powder, fiber, or foam insulations under vacuum conditions. The thermal performance of multilayer insulations will vary from specimen to specimen due to differences in the material properties, such as the emittance of the reflective shields, and differences in construction, such as layer density and the way seams or joints are made. MLI systems can vary due to environmental conditioning and the presence of foreign matter such as oxygen or water vapor. MLI systems can vary due to aging, settling, or exposure to excessive mechanical pressures which could wrinkle or otherwise affect the surface texture of the layers. For these reasons, it is imperative that specimen materials be selected carefully to obtain representative specimens. It is recommended that several specimens of any one MLI system be tested with at least three tests performed on each specimen. Further information, including installation methods and typical thermal performance data are given in Guide C740.

5.6 *High Performance Insulation Systems*—High performance insulation systems, ranging from aerogels at ambient pressure to evacuated powders to MLI under high vacuum conditions, are typical for the more-demanding applications in cryogenic equipment and processes. The requirements of high performance mean low rates of heat energy transfer (in the range of milliwatts) and even more demanding requirements for accurately measuring these small heat leakage rates. Achieving such measurements requires a sound experimental approach and design, specialized vacuum equipment, a well thought-out methodology, and careful execution and handling of data.

NOTE 1—The current lack of Certified Reference Materials (CRMs), or even internal laboratory reference materials, that are characterized under cryogenic-vacuum conditions underscores the need for round robin testing, inter-laboratory studies, and development of robust analytical tools based on these experimental results.

## 6. Apparatuses

6.1 The test apparatuses can be designed for any or all of the following conditions, as limited by practicality and suitability in results: evacuated, soft vacuum, or ambient pressure (high vacuum or residual gas environments).

6.2 In all cases, the focus is generally on large temperature differences, but small temperature differences can also be accommodated by specific design modification or by interposing appropriate thermal resistances (insulation materials) between the warm and cold boundaries.

6.3 The design approach and specific dimensional details must be sufficiently identified and understood for accurate thermal conductivity and heat flux determinations to be made. The effective heat transfer areas are defined by the median line(s), or center of the gap(s), between the test measurement chamber (or the heat metered section) and the connecting thermal guard(s). Typically there is a gap between the metered section and the guard section(s). The metered section area shall be determined, either by measurements or detailed analysis and calculations, according to the center of this gap. Test Method C177, Section 6.4, provides further information on the physical design and thermal considerations for the gap.

6.4 *Boiloff Calorimeter Apparatuses*—In these apparatuses, the thermal energy transferred through an insulation specimen is measured by a boiloff calorimeter method. Ideally, a boiling fluid maintained at constant saturation conditions intercepts all of the energy crossing the cold boundary in a direction normal to the plane of the insulation layers in the central or inner portion of a specimen. This energy is absorbed by the vaporization of the calorimetric fluid (cryogen) that is subsequently vented. For absolute cylindrical boiloff methods and lower fill levels (wetted surface area less than 75% for liquid nitrogen and at all times for liquid hydrogen or liquid helium), the temperature of the gas exiting the test measurement tank should be measured and the change in sensible heat added to the energy from boiloff flow (see Note 2 and Note 5). Heat flux  $q$  and effective thermal conductivity  $k_e$  are calculated from thermodynamic properties of the fluid and the measured boiloff flow rate. Measurements of the mechanical compressive force applied to the specimen and the separation between hot and cold boundary surfaces in contact with the insulation can also be obtained for the flat plate version as required. Typical characteristics of boiloff calorimeter apparatuses are given in Table 1. Typical requirements for cylindrical and flat-plate calorimeters that are suitable for use with this method are described in Annex A1 through A1.3. Particular design features required for safety are discussed in Section 8.

6.5 *Electrical Power Apparatuses*—In these apparatuses, the electrical power is the primary measurement and temperature sensor calibrations are of critical importance.

6.5.1 *Embedded Heater Apparatus*—An isothermal test specimen box made out of a suitable high thermal conductivity

TABLE 1 Typical Characteristics of Boiloff Calorimeter Apparatuses

Geometry	Type	Heat Flux Range (W/m <sup>2</sup> )	$k_e$ Range (mW/m-K)	Typical Specimen Size
Cylindrical	Absolute	0.1 to 500	0.01 to 60	1-m length; up to 50-mm thickness
Cylindrical	Comparative	1 to 500	0.1 to 60	0.5-m length; up to 30-mm thickness
Flat Plate	Absolute	1 to 1,000	0.05 to 100	200-mm diameter; up to 30-mm thickness
Flat Plate	Comparative	10 to 1,000	0.5 to 100	75-mm or 200-mm diameter; up to 30-mm thickness

material, such as OFHC copper, equipped with a suitable temperature sensor and an electrical heater. The hot plate heater is used to apply heat for the thermal conductivity measurements; the test specimen box heater assists in raising the overall temperature. The box is thermally linked to and suspended inside an isothermal vacuum tight chamber that is also constructed from OFHC copper. This chamber is placed inside the vacuum can and equipped with a heater and a temperature sensor. This arrangement allows variation of the temperature of the chamber and its contents well above that of a cryogen bath surrounding the vacuum can. The center of each test specimen half is machined to make room for the isothermal copper hot plate which is placed in between the two halves, thus assuring that all of the heat passes through the specimen, except for that conducted along the heater wires which are thermally linked to a cryogen bath.

**6.5.2 Cryocooler Apparatus**—The cryocooler-based electrical power cryostat apparatus includes an experimental chamber that is thermally linked to an appropriate cryocooler refrigeration system. Designs can be flat plate or cylindrical. The method works by creating axial heat transfer through the insulation test specimen and measuring the corresponding temperatures within the test specimen.

**6.5.3 Guarded Heater Apparatus**—Test Methods C177 or C518 could be adapted with the cryogenic and vacuum guidelines of this Guide to provide a means of testing using a heater apparatus. Test Method C1667 provides an example and guidance on adapting an established test apparatus for the purpose of test complex insulation systems such as panels and other composites.

## 7. Test Specimens and Preparation

**7.1 Materials** include foams, powders, aerogels, and MLI in forms including disks, panels, blankets, clamshells, and loose fill. Ancillary materials such as tapes, fasteners, packaging, etc. must be carefully evaluated for outgassing and temperature compatibilities. Upper-use temperatures and overall vacuum behavior of all materials must be known in order to obtain the desired test conditions as well as for operational safety during evacuation and heating. As differences between test samples and full-sized insulation may result in differences between data and actual performance of an insulation system, all aspects of the test specimen design configuration, preparation, and installation must be carefully considered. For example, a flat disk test specimen may be reduced in thickness in order to achieve minimal edge effect (parasitic heat) but then be less than representative of the typical field installed thickness. An example with a blanket type MLI system is a seam joining method, representative of the actual field installed system and applied similarly to the test specimen, which overwhelms the total heat load to be measured.

**7.2 Bulk-Fill Materials**—Bulk-fill materials may be tested by using a containment sleeve that does not thermally connect with the cold mass assembly (33). The bulk density, as-tested, must be measured and reported. The thickness measurement can be taken by reference from the containment apparatus with any necessary compensation due to thermal contraction by design or calculation. Temperature sensors can be placed

through the thickness with proper care in placement of the tips and execution of the lead wires.

**7.3 Monoliths, Clam-Shells, and Panels**—Monolithic materials, as well as clam-shells and panel type insulation test specimens, should be tested with special attention to the surface thermal contact and overall fit-up of the specimen within the apparatus. Thickness measurements must be devised with an accounting for cryogenic-vacuum effects during testing. Temperature sensors must be arranged so that surface contacts with the specimen are not disturbed.

**7.4 Blankets and Layered Constructions**—Blankets and layered constructions can be tested in a multitude of arrangements of thicknesses and combinations. Layers should extend to cover the cold mass surface of the apparatus. Edges of the specimens must be carefully examined during installation to avoid or identify thermal short circuits. Temperature sensors can be imbedded within layers with proper attention to lead wire lengths. Thicknesses can be measured as the insulation test specimen is constructed to allow for intermediate thermal conductivity calculations.

**7.5 MLI**—Multilayer insulation specimens include reflector layers and spacer layers. The MLI may be applied as continuous roll-wrapped product, blankets, multiple sub-blankets, layer-by-layer overlap, layer-by-layer interleaved, helical strip wraps, or spiral wrapping techniques. Guide C740 provides further details on the materials and processes involved with MLI systems. All manner of different materials, combinations, and constructions cannot be addressed here, but general guidelines for preparation are given as follows. Documentation of all installation and preparation steps, along with consistent execution of these steps, is the key to reliable and comparable results among similar MLI systems (11).

**7.5.1 Flat Plate**—Cut spacers to the diameter of the hot and cold boundary plates. Cut the radiation shield to a diameter that is approximately 5 mm less than that of the spacer. The maximum specimen thickness to be tested using this test method shall be 0.05 times the plate width.

**7.5.2 Cylindrical**—The installation approach defines the dimensions of the spacers relative to the reflectors. In all cases, the length of the spacer should be approximately the same dimension as the cold mass length. Aluminized tape and aluminum foil tape (low out-gassing types) can be used to affix the layers or blankets as required. Layer by layer constructions can be interleaved (overlapped) in pairs. The amount of overlap should be from 10 to 30 mm and accordingly specified. If layers are combined into sub-blankets and joined, a parasitic delta heat leak can occur and must be recognized. The joining can be overlapped, folded over, introduce a gap (or crack), or other non-uniformities. The techniques must be carefully defined and executed; analysis of these localized effects on the total heat flux must be done for accurate conclusions about the test data.

**7.5.3** Visually inspect the materials and cut the test specimens from material that is free of tears, abnormal creases, or other defects. Clean gloves should be worn when handling materials and specimens and handling, in general, should be kept to a minimum. Use a template to ensure that each layer of