



Designation: C210 – 95 (Reapproved 2024)

Standard Test Method for Reheat Change of Insulating Firebrick¹

This standard is issued under the fixed designation C210; the number immediately following the designation indicates the year of original adoption or, in the case of revision, the year of last revision. A number in parentheses indicates the year of last reapproval. A superscript epsilon (ϵ) indicates an editorial change since the last revision or reapproval.

This standard has been approved for use by agencies of the U.S. Department of Defense.

1. Scope

1.1 This test method covers the determination of the permanent linear (and volume) change of insulating firebrick upon reheating under prescribed conditions.

1.2 The values stated in inch-pound units are to be regarded as the standard. The values given in parentheses are for information only.

1.3 *This standard does not purport to address all of the safety concerns, if any, associated with its use. It is the responsibility of the user of this standard to establish appropriate safety, health, and environmental practices and determine the applicability of regulatory limitations prior to use.*

1.4 *This international standard was developed in accordance with internationally recognized principles on standardization established in the Decision on Principles for the Development of International Standards, Guides and Recommendations issued by the World Trade Organization Technical Barriers to Trade (TBT) Committee.*

2. Referenced Documents

2.1 *ASTM Standards:*²

- [C24 Test Method for Pyrometric Cone Equivalent \(PCE\) of Fireclay and High-Alumina Refractory Materials](#)
- [C155 Classification of Insulating Firebrick](#)
- [E230/E230M Specification for Temperature-Electromotive Force \(emf\) Tables for Standardized Thermocouples](#)
- [E1256 Test Methods for Radiation Thermometers \(Single Waveband Type\)](#)

3. Significance and Use

3.1 Insulating firebrick (IFB) are classified by their bulk density and reheat change (see Classification [C155](#)). This test

¹ This test method is under the jurisdiction of ASTM Committee [C08](#) on Refractories and is the direct responsibility of Subcommittee [C08.03](#) on Physical Properties.

Current edition approved April 1, 2024. Published April 2024. Originally approved in 1946. Last previous edition approved in 2019 as C210 – 95 (2019). DOI: 10.1520/C0210-95R24.

² For referenced ASTM standards, visit the ASTM website, www.astm.org, or contact ASTM Customer Service at service@astm.org. For *Annual Book of ASTM Standards* volume information, refer to the standard's Document Summary page on the ASTM website.

method defines thermal stability by measurement of IFB's reheat change following 24 h at a test temperature.

3.2 Since this test exposes the entire sample to an isothermal temperature condition, the user should be aware that most applications for IFB involve a thermal gradient which may cause the IFB's dimensions to change differentially.

4. Apparatus

4.1 The test kiln shall be capable of maintaining the required temperature with a variation of not more than one half a standard pyrometric cone over the hearth area during the prescribed heating schedule. If a gas- or oil-fired kiln is used, it shall be of the downdraft type and of such a design as not to permit the flame from the burner to impinge upon the test specimens. The kiln atmosphere during the test shall be kept as oxidizing as is practicable.

5. Procedure

5.1 Test Specimens and Measurements:

5.1.1 The test specimens shall consist of three brick ([Note 1](#)) measuring 9 in. by 4½ in. by 2½ in. or 3 in. (228 mm by 114 mm by 64 mm or 76 mm) or three pieces of these dimensions cut out of larger shapes.

[NOTE 1](#)—Three supporting brick from the same lot as the test specimens are required also, so that the test sample is comprised of six brick.

5.1.2 Each specimen shall be labeled with ceramic paint, and before and after heating they shall be carefully measured for length ([Note 2](#)), width, and thickness. Three measurements ([Note 3](#)) to the nearest 0.02 in. (0.5 mm) shall be taken for each dimension and the average of these shall be used. Each dimension shall be measured in three places along the longitudinal center line on opposite faces, one measurement at the center of the line and one ½ in. (13 mm) in from each edge. [Fig. 1](#) shows the location at which these measurements are to be made.

[NOTE 2](#)—For classifying IFB according to Classification [C155](#), obtain the reheat change from the 9 in. (228 mm) dimension measurements only.

[NOTE 3](#)—Because of the large pore size of some IFB, it is difficult to measure by means of calipers directly on the brick surfaces. Accuracy may be obtained by holding two small pieces of flat polished steel plate of known thickness against the faces between which the dimension is to be obtained, and caliper on the outside steel surfaces rather than directly

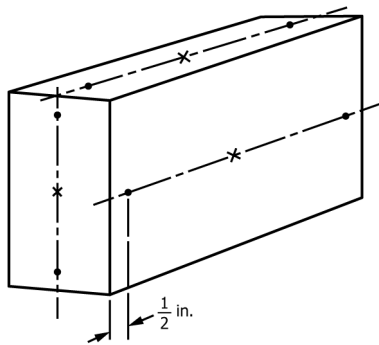

NOTE 1—The dots on the center line of each face are 1/2 in. (13 mm) in from each edge, and the cross on the axis is in the center. These positions indicate the points at which three measurements for each dimensions are to be made.

FIG. 1 Test Brick Showing Measurement Locations

against the brick surfaces. It is permissible to use a measuring device to obtain the dimensions of the brick, provided the measurements are not affected by large pores in the surface.

5.2 Placing Test Specimens in Kiln:

5.2.1 Place the test specimens in the kiln so that each will rest on a 9 in. by 2 1/2 in. or 3 in. (228 mm by 64 mm or 76 mm) face. Place each specimen upon the 9 in. by 2 1/2 in. or 3 in. face of a supporting brick that shall be from the same lot as the test specimen. Place between the test specimen and the supporting member a layer of suitable refractory material, that is nonreactive under the test conditions and passes an ASTM No. 16 (1.18 mm) sieve (equivalent to a 14-mesh Tyler Standard Series) and retained on an ASTM No. 40 (425 μm) sieve (equivalent to a 35-mesh Tyler Standard Series). Place each specimen no closer than 1 1/2 in. (38 mm) from either the other test specimens or the furnace wall and parts.

6. Temperature Measurement

6.1 Measure the temperature within the kiln by means of an appropriate calibrated thermocouple. Refer to Table 1 and Table 2 of Specification E230/E230M for the tolerances and upper temperature limits for use of various thermocouples. At higher temperatures, the thermocouple may be withdrawn and a calibrated optical or radiation pyrometer (refer to Test Methods E1256) can be used. Place the hot junction of the thermocouple or sight the pyrometer so as to register the temperature of the test specimens. Make temperature readings at intervals not greater than 15 min. Check the kiln periodically by thermocouples, pyrometers, or pyrometric cones (refer to Test Method C24) to ensure that temperature over the hearth does not differ by more than 25 °F (14 °C) or one half-cone.

7. Test Temperature Schedules and Duration of Test

7.1 The temperature to be used for the test shall depend on the classification into which the IFB falls (see Classification C155).

7.2 The heating schedules for the various classes of IFB are given in Table 1. Maintain the maximum temperature for a period of 24 h, and leave the specimens in the kiln until the temperature has fallen to about 800 °F (430 °C). Blisters may

develop on the surface of the test brick, in which case remove them by rubbing their surfaces very lightly with a fine abrasive block before remeasuring in accordance with 5.1.2.

8. Calculation and Report

8.1 Reheat Change—Calculate the reheat change in percent from the average measurement for the dimension obtained before and after reheating.

8.2 Reheat Volume Change—When the reheat volume change is requested, calculate it from the average measurement for the three dimensions obtained before and after reheating, as follows:

$$V = [(V_o - V_f)/V_o] \times 100 \tag{1}$$

where:

- V = volume change, percent,
- V_o = original volume, and
- V_f = final volume.

8.3 Report—When the test is conducted for evaluating IFB in accordance with Classification C155, the average linear change for the 9 in. (228 mm) dimension *only* shall be reported; otherwise, or when specified, the average of the reheat change for the length, width, and thickness shall be reported and, if requested, the average reheat volume change.

9. Precision and Bias

9.1 Interlaboratory Test Program—An interlaboratory test program between six laboratories was conducted. Each laboratory received three samples each of three IFBs: K-20, K-26 LI, and K-3000. The bricks were provided by Thermal Ceramics. The laboratories participating were C.E. Minerals, Orton RRC, North American Refractories, National Refractories, Thermal Ceramics, and Premier Refractories.

9.2 Precision:

9.2.1 Repeatability—The maximum permissible difference due to test error between two test results obtained by one operator on the same material is given by the repeatability interval and the relative repeatability interval (coefficient of variation). The 95 % repeatability intervals are given in Table 2. Two test results that do not differ by more than the repeatability interval will be considered the same and, conversely, two test results that do differ by more than the repeatability interval will be considered different.

9.2.2 Reproducibility—The maximum permissible difference due to test error between two test results obtained by two operators in different laboratories on the same type of material using the same type of test equipment is given by the reproducibility interval and relative reproducibility interval (coefficient of variation). The 95 % reproducibility intervals are given in Table 2. Two test results that do not differ by more than the reproducibility interval will be considered the same and, conversely, two test results that do differ by more than the reproducibility interval will be considered different.

9.3 Bias—No justifiable bias statement is possible since the true values of the properties of the reference material are not defined.