



## Designation: D88/D88M – 07 (Reapproved 2024)

American Association State  
Highway and Transportation Officials Standard  
AASHTO No: T72  
Method 304—Federal Test  
Method Standard No. 791b  
Replaces Method 4285 of Federal Test  
Method Standard No. 141A

# Standard Test Method for Saybolt Viscosity<sup>1</sup>

This standard is issued under the fixed designation D88/D88M; the number immediately following the designation indicates the year of original adoption or, in the case of revision, the year of last revision. A number in parentheses indicates the year of last reapproval. A superscript epsilon ( $\epsilon$ ) indicates an editorial change since the last revision or reapproval.

*This standard has been approved for use by agencies of the U.S. Department of Defense.*

## 1. Scope

1.1 This test method covers the empirical procedures for determining the Saybolt Universal or Saybolt Furol viscosities of petroleum products at specified temperatures between 21 and 99 °C [70 and 210 °F]. A special procedure for waxy products is indicated.

NOTE 1—Test Methods D445 and D2170/D2170M are preferred for the determination of kinematic viscosity. They require smaller samples and less time, and provide greater accuracy. Kinematic viscosities may be converted to Saybolt viscosities by use of the tables in Practice D2161. It is recommended that viscosity indexes be calculated from kinematic rather than Saybolt viscosities.

1.2 The values stated in either SI units or inch-pound units are to be regarded separately as standard. The values stated in each system are not necessarily exact equivalents; therefore, to ensure conformance with the standard, each system shall be used independently of the other, and values from the two systems shall not be combined.

1.3 *This standard does not purport to address all of the safety concerns, if any, associated with its use. It is the responsibility of the user of this standard to establish appropriate safety, health, and environmental practices and determine the applicability of regulatory limitations prior to use.*

1.4 *This international standard was developed in accordance with internationally recognized principles on standardization established in the Decision on Principles for the Development of International Standards, Guides and Recommendations issued by the World Trade Organization Technical Barriers to Trade (TBT) Committee.*

<sup>1</sup> This test method is under the jurisdiction of ASTM Committee D08 on Roofing and Waterproofing and is the direct responsibility of Subcommittee D08.05 on Solvent-Bearing Bituminous Compounds for Roofing and Waterproofing.

Current edition approved May 1, 2024. Published May 2024. Originally approved in 1921. In 1923, combined with former Methods D47. Last previous edition approved in 2019 as D88/D88M – 07 (2019)<sup>ε1</sup>. DOI: 10.1520/D0088\_D0088M-07R24.

## 2. Referenced Documents

### 2.1 ASTM Standards:<sup>2</sup>

- D93 Test Methods for Flash Point by Pensky-Martens Closed Cup Tester
- D117 Guide for Sampling, Test Methods, and Specifications for Electrical Insulating Liquids
- D140/D140M Practice for Sampling Asphalt Materials
- D244 Test Methods and Practices for Emulsified Asphalts
- D445 Test Method for Kinematic Viscosity of Transparent and Opaque Liquids (and Calculation of Dynamic Viscosity)
- D2161 Practice for Conversion of Kinematic Viscosity to Saybolt Universal Viscosity or to Saybolt Furol Viscosity
- D2170/D2170M Test Method for Kinematic Viscosity of Asphalts
- D4057 Practice for Manual Sampling of Petroleum and Petroleum Products
- D4177 Practice for Automatic Sampling of Petroleum and Petroleum Products
- E1 Specification for ASTM Liquid-in-Glass Thermometers
- E11 Specification for Woven Wire Test Sieve Cloth and Test Sieves
- E102/E102M Test Method for Saybolt Furol Viscosity of Bituminous Materials at High Temperatures

## 3. Terminology

### 3.1 Definitions:

3.1.1 *Furol*—an acronym of “Fuel and Road Oils.”

3.1.2 *Saybolt Furol viscosity*—the corrected efflux time in seconds of 60 mL of sample flowing through a calibrated Furol orifice under specified conditions. The viscosity value is reported in Saybolt Furol seconds, abbreviated SFS, at a specified temperature.

<sup>2</sup> For referenced ASTM standards, visit the ASTM website, www.astm.org, or contact ASTM Customer Service at service@astm.org. For *Annual Book of ASTM Standards* volume information, refer to the standard’s Document Summary page on the ASTM website.

3.1.3 *Saybolt Universal viscosity*—the corrected efflux time in seconds of 60 mL of sample flowing through a calibrated Universal orifice under specified conditions. The viscosity value is reported in Saybolt Universal seconds, abbreviated SUS, at a specified temperature.

4. Summary of Test Method

4.1 The efflux time in seconds of 60 mL of sample, flowing through a calibrated orifice, is measured under carefully controlled conditions. This time is corrected by an orifice factor and reported as the viscosity of the sample at that temperature.

5. Significance and Use

5.1 This test method is useful in characterizing certain petroleum products, as one element in establishing uniformity of shipments and sources of supply.

5.2 See Guide D117 for applicability to mineral oils used as electrical insulating oils.

5.3 The Saybolt Furol viscosity is approximately one tenth the Saybolt Universal viscosity, and is recommended for

characterization of petroleum products such as fuel oils and other residual materials having Saybolt Universal viscosities greater than 1000 s.

5.4 Determination of the Saybolt Furol viscosity of bituminous materials at higher temperatures is covered by Test Method E102/E102M.

6. Apparatus

6.1 *Saybolt Viscometer and Bath*, as shown in Fig. 1 and described in Annex A1.

6.2 *Withdrawal Tube*, as shown in Fig. 2.

6.3 *Thermometer Support*, as shown in Fig. 3.

6.4 *Saybolt Viscosity Thermometers*, as listed in Table 1, for reading the temperature of the sample. Each thermometer shall conform to the requirements listed in Specification E1 for that ASTM Thermometer Number.

6.5 *Bath Thermometers*—Saybolt Viscosity thermometers, or any other temperature-indicating means of equivalent accuracy.

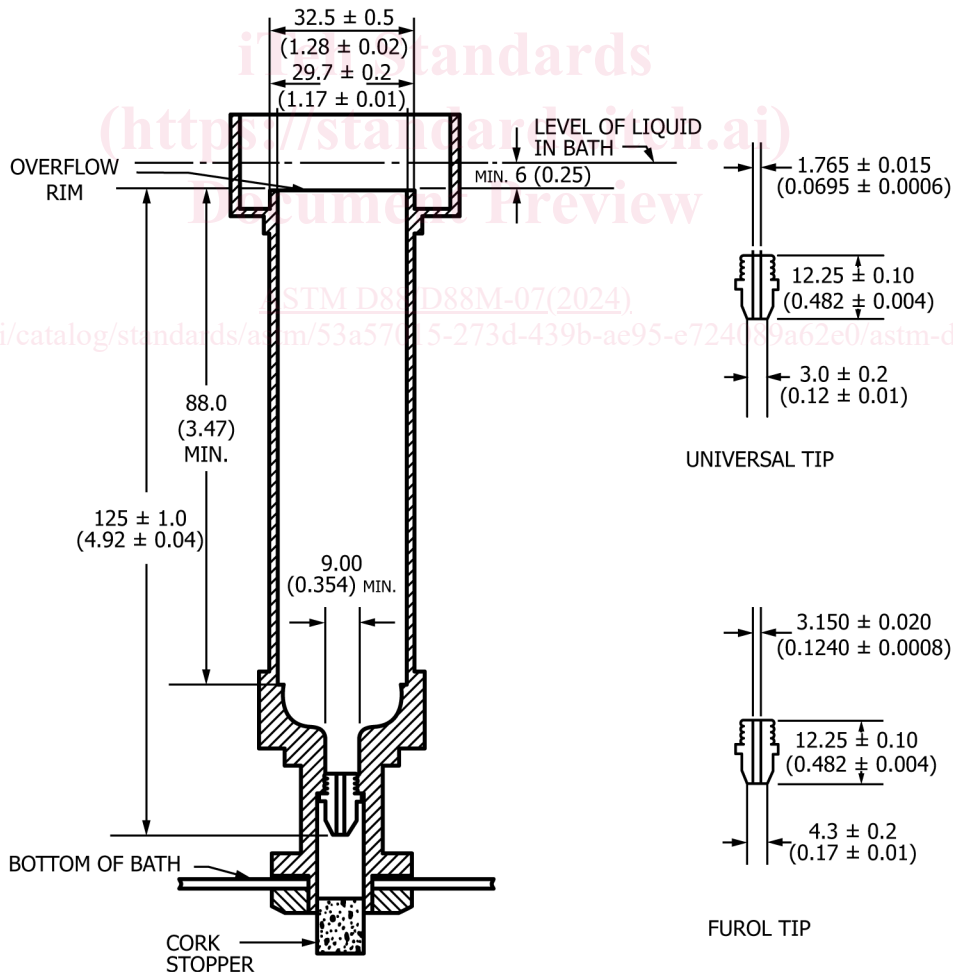

NOTE 1—All dimensions are in millimetres (inches).

FIG. 1 Saybolt Viscometer with Universal and Furol Orifice

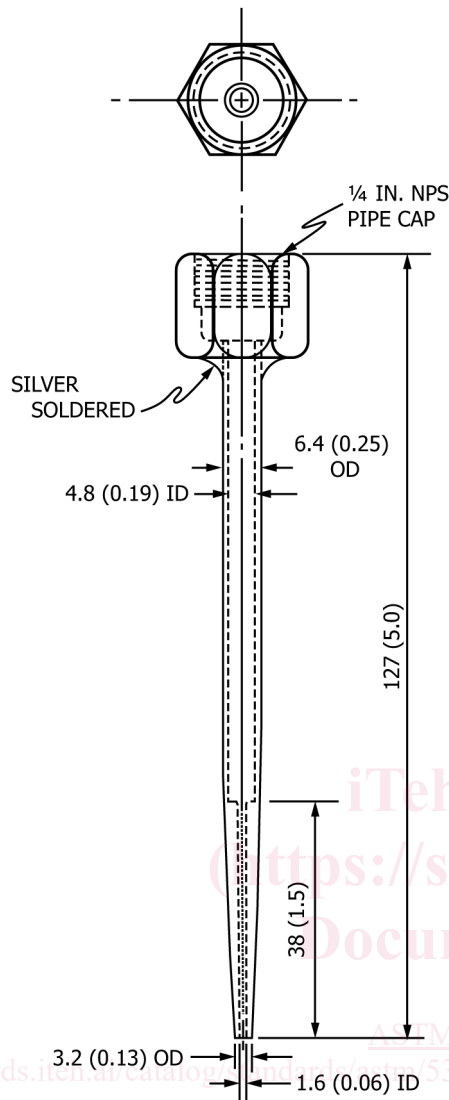

NOTE 1—All dimensions are in millimetres (inches).

FIG. 2 Withdrawal Tube for Use with Saybolt Viscometer

6.6 *Filter Funnel*, as shown in Fig. 4, equipped with interchangeable 150  $\mu\text{m}$  (No. 100) and 75  $\mu\text{m}$  (No. 200) wire-cloth inserts meeting the requirements of Specification E11 with respect to the wire cloth.

6.7 *Receiving Flask*, as shown in Fig. 5.

6.8 *Timer*, graduated in tenths of a second, and accurate to within 0.1 % when tested over a 60 min interval. Electric timers are acceptable if operated on a controlled frequency circuit.

## 7. Sampling

7.1 Sample the material in accordance with Practice D140/ D140M, D4057, or D4177, as appropriate.

## 8. Preparation of Apparatus

8.1 Use a Universal orifice or tip for lubricants and distillates with efflux times greater than 32 s to give the desired

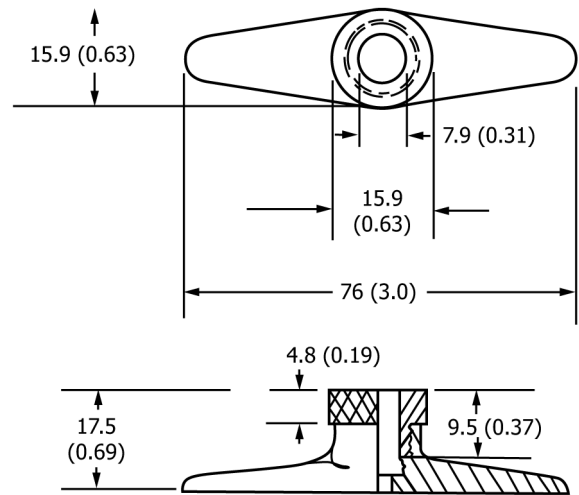

NOTE 1—All dimensions are in millimetres (inches).

FIG. 3 Thermometer Support

TABLE 1 ASTM Saybolt Viscosity Thermometers

Standard Test Temperature °C [°F]	ASTM Thermometer No.	Thermometer	
		Range °C [°F]	Subdivisions, °C [°F]
21.1 [70]	17C [17F]	19 to 27	0.1 [0.2]
		[66 to 80]	
25.0 [77]	17C [17F]	19 to 27	0.1 [0.2]
		[66 to 80]	
37.8 [100]	18C [18F]	34 to 42	0.1 [0.2]
		[94 to 108]	
50.0 [122]	19C [19F]	49 to 57	0.1 [0.2]
		[120 to 134]	
54.4 [130]	19C [19F]	49 to 57	0.1 [0.2]
		[120 to 134]	
60.0 [140]	20C [20F]	57 to 65	0.1 [0.2]
		[134 to 148]	
82.2 [180]	21C [21F]	79 to 87	0.1 [0.2]
		[174 to 188]	
98.9 [210]	22C [22F]	95 to 103	0.1 [0.2]
		[204 to 218]	

accuracy. Liquids with efflux times greater than 1000 s are not conveniently tested with this orifice.

8.2 Use a Furol orifice or tip for residual materials with efflux times greater than 25 s to give the desired accuracy. See also 5.3.

8.3 Clean the viscometer thoroughly with an appropriate solvent of low toxicity, then remove all solvent from the viscometer and its gallery. Clean the receiving flask in the same manner.

NOTE 2—The plunger commonly supplied with the viscometer should never be used for cleaning; its use might damage the overflow rim and walls of the viscometer.

8.4 Set up the viscometer and bath in an area where they will not be exposed to drafts or rapid changes in air temperature, and dust or vapors that might contaminate a sample.

8.5 Place the receiving flask (Fig. 5) beneath the viscometer so that the graduation mark on the flask is from 100 to 130 mm