



Designation: D2170/D2170M – 24



Designation: 319/84 (89)

Standard Test Method for Kinematic Viscosity of Asphalts¹

This standard is issued under the fixed designation D2170/D2170M; the number immediately following the designation indicates the year of original adoption or, in the case of revision, the year of last revision. A number in parentheses indicates the year of last reapproval. A superscript epsilon (ϵ) indicates an editorial change since the last revision or reapproval.

1. Scope

1.1 This test method covers procedures for the determination of kinematic viscosity of liquid asphalts, road oils, and distillation residues of liquid asphalts all at 60 °C [140 °F] and of liquid asphalt binders at 135 °C [275 °F] (see table notes, 11.1) in the range from 6 to 100 000 mm²/s [cSt].

1.2 Results of this test method can be used to calculate viscosity when the density of the test material at the test temperature is known or can be determined. See Annex A1 for the method of calculation.

NOTE 1—This test method is suitable for use at other temperatures and at lower kinematic viscosities, but the precision is based on determinations on liquid asphalts and road oils at 60 °C [140 °F] and on asphalt binders at 135 °C [275 °F] only in the viscosity range from 30 to 6000 mm²/s [cSt].

NOTE 2—Modified asphalt binders or asphalt binders that have been conditioned or recovered are typically non-Newtonian under the conditions of this test. The viscosity determined from this method is under the assumption that asphalt binders behave as Newtonian fluids under the conditions of this test. When the flow is non-Newtonian in a capillary tube, the shear rate determined by this method may be invalid. The presence of non-Newtonian behavior for the test conditions can be verified by measuring the viscosity with viscometers having different-sized capillary tubes. The defined precision limits in 11.1 may not be applicable to non-Newtonian asphalt binders.

1.3 **Warning**—Mercury has been designated by the United States Environmental Protection Agency (EPA) and many state agencies as a hazardous material that can cause central nervous system, kidney, and liver damage. Mercury, or its vapor, may be hazardous to health and corrosive to materials. Caution should be taken when handling mercury and mercury-containing products. See the applicable product Material Safety Data Sheet (MSDS) or Safety Data Sheet (SDS) for details and the EPA's website—<http://www.epa.gov/mercury/faq.htm>—for additional information. Users should be aware

¹ This test method is under the jurisdiction of ASTM Committee D04 on Road and Paving Materials and is the direct responsibility of Subcommittee D04.44 on Rheological Tests. In the IP this test method is under the jurisdiction of the Standardization Committee.

Current edition approved May 1, 2024. Published May 2024. Originally approved in 1963. Last previous edition approved in 2022 as D2170/D2170M – 22. DOI: 10.1520/D2170_D2170M-24.

that selling mercury, mercury-containing products, or both, in your state may be prohibited by state law.

1.4 The values stated in either SI units or inch-pound units are to be regarded separately as standard. The values stated in each system may not be exact equivalents; therefore, each system shall be used independently of the other. Combining values from the two systems may result in nonconformance with the standard.

1.5 The text of this standard references notes and footnotes that provide explanatory material. These notes and footnotes (excluding those in tables and figures) shall not be considered as requirements of the standard.

1.6 *This standard does not purport to address all of the safety concerns, if any, associated with its use. It is the responsibility of the user of this standard to establish appropriate safety, health, and environmental practices and determine the applicability of regulatory limitations prior to use.*

1.7 *This international standard was developed in accordance with internationally recognized principles on standardization established in the Decision on Principles for the Development of International Standards, Guides and Recommendations issued by the World Trade Organization Technical Barriers to Trade (TBT) Committee.*

2. Referenced Documents

2.1 ASTM Standards:²

- C670 Practice for Preparing Precision and Bias Statements for Test Methods for Construction Materials
- D8 Terminology Relating to Materials for Roads and Pavements
- D92 Test Method for Flash and Fire Points by Cleveland Open Cup Tester
- D341 Practice for Viscosity-Temperature Equations and Charts for Liquid Petroleum or Hydrocarbon Products
- D445 Test Method for Kinematic Viscosity of Transparent and Opaque Liquids (and Calculation of Dynamic Viscosity)

² For referenced ASTM standards, visit the ASTM website, www.astm.org, or contact ASTM Customer Service at service@astm.org. For *Annual Book of ASTM Standards* volume information, refer to the standard's Document Summary page on the ASTM website.

- [D446 Specifications and Operating Instructions for Glass Capillary Kinematic Viscometers](#)
- [D2162 Practice for Basic Calibration of Master Viscometers and Viscosity Oil Standards](#)
- [D2493/D2493M Practice for Viscosity-Temperature Chart for Asphalt Binders](#)
- [D3666 Specification for Minimum Requirements for Agencies Testing and Inspecting Road and Paving Materials](#)
- [D8055 Guide for Selecting an Appropriate Electronic Thermometer for Replacing Mercury Thermometers in D04 Road and Paving Standards](#)
- [E1 Specification for ASTM Liquid-in-Glass Thermometers](#)
- [E77 Test Method for Inspection and Verification of Thermometers](#)
- [E691 Practice for Conducting an Interlaboratory Study to Determine the Precision of a Test Method](#)
- [E879 Specification for Thermistor Sensors for General Purpose and Laboratory Temperature Measurements](#)
- [E1137/E1137M Specification for Industrial Platinum Resistance Thermometers](#)

3. Terminology

3.1 Definitions of Terms Specific to This Standard:

3.1.1 *automated viscometer, n*—apparatus which, in part or in whole, has mechanized one or more of the procedural steps indicated in Section 8 without changing the principle or technique of the basic manual apparatus.

3.1.1.1 *Discussion*—The essential elements of the apparatus in respect to dimensions, design, or operational characteristics are the same as those of the manual method. Apparatus which determine kinematic viscosity by physical techniques that are different than those used in this test method are not considered to be automated viscometers.

3.1.1.2 *Discussion*—Automated viscometers do not need to be reverse-flow type provided that the sensors (thermal, NIR, capacitive, other) used for sensing the meniscus of the sample can accurately detect an opaque sample.

3.1.2 *density, n*—the mass per unit volume of liquid. The SI unit of density is 1 kg/m³. The cgs unit of density is 1 g/cm³.

3.1.3 *kinematic viscosity, n*—the ratio of the viscosity to the density of a liquid, measured as the resistance to flow of a liquid under gravity.

3.1.3.1 *Discussion*—The SI unit of kinematic viscosity is m²/s; for practical use, a submultiple (mm²/s) is more convenient. The cgs unit of kinematic viscosity is 1 cm²/s and is called a stoke (symbol St). The centistoke (1 cSt = 10⁻² St) is 1 mm²/s and is often used.

3.1.4 *Newtonian viscosity, n*—the viscosity of a liquid that is shear-rate independent in which the rate of shear is linearly proportional to the shearing stress.

3.1.5 *non-Newtonian viscosity, n*—the viscosity of a liquid that is shear-rate dependent in which the rate of shear is not linearly proportional to the shearing stress.

3.1.6 *viscosity (coefficient of), n*—the ratio between the applied shear stress and rate of shear is called the coefficient of viscosity.

3.1.6.1 *Discussion*—This coefficient is a measure of the

resistance to flow of a liquid. It is commonly called the viscosity of the liquid. The cgs unit of viscosity is 1 g/cm·s (1 dyne·s/cm²) and is called a poise (P). The SI unit of viscosity is 1 Pa·s (1 N·s/m²) and is called a Pascal-second. One Pa·s is equivalent to 10 P.

3.2 For definitions of other terms used in this standard, refer to Terminology D8.

4. Summary of Test Method

4.1 The time is measured for a fixed volume of the liquid to flow through the capillary of a calibrated glass capillary viscometer under an accurately reproducible head and at a closely controlled temperature. The kinematic viscosity is then calculated by multiplying the efflux time in seconds by the viscometer calibration factor.

5. Significance and Use

5.1 The kinematic viscosity characterizes flow behavior. The method is used to determine the consistency of liquid asphalt as one element in establishing the uniformity of shipments or sources of supply. The specifications are usually at temperatures of 60 and 135 °C.

NOTE 3—The quality of the results produced by this standard are dependent on the competence of the personnel performing the procedure and the capability, calibration, and maintenance of the equipment used. Agencies that meet the criteria of Specification D3666 are generally considered capable of competent and objective testing, sampling, inspection, etc. Users of this standard are cautioned that compliance with Specification D3666 alone does not completely ensure reliable results. Reliable results depend on many factors; following the suggestions of Specification D3666 or some similar acceptable guideline provides a means of evaluating and controlling some of those factors.

6. Apparatus

6.1 *Viscometers*, capillary-type, made of borosilicate glass, annealed, suitable for this test are described in Annex A2 and include the following:

- 6.1.1 Cannon-Fenske viscometer for opaque liquids.
- 6.1.2 Zeitfuchs Cross-Arm viscometer.
- 6.1.3 Lantz-Zeitfuchs viscometer.
- 6.1.4 BS U-Tube modified reverse-flow viscometer.

6.1.5 Calibrated viscometers are available from commercial suppliers. Details regarding calibration of viscometers are given in Annex A3.

6.1.6 *Automated Viscometers*—Automated apparatus may be used if they duplicate the physical conditions, operations, or processes of the manual apparatus. Any viscometer, temperature measuring device, temperature control, and temperature-controlled bath or timing device incorporated in the automated apparatus shall conform to the specification for these components as stated in Section 6 of this test method. Flow times of less than 200 s are permitted; however, a kinetic energy correction shall be calculated and applied in accordance with Section 7 on Kinematic Viscosity Calculation of Specification D446. The kinetic energy correction shall not exceed 3.0 % of the measured viscosity. The automated apparatus shall be capable of determining kinematic viscosity of a viscosity oil standard (see A3.2.1) within the limits stated in Table 1. The precision shall be of statistical equivalence to or better (has less variability) than the manual apparatus.

6.2 *Thermometers*—Calibrated thermometers with suitable range and estimated measurement uncertainty of 0.02 °C [0.04 °F] or less at 95 % confidence interval listed on the calibration certificate and is one of the following:

6.2.1 A liquid-in-glass thermometer that is calibrated annually. The calibration shall be verified at the ice point in accordance with [Appendix X1](#). ASTM Kinematic Viscosity Thermometers 47C and 47F conforming to Specification [E1](#), and IP 35C and 35F are suitable for use at 60 °C [140 °F], and ASTM Kinematic Viscosity Thermometers 110C and 110F are suitable for use at 135 °C [275 °F].

NOTE 4—The specified thermometers in [6.2.1](#) are standardized as “total immersion” thermometers, which are designed to indicate temperatures correctly when just that portion of the thermometer containing the liquid is exposed to the temperature being measured and the remainder of the stem and expansion chamber at the top of the thermometer exposed to the room temperature. The practice of completely submerging the thermometer is not recommended. When a “total immersion” thermometer is completely submerged, corrections for each individual thermometer based on calibration under conditions of complete submergence should be determined and applied. If the thermometer is completely submerged in the bath during use, the pressure of the gas in the expansion chamber will be higher or lower than during standardization and may cause high or low readings on the thermometer.

6.2.2 A platinum resistance thermometer (PRT) with a sensor which conforms to the requirements of Specification [E1137/E1137M](#). The thermometer shall be calibrated annually as a single unit and have a three- or four-wire connection configuration. The sensing element shall be immersed to the depth specified by the manufacturer adjacent to the capillary tube.

NOTE 5—A minimum of 50 mm [2 in.] of the thermometer sheath (wire-connecting side) should not be subjected to the bath medium unless otherwise specified by the manufacturer.

6.2.3 A thermistor thermometer with sensor, which conforms to the requirements of Specification [E879](#), calibrated annually as a single unit. The sensing element of the thermistor shall be completely immersed in the bath adjacent to the capillary tube.

6.2.3.1 Thermistor thermometers used with testing temperatures greater than 100 °C shall be standardized as a single unit every three months.

NOTE 6—The use of the thermometric devices specified in [6.2.2](#) and [6.2.3](#) are understood to introduce bias in the precision in this method. Also, see Guide [D8055](#) for further guidance for appropriate sensor types.

6.3 *Bath*—A bath suitable for immersion of the viscometer so that the liquid reservoir or the top of the capillary, whichever is uppermost, is at least 20 mm below the upper bath level, and with provisions for visibility of the viscometer and the thermometer. Firm supports for the viscometer shall be provided, or the viscometer may be an integral part of the bath. The efficiency of the stirring and the balance between heat losses and heat input must be such that the temperature of the bath medium does not vary by more than ± 0.03 °C [± 0.05 °F] over the length of the viscometer, or from viscometer to viscometer in the various bath positions at 60 °C [140 °F].

NOTE 7—Distilled water is a suitable bath liquid for determinations at 60 °C [140 °F]. USP White Oil with a flash point above 215 °C [420 °F] has been found suitable for determinations at 135 °C [275 °F]. The flash

point is determined in accordance with Test Method [D92](#).

6.4 *Timer*—A stopwatch or other timing device, graduated in divisions of 0.1 s or less and accurate to within 0.05 % when tested over intervals of not less than 15 min. Timing devices for this test method must be standardized at least every twelve months.

6.4.1 *Electrical Timing Devices* may be used only on electrical circuits, the frequencies of which are controlled to an accuracy of 0.05 % or better.

6.4.1.1 Alternating currents, the frequencies of which are intermittently and not continuously controlled, as provided by some public power systems, can cause large errors, particularly over short timing intervals, when used to actuate electrical timing devices.

7. Preparation of Sample

7.1 To minimize loss of volatile constituents and to obtain reproducible results, proceed as follows:

7.1.1 *Procedure for Liquid Asphalts, Distillation Residues, and Road Oil:*

7.1.1.1 Allow sealed samples, as received, to reach room temperature.

7.1.1.2 Open the sample container and mix the sample thoroughly by stirring for 30 s, taking care to avoid the entrapment of air. If the sample is too viscous for such stirring, place the sample in the tightly sealed container in a bath or oven maintained at 63 ± 3 °C [145 ± 5 °F] until it becomes sufficiently liquid for stirring.

7.1.1.3 Immediately charge the viscometer, or, if the test is to be made at a later time, pour approximately 20 mL into one or more clean, dry containers having a capacity of approximately 30 mL and immediately seal with an airtight closure.

7.1.1.4 For materials with kinematic viscosities at 60 °C [140 °F] above 800 mm²/s [cSt], heat the 20 mL sample in the sealed container in an oven or bath maintained at 63 ± 3 °C [145 ± 5 °F] until it is sufficiently liquid for a convenient transfer into the viscometer. Such heating should not exceed 30 min.

7.1.2 *Procedure for Liquid Asphalts and Distillation Residues in the Range from 6 to 100 000 mm²/s [cSt]:*

7.1.2.1 Heat the sample with care to prevent local overheating until it has become sufficiently fluid to pour, occasionally stirring the sample to aid heat transfer and to ensure uniformity.

7.1.2.2 Transfer a minimum of 20 mL into a suitable container and heat to 135 ± 5.5 °C [275 ± 10 °F], stirring occasionally to prevent local overheating and taking care to avoid the entrapment of air.

8. Procedure

8.1 The specific details of operation vary somewhat for the various types of viscometers. See the detailed descriptions of viscometers in [Annex A2](#) for instructions for using the type of viscometer selected. In all cases, however, follow the general procedure described in [8.2 – 8.8](#).

8.1.1 The specific details of operation for automated viscometers will vary from the manual procedure described in [8.4](#), [8.6](#), and [8.8](#). Refer to the operating instructions provided by the automated viscometer manufacturer.

8.2 Maintain the bath at the test temperature within ± 0.01 °C [± 0.02 °F]. Apply the necessary corrections, if any, to all thermometer readings.

8.3 Select a clean, dry viscometer which will give an efflux time greater than 60 s and preheat to test temperature.

8.4 Charge the viscometer in the manner dictated by the design of the instrument, as prescribed in [Annex A2](#).

8.5 Allow the charged viscometer to remain in the bath long enough to reach the test temperature, as prescribed in [Annex A2](#).

8.6 Start the flow of asphalt in the viscometer as prescribed in [Annex A2](#).

8.7 Measure to within 0.1 s the time required for the leading edge of the meniscus to pass from the first timing mark to the second. If this efflux time is less than 60 s, select a viscometer of smaller capillary diameter and repeat the operation.

8.8 Upon completion of the test, clean the viscometer thoroughly by several rinsings with an appropriate solvent completely miscible with the sample, followed by a completely volatile solvent. Dry the tube by passing a slow stream of filtered dried air through the capillary for 2 min, or until the last trace of solvent is removed. Alternatively, the viscometer may be cleaned in a glass cleaning oven at a temperature not to exceed 500 °C [932 °F], followed by rinses with distilled or deionized water, residue-free acetone, and filtered dry air. Periodically, if deposits are observed, clean the instrument with a strong acid cleaning solution to remove organic deposits, rinse thoroughly with distilled water and residue-free acetone, and dry with filtered dry air.

NOTE 8—The cleaning oven may burn off the glue that connects the viscometer tube to the holder.

8.8.1 Chromic acid cleaning solution may be prepared by adding, with the usual precautions, 800 mL of concentrated sulphuric acid to a solution of 92 g of sodium dichromate in 458 mL of water. The use of similar commercially available sulphuric acid cleaning solutions is acceptable. Nonchromium-containing, strongly oxidizing acid cleaning solutions may be substituted so as to avoid the disposal problems of chromium-containing solutions.

8.8.2 Use of alkaline glass-cleaning solutions may result in a change of viscometer calibration, and is not recommended.

9. Calculation

9.1 Calculate the kinematic viscosity to three significant figures using the following equation:

$$\text{Kinematic viscosity, mm}^2/\text{s [cSt]} = Ct \quad (1)$$

where:

C = calibration constant of the viscometer, mm^2/s^2 [cSt/s], and

t = efflux time, s.

NOTE 9—Other ASTM publications on viscosity that may be used in conjunction with results determined in accordance with this test method are Test Method [D445](#), Practices [D2493/D2493M](#) and [D341](#), and Specification [D446](#).

10. Report

10.1 Always report the test temperature with the result, for example:

$$\text{Kinematic viscosity at } 60 \text{ }^\circ\text{C} = 75.6 \text{ mm}^2/\text{s [cSt]} \quad (2)$$

11. Precision and Bias

11.1 Criteria for judging the acceptability of viscosity test results obtained by this method are given in [Tables 1 and 2](#).

TABLE 1 Acceptability of Test Results for Kinematic Viscosity for Liquid Asphalts at 60 °C^A

NOTE 1—The values given in Column 2 are the coefficients of variation that have been found to be appropriate for the materials and conditions of test described in Column 1. The values given in Column 3 are the limits that should not be exceeded by the difference between the results of two properly conducted tests.

Material and Type Index	Coefficient of Variation (% of mean) ^B	Acceptable Range of Two Results (% of mean) ^B
Single-operator precision:		
Liquid asphalts at 60 °C [140 °F]:		
below 3000 mm ² /s [cSt]	0.53	1.5
3000 to 6000 mm ² /s [cSt]	0.71	2.0
6000 mm ² /s [cSt] and above	3.2	8.9
Multilaboratory precision:		
Liquid asphalts at 60 °C [140 °F]:		
below 3000 mm ² /s [cSt]	1.06	3.0
3000 to 6000 mm ² /s [cSt] ^C	3.11	9.0
above 6000 mm ² /s [cSt] ^C	3.6	10.0

^A Supporting data and information for determining these estimates can be found in Manning, R. E., "Comments on Vacuum Viscometers for Measuring the Viscosity of Asphalt Cements," *Symposium on Fundamental Viscosity of Bituminous Materials*, ASTM STP 328, ASTM International, 1963, pp. 44–47.

^B These numbers represent, respectively, the (1s %) and (d2s %) limits as described in Practice [C670](#).

^C Based on less than 30 degrees of freedom.

TABLE 2 Acceptability of Test Results for Kinematic Viscosity for Liquid Asphalts at 135 °C

NOTE 1—The values given in Column 2 are the coefficients of variation that have been found to be appropriate for the materials and conditions of test described in Column 1. The values given in Column 3 are the limits that should not be exceeded by the difference between the results of two properly conducted tests.

Material and Type Index	Coefficient of Variation (% of mean) ^A	Acceptable Range of Two Results (% of mean) ^A
Single-operator precision:		
Unconditioned liquid asphalts at 135 °C [275 °F]	1.64	4.64
Rolling thin-film oven conditioned liquid asphalts at 135 °C [275 °F]	2.08	5.89
Multilaboratory precision:		
Unconditioned liquid asphalts at 135 °C [275 °F]	3.4	9.6
Rolling thin-film oven conditioned liquid asphalts at 135 °C [275 °F]	4.58	12.9

^A These numbers represent, respectively, the (1s%) and (d2s%) limits as described in Practice [C670](#).

NOTE 10—The precision of this test method is only known for manual reverse-flow kinematic viscometers. In Test Method [D445](#), automated kinematic viscometers have been shown to have precisions no worse than

manual viscometers across a range of different materials.

11.2 The precision of this test method outlined in **Table 2** is based on an interlaboratory study of ASTM D2170/D2170M, Test Method for Kinematic Viscosity of Asphalts, conducted from 2015 to 2019. Ninety-three volunteer laboratories were asked to test nine different materials. Every “test result” represents an individual determination, and all participants were instructed to report two replicate test results for each material. Practice **E691** was followed for the design of study and analysis of the data; the details are given in ASTM Research Report No RR:D04-2001.³

³ Supporting data have been filed at ASTM International Headquarters and may be obtained by requesting Research Report RR:D04-2001. Contact ASTM Customer Service at service@astm.org.

11.2.1 The precision statement was determined through statistical examination of 2946 results, from 93 laboratories, on nine unmodified materials. The viscosities for the nine materials ranged from 170 cSt to 532 cSt.

11.3 *Bias*—At the time of the study, there was no accepted reference material suitable for determining the bias for this test method; therefore, no statement on bias is being made.

12. Keywords

12.1 asphalt; capillary; kinematic; viscometer; viscosity

ANNEXES

(Mandatory Information)

A1. CALCULATION OF VISCOSITY OF A NEWTONIAN LIQUID

A1.1 The viscosity of a Newtonian liquid is calculated from its kinematic viscosity by multiplying the kinematic viscosity by the density of the liquid at the test temperature.

A1.2 For paving-grade asphalts, density at 135 °C [275 °F] can be conveniently determined from specific gravity at 25/25 °C [77/77 °F] by multiplying by a factor of 0.934 g/cm³; or from the specific gravity at 15.5/15.5 °C [60/60 °F] by multiplying by a factor of 0.931 g/cm³. These factors are based on an average coefficient of expansion for asphalt cement of 0.00061/°C [0.00034/°F].

A1.3 When the specific gravity of the asphalt is not known, a satisfactory determination of the viscosity at 135 °C [275 °F] can be obtained by multiplying the kinematic viscosity at 135 °C [275 °F] by an assumed density of 0.948 g/cm³. This density value is equivalent to a specific gravity of 1.015 at 25/25 °C [77/77 °F]. Tests on a large number of asphalts indicate that the error introduced by this assumed density will not exceed ±3 %.

A2. REVERSE-FLOW VISCOMETERS

A2.1 Scope

A2.1.1 The reverse-flow viscometers for transparent and opaque liquids include the Cannon-Fenske Opaque,⁴ Zeitfuchs Cross-Arm,⁵ BS/IP/RF, and Lantz-Zeitfuchs viscometers. Unlike the modified Ostwald and suspended-level viscometers, the sample of liquid flows into a timing bulb not previously wet by sample, thus allowing the timing of liquids whose thin films

are opaque. Reverse-flow viscometers are used for the measurement of kinematic viscosities of opaque and transparent liquids up to 100 000 mm²/s [cSt].

A2.2 Apparatus

A2.2.1 For the reverse-flow viscometers, detailed drawings of the size designations, approximate constants, kinematic viscosity range, capillary diameter, and bulb volumes for each viscometer are shown in **Figs. A2.1-A2.4**. The kinematic viscosity range is based on a 60 s minimum flow time in this method; the same viscometers are also described in Specification **D446** with a different viscosity range based on a 200 s

⁴ Cannon, M. R., and Fenske, M. R., “Viscosity Measurement—Opaque Liquids,” *Industrial and Engineering Chemistry*, Analytical Edition, Vol 13, 1941, p. 2910.

⁵ Zeitfuchs, E. H., “Kinematic Viscometer for Opaque and Very Viscous Liquids,” *Oil and Gas Journal*, Vol 44, No. 36, 1946, p. 98.

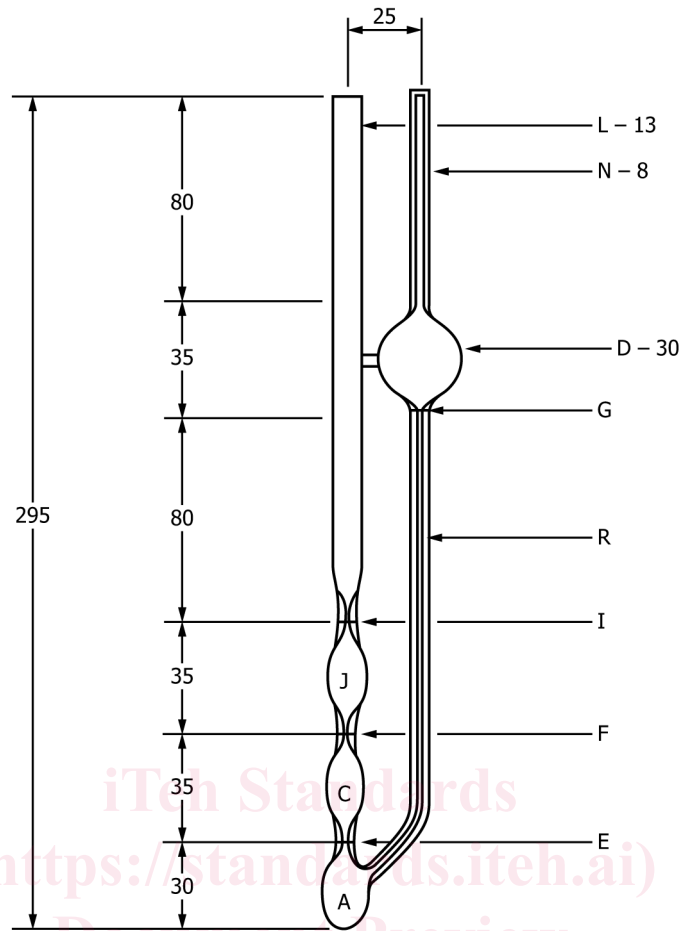

Dimensions and Kinematic Viscosity Ranges

Size No.	Approximate Constant, mm ² /s [cSt/s]	Kinematic Viscosity Range, mm ² /s [cSt]	Inside Diameter of Tube, R, mm (±2 %)	Inside Diameter of Tube N and G Tubes E, F, and I, mm (±5 %)	Volume Bulbs A, C, and J, mL (±5 %)	Volume Bulb D, mL (±5 %)
200	0.1	6 to 100	1.02	3.2	2.1	11
300	0.25	15 to 250	1.26	3.4	2.1	11
350	0.5	30 to 500	1.48	3.4	2.1	11
400	1.2	72 to 1200	1.88	3.4	2.1	11
450	2.5	150 to 2500	2.20	3.7	2.1	11
500	8	480 to 8000	3.10	4.0	2.1	11
600	20	1200 to 20 000	4.00	4.7	2.1	13

NOTE 1—All dimensions are in millimetres.

FIG. A2.1 Cannon-Fenske Opaque Viscometer for Opaque and Transparent Liquids

minimum flow time as prescribed in Test Method D445. The lengths of the upper tubes K, L, M, and N in Figs. A2.1-A2.4 may be increased (or decreased) to conform to the immersion requirements of 6.3.

A2.3 Operating Instructions

A2.3.1 A standard operating procedure is contained in Section 7. Additional operating instructions for the reverse-flow viscometers are outlined in A2.3.2 – A2.3.8 with emphasis on procedures that are specific to a particular instrument or this group of instruments.

A2.3.2 Select a clean, dry viscometer that will give a flow time greater than 60 s.

A2.3.3 Charge the viscometer in the manner dictated by the design of the instrument, this operation being in conformity with that employed when the instrument was calibrated. If the sample may contain lint, solid particles, etc., filter as prescribed in Test Method D445.

A2.3.3.1 To charge the Cannon-Fenske Opaque viscometer, invert the viscometer and apply suction to the tube L, immersing tube N in the liquid sample. Draw liquid through tube N,