INTERNATIONAL STANDARD



5698

INTERNATIONAL ORGANIZATION FOR STANDARDIZATION • МЕЖДУНАРОДНАЯ ОРГАНИЗАЦИЯ ПО СТАНДАРТИЗАЦИИ • ORGANISATION INTERNATIONALE DE NORMALISATION

Agricultural machinery — Hoppers — Manual loading height

Matériel agricole — Trémies — Hauteur de chargement manuel

First edition — 1979-04-01

ITeh STANDARD PREVIEW
(standards.iteh.ai)

ISO 5698:1979

<https://standards.iteh.ai/catalog/standards/sist/b1b2ee79-d85b-4e3c-a21e-2a1c54306e42/iso-5698-1979>

UDC 631.3.021

Ref. No. ISO 5698-1979 (E)

Descriptors : agricultural machinery, hoppers, loading, dimensions, height, hand reach.

FOREWORD

ISO (the International Organization for Standardization) is a worldwide federation of national standards institutes (ISO member bodies). The work of developing International Standards is carried out through ISO technical committees. Every member body interested in a subject for which a technical committee has been set up has the right to be represented on that committee. International organizations, governmental and non-governmental, in liaison with ISO, also take part in the work.

Draft International Standards adopted by the technical committees are circulated to the member bodies for approval before their acceptance as International Standards by the ISO Council.

International Standard ISO 5698 was developed by Technical Committee ISO/TC 23, *Tractors and machinery for agriculture and forestry*, and was circulated to the member bodies in January 1978.

(standards.iteh.ai)

It has been approved by the member bodies of the following countries :

Australia	India	Spain
Austria	Iran	Sweden
Belgium	Ireland	Switzerland
Bulgaria	Italy	Turkey
Canada	Korea, Dem. P. Rep. of	United Kingdom
Chile	Mexico	USA
Denmark	New Zealand	USSR
Finland	Poland	Yugoslavia
France	Romania	
Germany, F.R.	South Africa, Rep. of	

<https://standards.iteh.ai/catalog/standards/sist/b1b2ee79-d85b-4e3c-a21e-2a1c5436e42/iso-5698-1979>

The member body of the following country expressed disapproval of the document on technical grounds :

Czechoslovakia

Agricultural machinery — Hoppers — Manual loading height

1 SCOPE

This International Standard specifies a height for manual loading for agricultural machines fitted with hoppers, and the minimum dimensions of any ancillary steps or platform.

2 FIELD OF APPLICATION

This International Standard applies to agricultural machines equipped with hoppers, for distributing items such as fertilizers or seeds, into which the materials are manually loaded from bags.

3 DEFINITIONS

3.1 loading height: The maximum height above a stated datum level at which the goods are placed in the hopper of the machine.

3.2 datum level: Either the ground level (mainly applying to smaller mounted implements), a step, or a loading platform.

4 REQUIREMENTS

4.1 Maximum loading height

The maximum loading height of an agricultural machine above a specified datum level shall be such that an operator carrying bagged goods (for example a sack of fertilizer) may conveniently empty them into the hopper of the machine. This height shall not exceed 1 250 mm (see figures 1 and 2).

4.2 Height of step or loading platform

Where a step or loading platform is fitted to the machine, it shall be not more than 300 mm vertically above the ground or another step or loading platform.

NOTES

1 All classes of machine covered by this International Standard should be constructed so as to allow the hopper to be placed immediately adjacent to a trailer, loading dock or stack to ease manual loading.

2 In the case of mounted fertilizer centrifuges, which are often loaded from stacks of bagged fertilizer placed at intervals around the perimeter of the field, it is recommended that the datum level in this case should be ground level. Where the top of the hopper of a mounted broadcaster is higher than the recommended level when the machine is in its working position, it should be possible to lower the machine on the three-point linkage of the tractor, until the hopper height complies with the standard.

3 Minimum dimensions for the steps for the loading platform are given in figure 2.

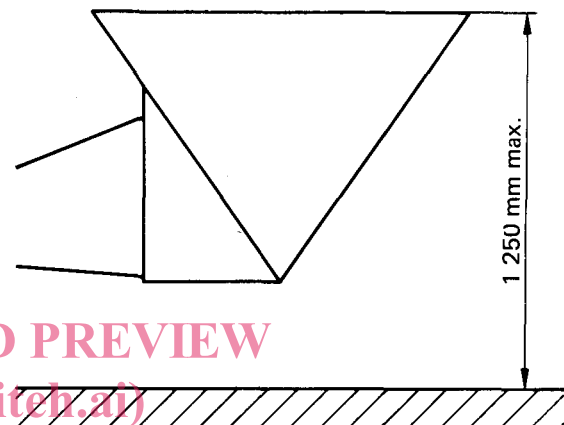

FIGURE 1 — Mounted implements

Dimensions in millimetres

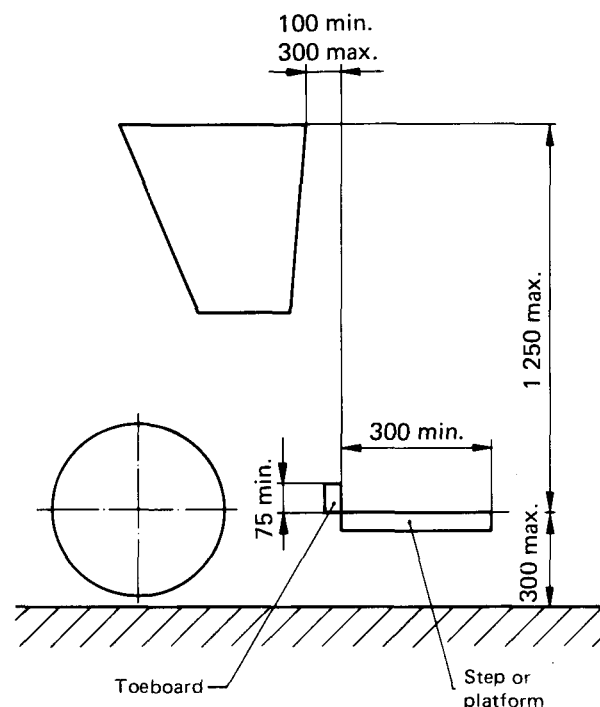

FIGURE 2 — Trailed implements

iTeh STANDARD PREVIEW
(standards.iteh.ai)

ISO 5698:1979

<https://standards.iteh.ai/catalog/standards/sist/b1b2ee79-d85b-4e3c-a21e-2a1c54306e42/iso-5698-1979>