



SLOVENSKI STANDARD

SIST ISO 5718-2:1995

01-april-1995

Oprema za žetev - Ravni noži za rotacijske kosilnice - 2. del: Specifikacija za ravne nože tipa B

Harvesting equipment -- Flat blades for rotary mowers -- Part 2: Specifications for type B flat blades

iTeh STANDARD PREVIEW

Matériel de récolte -- Lames plates pour faucheuses rotatives -- Partie 2: Spécifications pour lames plates du type B

Ta slovenski standard je istoveten z: **ISO 5718-2:1991**

ICS:

65.060.50 Oprema za spravilo pridelkov Harvesting equipment

SIST ISO 5718-2:1995

en

iTeh STANDARD PREVIEW
(standards.iteh.ai)

SIST ISO 5718-2:1995

<https://standards.iteh.ai/catalog/standards/sist/b75d5088-9de0-44fb-9235-8172c5fad7e0/sist-iso-5718-2-1995>

INTERNATIONAL STANDARD

ISO
5718-2

First edition
1991-06-15

Harvesting equipment — Flat blades for rotary mowers —

Part 2:

Specifications for type B flat blades
(standards.iteh.ai)

Matériel de récolte — Lames plates pour faucheuses rotatives —

Partie 2: Spécifications pour lames plates du type B
<https://standards.iteh.ai/catalog/standards/sist/5718-2-1995/iso-5718-2-1995>
8172c5fad7e0/sist-iso-5718-2-1995



Reference number
ISO 5718-2:1991(E)

ISO 5718-2:1991(E)

Foreword

ISO (the International Organization for Standardization) is a worldwide federation of national standards bodies (ISO member bodies). The work of preparing International Standards is normally carried out through ISO technical committees. Each member body interested in a subject for which a technical committee has been established has the right to be represented on that committee. International organizations, governmental and non-governmental, in liaison with ISO, also take part in the work. ISO collaborates closely with the International Electrotechnical Commission (IEC) on all matters of electrotechnical standardization.

Draft International Standards adopted by the technical committees are circulated to the member bodies for voting. Publication as an International Standard requires approval by at least 75 % of the member bodies casting a vote.

International Standard ISO 5718-2 was prepared by Technical Committee ISO/TC 23, *Tractors and machinery for agriculture and forestry*.

ISO 5718 consists of the following parts, under the general title *Harvesting equipment — Flat blades for rotary mowers*:

- Part 1: *Specifications for type A flat blades*
- Part 2: *Specifications for type B flat blades*

© ISO 1991

All rights reserved. No part of this publication may be reproduced or utilized in any form or by any means, electronic or mechanical, including photocopying and microfilm, without permission in writing from the publisher.

International Organization for Standardization
Case Postale 56 • CH-1211 Genève 20 • Switzerland

Printed in Switzerland

Harvesting equipment — Flat blades for rotary mowers —

Part 2: Specifications for type B flat blades

1 Scope

This part of ISO 5718 lays down the specifications for type B flat blades used on agricultural rotary mowers for harvesting. It specifies main dimensions and resistance to failure by bending of such blades.

NOTES

1 The main purpose of ISO 5718 is to ensure operational safety and interchangeability of flat blades. Flat blades on rotary mowers are exposed to considerable centrifugal forces and impacts with foreign objects. A simple bend test to check the brittleness of material is therefore included in this part of ISO 5718.

2 Two types of rotary mower are defined in ISO 5718-1.

2 Normative reference

The following standard contains provisions which, through reference in this text, constitute provisions of this part of ISO 5718. At the time of publication,

the edition indicated was valid. All standards are subject to revision, and parties to agreements based on this part of ISO 5718 are encouraged to investigate the possibility of applying the most recent edition of the standard indicated below. Members of IEC and ISO maintain registers of currently valid International Standards.

ISO 2768-1:1989, *General tolerances — Part 1: Tolerances for linear and angular dimensions without individual tolerance indications.*

3 Dimensions

Dimensions of type B flat blades shall comply with figure 1 and table 1. Where no tolerance is indicated, dimensions shall be to the tolerances given in ISO 2768-1.

Dimensions in millimetres

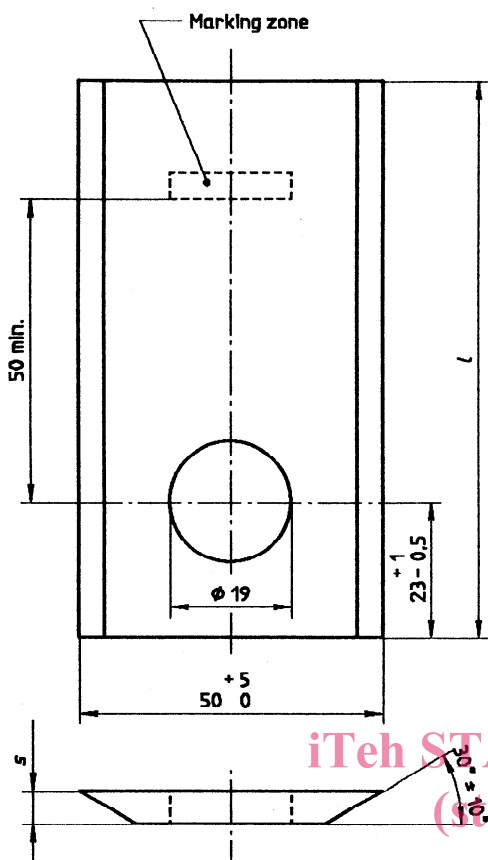

Figure 1 — Type B flat blade dimensions

Table 1
Dimensions in millimetres

l	s +0,3 -0,2
105	4
125	5
150	

4 Material requirements

4.1 Requirements

The resistance to failure by bending shall meet the test requirements in 4.2. After the bend test, the blade shall not present any visible cracks or fissures.

4.2 Bend test

Clamp a blade over a length of 35 mm (see figure 2) and bend it progressively around an inside radius R of 16 mm by means of a rolling device through an angle α (see table 2).

A spring-back rate is not taken into account.

Dimensions in millimetres

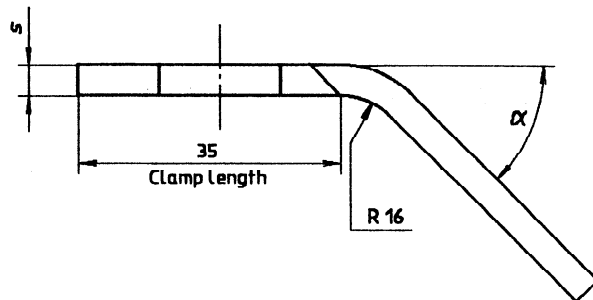

Figure 2 — Bend test

Table 2

s mm	α
4	45°
5	30°

5 Designation example

A type B flat blade for rotary mowers that meets the requirements of this part of ISO 5718, with overall length 125 mm and a thickness of 5 mm, shall be designated as follows:

Flat blade ISO 5718-2 B 125 × 5

6 Marking

Inside the marking zone on each blade (see figure 1) the type, length and thickness of the blade and the name or trademark of the manufacturer shall be indicated. These indications and in addition the number of this part, ISO 5718-2, shall be labelled on the outside of the packing.