

INTERNATIONAL STANDARD

IEC
60917-2-3

First edition
2006-05

**Modular order for the development
of mechanical structures
for electronic equipment practices –**

**Part 2-3:
Sectional specification –
Interface co-ordination dimensions
for the 25 mm equipment practice –
Extended detail specification –
Dimensions for subracks, chassis, backplanes,
front panels and plug-in units**

[IEC 60917-2-3:2006](https://standards.iteh.ai/catalog/standards/iec/b108e261-ee5b-4fed-b4ce-3c76e6adb91b/iec-60917-2-3-2006)

<https://standards.iteh.ai/catalog/standards/iec/b108e261-ee5b-4fed-b4ce-3c76e6adb91b/iec-60917-2-3-2006>



Reference number
IEC 60917-2-3:2006(E)

Publication numbering

As from 1 January 1997 all IEC publications are issued with a designation in the 60000 series. For example, IEC 34-1 is now referred to as IEC 60034-1.

Consolidated editions

The IEC is now publishing consolidated versions of its publications. For example, edition numbers 1.0, 1.1 and 1.2 refer, respectively, to the base publication, the base publication incorporating amendment 1 and the base publication incorporating amendments 1 and 2.

Further information on IEC publications

The technical content of IEC publications is kept under constant review by the IEC, thus ensuring that the content reflects current technology. Information relating to this publication, including its validity, is available in the IEC Catalogue of publications (see below) in addition to new editions, amendments and corrigenda. Information on the subjects under consideration and work in progress undertaken by the technical committee which has prepared this publication, as well as the list of publications issued, is also available from the following:

- **IEC Web Site** (www.iec.ch)

- **Catalogue of IEC publications**

The on-line catalogue on the IEC web site (www.iec.ch/searchpub) enables you to search by a variety of criteria including text searches, technical committees and date of publication. On-line information is also available on recently issued publications, withdrawn and replaced publications, as well as corrigenda.

- **IEC Just Published**

This summary of recently issued publications (www.iec.ch/online_news/justpub) is also available by email. Please contact the Customer Service Centre (see below) for further information.

- **Customer Service Centre**

If you have any questions regarding this publication or need further assistance, please contact the Customer Service Centre: _____

Email: custserv@iec.ch

Tel: +41 22 919 02 11

Fax: +41 22 919 03 00

INTERNATIONAL STANDARD

IEC 60917-2-3

First edition
2006-05

Modular order for the development of mechanical structures for electronic equipment practices –

Part 2-3: Sectional specification – Interface co-ordination dimensions for the 25 mm equipment practice – Extended detail specification – Dimensions for subracks, chassis, backplanes, front panels and plug-in units

<https://standards.iteh.ai/catalog/standards/iec/b108e261-ee5b-4fed-b4ce-3c76e6adb91b/iec-60917-2-3-2006>

<https://standards.iteh.ai/catalog/standards/iec/b108e261-ee5b-4fed-b4ce-3c76e6adb91b/iec-60917-2-3-2006>

© IEC 2006 — Copyright - all rights reserved

No part of this publication may be reproduced or utilized in any form or by any means, electronic or mechanical, including photocopying and microfilm, without permission in writing from the publisher.

International Electrotechnical Commission, 3, rue de Varembé, PO Box 131, CH-1211 Geneva 20, Switzerland
Telephone: +41 22 919 02 11 Telefax: +41 22 919 03 00 E-mail: inmail@iec.ch Web: www.iec.ch



Commission Electrotechnique Internationale
International Electrotechnical Commission
Международная Электротехническая Комиссия

PRICE CODE

V

For price, see current catalogue

CONTENTS

FOREWORD.....	4
INTRODUCTION.....	6
1 Scope and object.....	8
2 Normative references	8
3 Terms and definitions	9
4 Arrangement overview.....	9
5 Subrack dimensions for injector/extractor handle of plug-in units.....	10
5.1 Subrack interface dimensions.....	10
6 Dimensions of injector/extractor handle for plug-in units	12
6.1 Injector/extractor handle interface dimensions.....	12
6.2 Handle-locking function	14
7 Subrack and plug-in units with electromagnetic shielding provision	14
7.1 Subrack interface dimensions for electromagnetic shielding provision	14
7.2 Front panel/plug-in unit interface dimensions	17
8 Key/coding system for subrack and plug-in units	18
8.1 Subrack interface dimensions – Key/coding system on the plug-in unit guides	19
8.2 Key dimensions – Key/coding system on the plug-in unit guides.....	20
8.3 Programming of key – Key/coding system on the plug-in guides.....	22
8.4 Keying chamber inspection dimensions	22
9 Alignment pin and/or electrical contact for front panels and plug-in units	23
9.1 Alignment pins and receptacle plates on the subrack horizontal members	24
9.2 Alignment and/or electrical contact pins and receptacles on the subrack plug-in unit guides.....	25
10 Electrostatic discharge provision for plug-in units and subracks.....	27
10.1 ESD contact interface dimensions	28
10.2 ESD strip interface dimensions.....	28
11 Subrack dimensions for rear-mounted plug-in units	32
 Annex A Subrack, plug-in unit and backplane dimensions for using metric connectors.....	 33
 Figure 1 – Typical example of large subracks in a wide cabinet, equipped mass volume of copper/optical cables installation	 7
Figure 2 – Subject for development of extended connector application packaging and key elements of interconnection between functional plug-in modules via backplane in the future packaging system	7
Figure 3 – Arrangement overview	9
Figure 4 – Subrack interface dimensions, injector/extractor handles for plug-in units	11
Figure 5 – Detail X and detail Y, subrack interface dimensions, injection/extraction handles for plug-in units.....	12
Figure 6 – Plug-in units interface dimensions, injection/extraction handle for plug-in units ...	13
Figure 7 – Detail X and detail Y, plug-in interface dimensions, injector/extractor handles for plug-in units.....	14
Figure 8 – Subrack interface dimensions, electromagnetic shielding provisions	15

Figure 9 – Detail X and detail Y, subrack interface dimensions, electromagnetic shielding provisions	16
Figure 10 – Front panel/plug-in unit interface dimensions, electromagnetic shielding provisions	17
Figure 11 – Arrangement of key/coding system for plug-in units.....	18
Figure 12 – Subrack interface dimensions – Key/coding system on the plug-in unit guides.....	19
Figure 13 – Plug-in unit interface dimensions – Key/coding system on the plug-in unit guides.....	20
Figure 14 – Key dimensions and rotated key positions – Key/coding system on the plug-in unit guides	21
Figure 15 – Programming of keys	22
Figure 16 – Arrangement of alignment pin system for subracks and plug-in units.....	23
Figure 17 – Subrack interface dimensions, alignment pins and receptacle plates on the horizontal members	24
Figure 18 – Plug-in unit interface dimensions, alignment pins and receptacle plates on the horizontal members	25
Figure 19 – Subrack interface dimensions, alignment and/or electrical contact pin receptacles on the plug-in unit guides.....	26
Figure 20 – Plug-in unit interface dimensions, alignment and/or electrical contact pin receptacles on the plug-in unit guides.....	27
Figure 21 – Subrack interface dimensions, ESD contacts on the plug-in guides	28
Figure 22 – Plug-in unit interface dimensions, ESD strips on the plug-in boards	29
Figure 23 – Subrack dimensions for rear mounted plug-in units	32
Figure A.1 – Subrack, plug-in unit and backplane dimensions for using 2,5 mm metric connectors in accordance with IEC 61076-4-100.....	33
Figure A.2 – Subrack, plug-in unit and backplane dimensions for using 2 mm metric connectors in accordance with IEC 61076-4-101.....	34
Figure A.3 – Subrack, plug-in unit and backplane dimensions for using 2 mm metric connectors in accordance with IEC 61076-4-104.....	35
Table 1 – Inspection dimensions of subrack and plug-in unit keying chambers.....	22
Table 2 – Dimensions of subracks and plug-in units based on IEC 60917-2-2.....	30
Table 3 – Dimensions of subracks and boards for rear-mounted plug-in units	32

INTERNATIONAL ELECTROTECHNICAL COMMISSION

**MODULAR ORDER FOR THE DEVELOPMENT
OF MECHANICAL STRUCTURES
FOR ELECTRONIC EQUIPMENT PRACTICES –**

**Part 2-3: Sectional specification – Interface co-ordination dimensions
for the 25 mm equipment practice – Extended detail specification –
Dimensions for subracks, chassis, backplanes, front panels
and plug-in units**

FOREWORD

- 1) The International Electrotechnical Commission (IEC) is a worldwide organization for standardization comprising all national electrotechnical committees (IEC National Committees). The object of IEC is to promote international co-operation on all questions concerning standardization in the electrical and electronic fields. To this end and in addition to other activities, IEC publishes International Standards, Technical Specifications, Technical Reports, Publicly Available Specifications (PAS) and Guides (hereafter referred to as "IEC Publication(s)"). Their preparation is entrusted to technical committees; any IEC National Committee interested in the subject dealt with may participate in this preparatory work. International, governmental and non-governmental organizations liaising with the IEC also participate in this preparation. IEC collaborates closely with the International Organization for Standardization (ISO) in accordance with conditions determined by agreement between the two organizations.
- 2) The formal decisions or agreements of IEC on technical matters express, as nearly as possible, an international consensus of opinion on the relevant subjects since each technical committee has representation from all interested IEC National Committees.
- 3) IEC Publications have the form of recommendations for international use and are accepted by IEC National Committees in that sense. While all reasonable efforts are made to ensure that the technical content of IEC Publications is accurate, IEC cannot be held responsible for the way in which they are used or for any misinterpretation by any end user.
- 4) In order to promote international uniformity, IEC National Committees undertake to apply IEC Publications transparently to the maximum extent possible in their national and regional publications. Any divergence between any IEC Publication and the corresponding national or regional publication shall be clearly indicated in the latter.
- 5) IEC provides no marking procedure to indicate its approval and cannot be rendered responsible for any equipment declared to be in conformity with an IEC Publication.
- 6) All users should ensure that they have the latest edition of this publication.
- 7) No liability shall attach to IEC or its directors, employees, servants or agents including individual experts and members of its technical committees and IEC National Committees for any personal injury, property damage or other damage of any nature whatsoever, whether direct or indirect, or for costs (including legal fees) and expenses arising out of the publication, use of, or reliance upon, this IEC Publication or any other IEC Publications.
- 8) Attention is drawn to the Normative references cited in this publication. Use of the referenced publications is indispensable for the correct application of this publication.
- 9) Attention is drawn to the possibility that some of the elements of this IEC Publication may be the subject of patent rights. IEC shall not be held responsible for identifying any or all such patent rights.

International Standard IEC 60917-2-3 has been prepared by subcommittee 48D: Mechanical structures for electronic equipment, of IEC technical committee 48: Electromechanical components and mechanical structures for electronic equipment.

The text of this standard is based on following documents:

FDIS	Report on voting
48D/338/FDIS	48D/342/RVD

Full information on the voting for the approval of this standard can be found in the report on voting indicated in the above table.

IEC 60917 consists of the following parts, under the general title *Modular order for the development of mechanical structures for electronic equipment practices*:

- Part 1: Generic standard
- Part 2: Sectional specification – Interface co-ordination dimensions for the 25 mm equipment practice
- Part 2-1: Sectional specification – Interface co-ordination dimensions for the 25 mm equipment practice – Detail specification – Dimensions for cabinets and racks
- Part 2-2: Sectional specification – Interface co-ordination dimensions for the 25 mm equipment practice – Detail specification – Dimensions for subracks, chassis, backplanes, front panels and plug-in units
- Part 2-3: Sectional specification – Interface co-ordination dimensions for the 25 mm equipment practice – Extended detail specification – Dimensions for subracks, chassis, backplanes, front panels and plug-in units

The committee has decided that the contents of this publication will remain unchanged until the maintenance result date indicated on the IEC web site under "<http://webstore.iec.ch>" in the data related to the specific publication. At this date, the publication will be

- reconfirmed;
- withdrawn;
- replaced by a revised edition, or
- amended.

A bilingual version of this publication may be issued at a later date.

iTeh Standards
(<https://standards.itih.ai>)
Document Preview

[IEC 60917-2-3:2006](https://standards.itih.ai/catalog/standards/iec/b108e261-ee5b-4fed-b4ce-3c76e6adb91b/iec-60917-2-3-2006)

<https://standards.itih.ai/catalog/standards/iec/b108e261-ee5b-4fed-b4ce-3c76e6adb91b/iec-60917-2-3-2006>

INTRODUCTION

The dimensions in the detail specification for the 25 mm equipment practice standard are laid down in the IEC 60917-2 series.

Significant progress in electronics circuitry, with increasing signal speed and the demand for high availability of the electronics systems, has made an impact on the structural parts of the equipment, as specified in IEC 60917-2-2.

a) Considerations on the general tendency of the enclosure system

At the moment, the general tendencies of the enclosure system for telecom/IT equipment application and associated application are considered to be:

- the changing form of conventional centralized networking for telecommunication to flexible distributed networking to realize ubiquitous communication and computing environment by broad-band/IP and photonics-networking-based technology;
- flexible configuration of networking equipment from the open market is requested;
- a scalable and high-performance packaging/enclosure system is requested for new networking equipment;
- in addition, such a packaging/enclosure system will be widely applied for general electronic equipment, because IP networking technology is becoming one of the common interfaces for all of industrial systems.

Consequently, the following general requirements for the new enclosure system arise.

- Standard-based but various sized networking/IT equipment from the open market should be installed in one cabinet (see figure 1).
- The mass volume of copper/optical cables from the equipment should be managed in the cabinet.
- Networking/IT cabinets will be increasingly sited at general offices in enterprise buildings rather than at traditional technical rooms in telecom-central offices.

In order to meet these market needs, the implementation of additional specified dimensions for extended features based on IEC 60917-2-2 became necessary.

b) Subject for development of extended connector application packaging based on IEC 60917 series

The existing IEC 60917 series, which is structured on the modular concept of 25 mm, is based on the IEC standardized metric connector. However, the system packaging uses to many non-standardized enhanced connectors, which are necessary to realize the system functions and level of performance (see Figure 2).

NOTE IEC Subcommittee 48D, Working Group 2, reviews the trends in system packaging, in which key elements are electrical/optical signal interfaces and connectors, as well as the general tendency of the new enclosure system. From these aspects, the IEC Subcommittee 48D, Working Group 2 has recently developed IEC 60917-2-3 which will be applicable to system packaging for high-speed and other system applications in the near future.

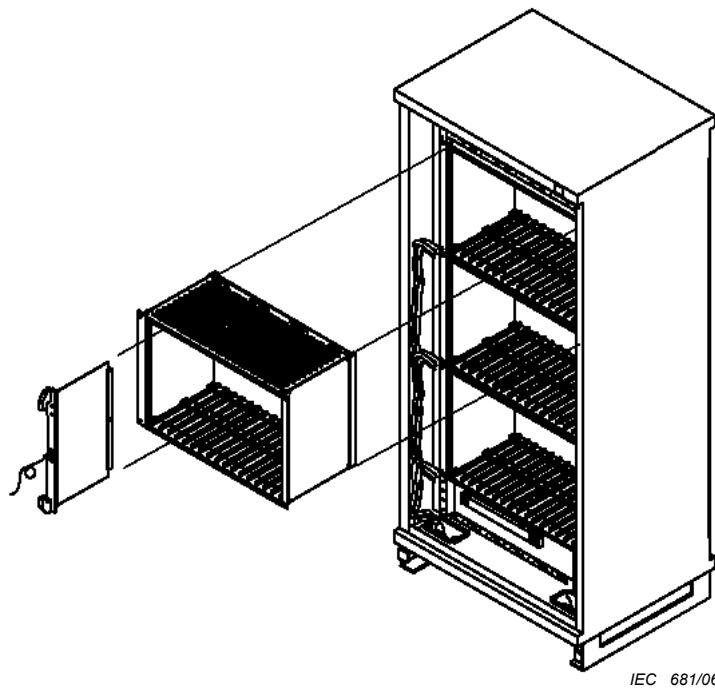
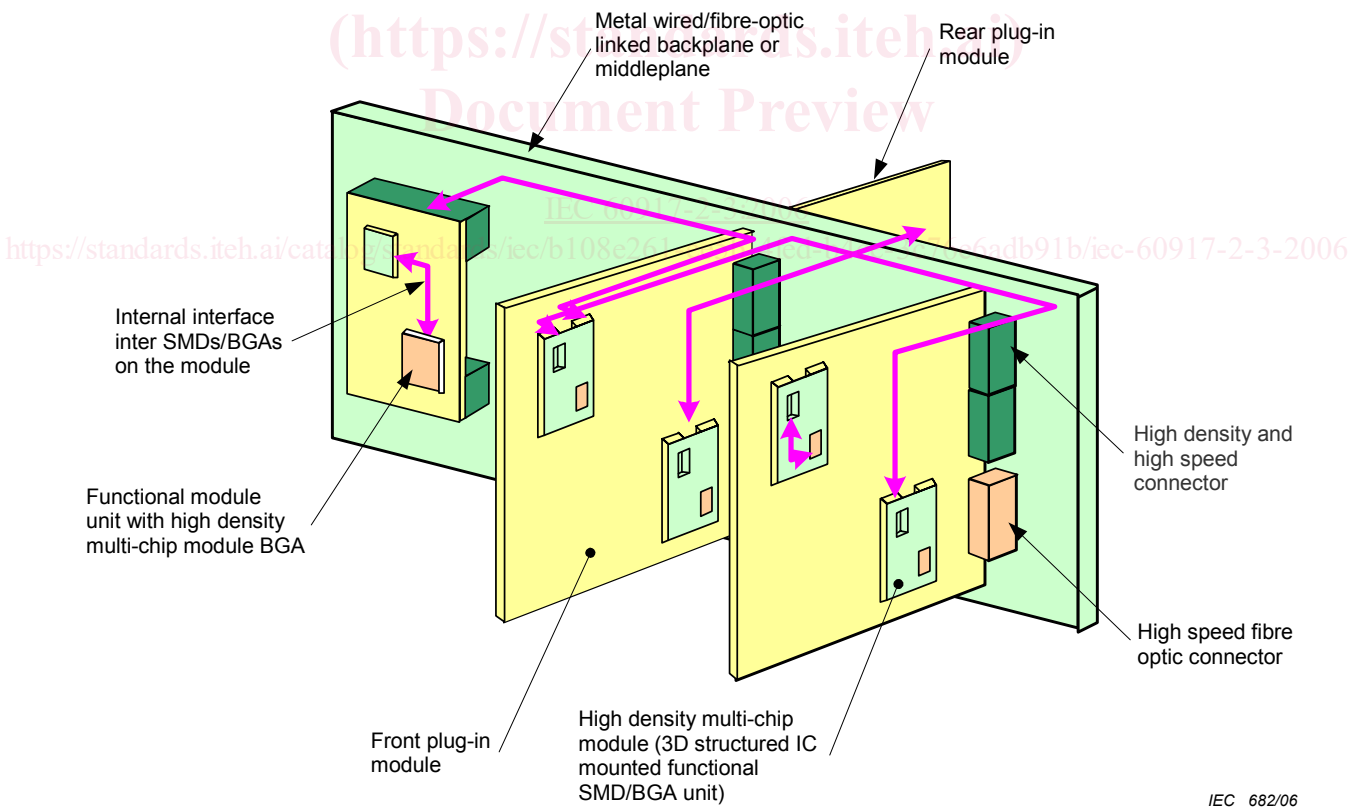

Figure 1 – Typical example of large subracks in a wide cabinet, equipped mass volume of copper/optical cables installation



Key

SMD: Surface Mount Device.

BGA: Ball Grid Array.

Figure 2 – Subject for development of extended connector application packaging and key elements of interconnection between functional plug-in modules via backplane in the future packaging system

MODULAR ORDER FOR THE DEVELOPMENT OF MECHANICAL STRUCTURES FOR ELECTRONIC EQUIPMENT PRACTICES –

Part 2-3: Sectional specification – Interface co-ordination dimensions for the 25 mm equipment practice – Extended detail specification – Dimensions for subracks, chassis, backplanes, front panels and plug-in units

1 Scope and object

This part of IEC 60917 provides additional dimensions for a modular range of subracks and associated plug-in units based on IEC 60917-2-2.

A typical subrack consists of a frame design with mounting dimensions for installation into racks or cabinets in accordance with IEC 60917-2-1. The aperture dimensions of a subrack are specified in order to meet the mounting dimensions of front plug-in units.

This part of IEC 60917 comprises

- additional dimensions for subracks and subrack associated plug-in units with injector/extractor handle;
- dimensions for basic electromagnetic shielding provisions;
- dimensions of the key/coding system for subrack and plug-in units;
- dimensions of the alignment pin for front panel and plug-in unit;
- dimensions of electrostatic discharge provisions;
- dimensions of rear-mounted plug-in units.

Connector-related dimensions are given in Annex A.

In order to ensure the compatibility of plug-in units into the subrack, inspection dimensions and connector-dependent dimensions are defined.

NOTE The drawings used in this part of IEC 60917 are not intended to indicate product design, only the specific dimensions that are used.

2 Normative references

The following referenced documents are indispensable for the application of this document. For dated references, only the edition cited applies. For undated references, the latest edition of the referenced document (including any amendments) applies.

IEC 60917-1:1998, *Modular order for the development of mechanical structures for electronic equipment practices – Part 1: Generic standard*

IEC 60917-2-1:1993, *Modular order for the development of mechanical structures for electronic equipment practice – Part 2: Sectional specification – Interface co-ordination dimensions for the 25 mm equipment practice – Section 1: Detail specification – Dimensions for cabinets and racks*

IEC 60917-2-2:1994, *Modular order for the development of mechanical structures for electronic equipment practice – Part 2: Sectional specification – Interface co-ordination dimensions for the 25 mm equipment practice – Section 2: Detail specification – Dimensions for subracks, chassis, backplanes, front panels and plug-in units*

IEC 61076-4-100:2001, *Connectors for electronic equipment – Part 4-100: Printed board connectors with assessed quality – Detail specification for two-part connector modules having a grid of 2,5 mm for printed boards and backplanes*

IEC 61076-4-101:2001, *Connectors for electronic equipment – Part 4-101: Printed board connectors with assessed quality – Detail specification for two-part connector modules, having a basic grid of 2,0 mm for printed boards and backplane in accordance with IEC 60917*

IEC 61076-4-104:1999, *Connectors for use in d.c., low frequency analogue and digital high speed data application – Part 4-104: Printed board connectors with assessed quality – Detail specification for two-part modular connectors, basic grid of 2,0 mm, with terminations on a multiple grid of 0,5 mm*

3 Terms and definitions

For the purposes of this document, the terms and definitions given in IEC 60917-1 apply.

4 Arrangement overview

Typical subrack with front and rear plug-in units (see Figure 3).

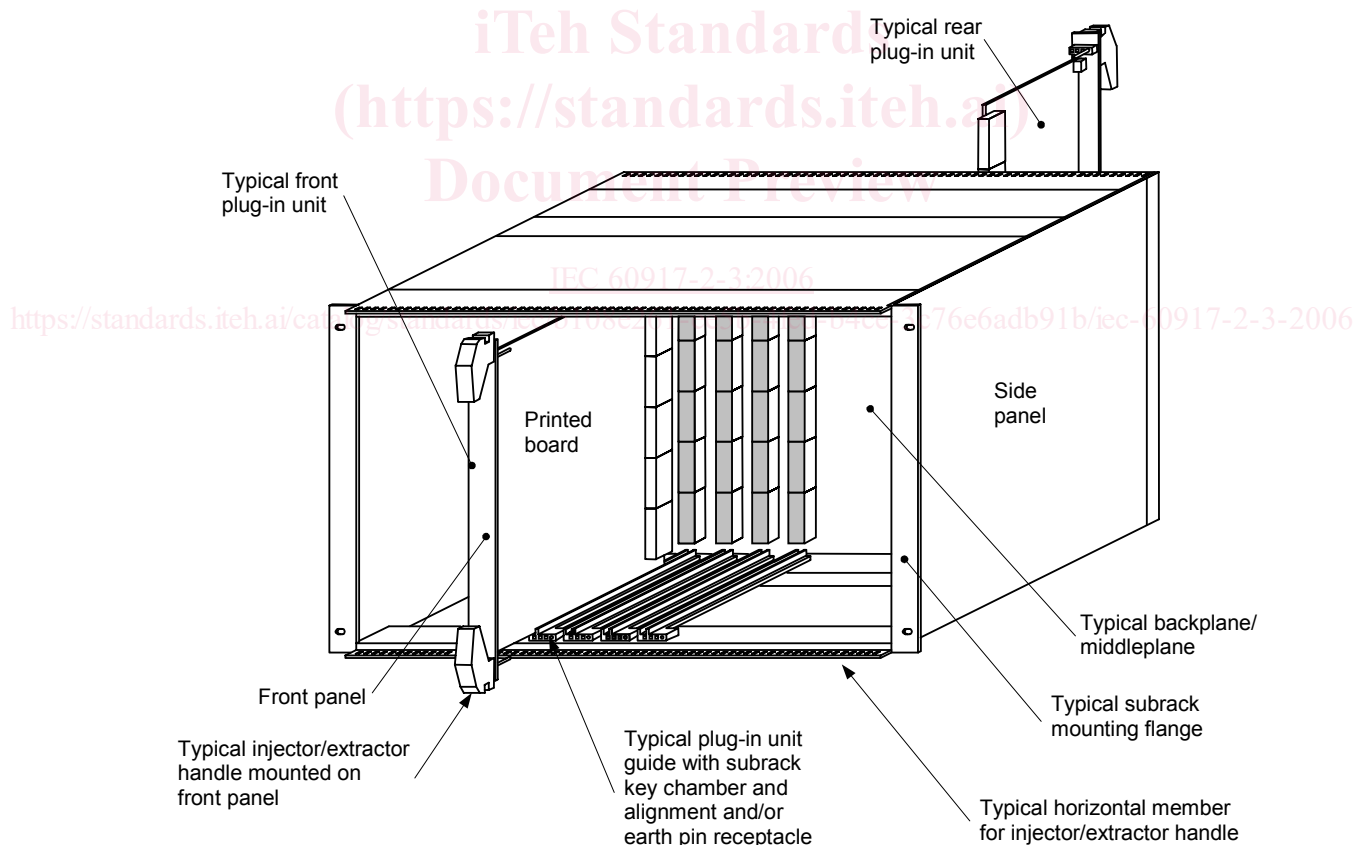

IEC 683/06

Figure 3 – Arrangement overview