

---

# International Standard



# 5821

---

INTERNATIONAL ORGANIZATION FOR STANDARDIZATION • МЕЖДУНАРОДНАЯ ОРГАНИЗАЦИЯ ПО СТАНДАРТИЗАЦИИ • ORGANISATION INTERNATIONALE DE NORMALISATION

---

## Resistance spot welding electrode caps

*Embouts amovibles de pointes d'électrodes pour soudage par points par résistance*

First edition — 1979-12-15

**iTeh STANDARD PREVIEW**  
**(standards.iteh.ai)**

[ISO 5821:1979](https://standards.iteh.ai/catalog/standards/sist/f85e4a90-61cc-42da-a7b5-57ace489ced9/iso-5821-1979)

<https://standards.iteh.ai/catalog/standards/sist/f85e4a90-61cc-42da-a7b5-57ace489ced9/iso-5821-1979>

---

**UDC 621.791.763.1.039**

**Ref. No. ISO 5821-1979 (E)**

**Descriptors :** welding equipment, welding electrodes, resistance welding electrodes, spot welding, dimensions, dimensional tolerances, designation, marking.

## Foreword

ISO (the International Organization for Standardization) is a worldwide federation of national standards institutes (ISO member bodies). The work of developing International Standards is carried out through ISO technical committees. Every member body interested in a subject for which a technical committee has been set up has the right to be represented on that committee. International organizations, governmental and non-governmental, in liaison with ISO, also take part in the work.

Draft International Standards adopted by the technical committees are circulated to the member bodies for approval before their acceptance as International Standards by the ISO Council.

International Standard ISO 5821 was developed by Technical Committee ISO/TC 44, *Welding and allied processes*, and was circulated to the member bodies in July 1978.

It has been approved by the member bodies of the following countries :

Belgium	Germany, F. R.	Mexico
Brazil	India	New Zealand
Bulgaria	Ireland	Norway
Canada	Israel	Poland
Czechoslovakia	Italy	Romania
Egypt, Arab Rep. of	Japan	Spain
France	Korea, Rep. of	USSR

The member bodies of the following countries expressed disapproval of the document on technical grounds :

Sweden  
United Kingdom

# Resistance spot welding electrode caps

## iTeh STANDARD PREVIEW (standards.iteh.ai)

### 1 Scope and field of application

This International Standard lays down the dimensions and tolerances of resistance spot welding electrode caps, where a female taper (see ISO 1089) is used to fix the cap to an electrode adaptor (see ISO 5183).

It applies only to electrode caps for which the electrode force  $F_{\max}$  given for diameter  $d_1$  in the table below is not exceeded.

### 2 References

ISO 1089, *Electrode taper fits for spot welding equipment — Dimensions.*

ISO 5182, *Materials for resistance welding electrodes and ancillary equipment.*

ISO 5183, *Resistance spot welding electrode adaptors.*

### 3 Dimensions

The dimensions shall be as given in the drawings and table.

### 4 Designation

Example of designation of a spot welding electrode cap type A, width  $d_1 = 16$  mm and length  $l_1 = 20$  mm :

Spot welding electrode cap ISO 5821 — A 16 × 20

### 5 Material

ISO 5182 — A 2/2

### 6 Marking

The package shall be marked with the full designation; for example :

ISO 5821 — A 16 × 20

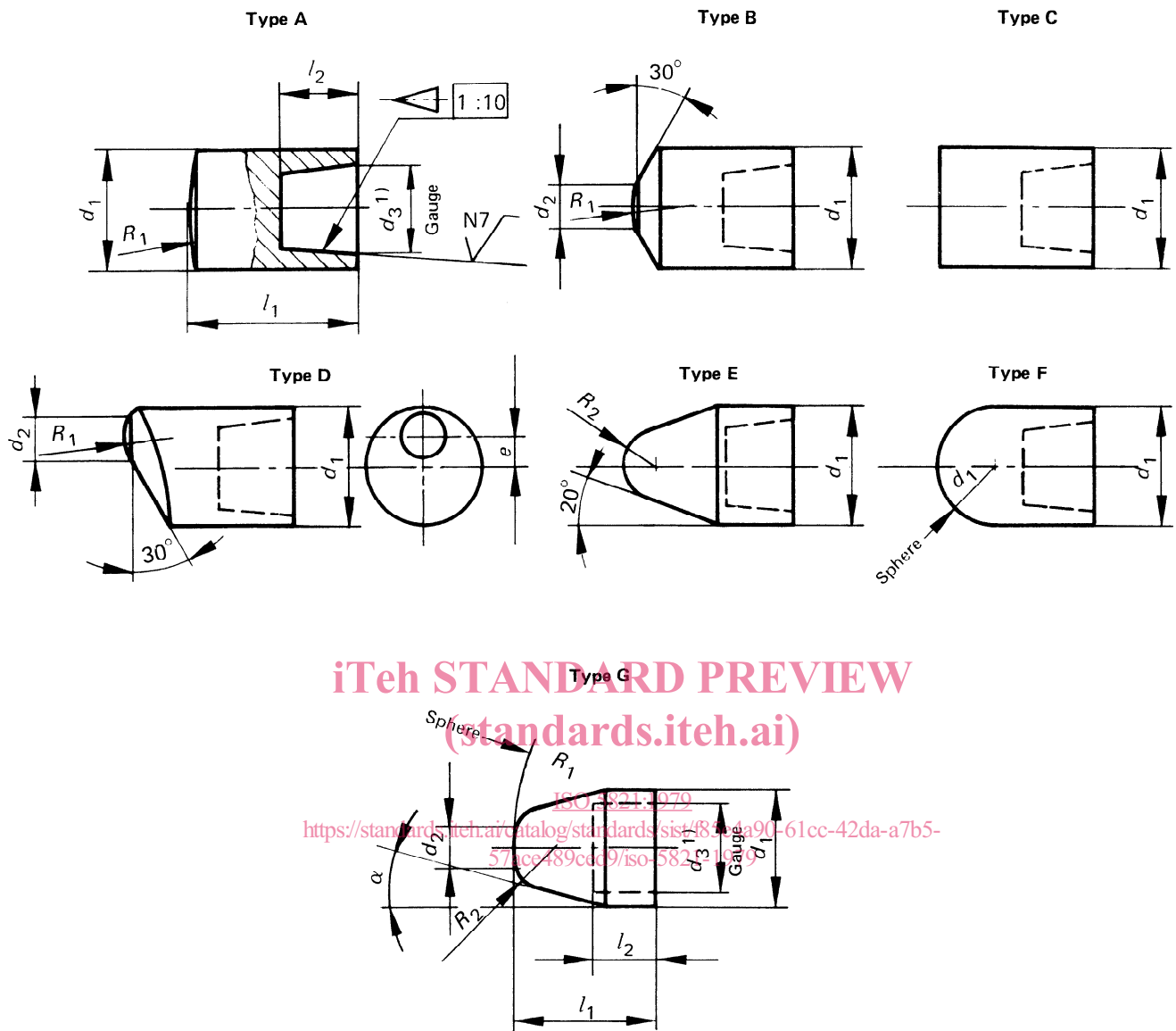

iTeh STANDARD PREVIEW  
(standards.iteh.ai)

<https://standards.iteh.ai/catalog/standards/sist/488490-61cc-42da-a7b5-57ace489cdd9/iso-5821-1979>

Table – Dimensions

Linear dimensions in millimetres

$d_1$ h11	$d_2$	$d_3^{(1)}$	$l_1$	$l_2 + {}^{0,5}_0$	$e$	$R_1$	$R_2$	$\alpha$	Electrode force <sup>2)</sup> $F_{max}$ kN
13	5	10	18	8	3	32	5	—	2,5
16	6	12	20	9,5	4	40	6	15°	4
20	8	15	22	11,5	5	50	8	22,5°	6,3

1)  $d_3$  is a gauge dimension at the datum line of the taper.

2) For information only.