International Standard



5827

INTERNATIONAL ORGANIZATION FOR STANDARDIZATION • МЕЖДУНАРОДНАЯ ОРГАНИЗАЦИЯ ПО СТАНДАРТИЗАЦИИ • ORGANISATION INTERNATIONALE DE NORMALISATION

Spot welding — Electrode back-ups and clamps

Machines à souder par points — Équipements inférieurs et brides de serrage

First edition — 1983-12-01

Corrected and reprinted — 1985-07-15

iteh STANDARD PREVIEW
(standards.iteh.ai)

[ISO 5827:1983](https://standards.iteh.ai/catalog/standards/sist/7b6bf2c4-5d8f-4c28-bc18-033a71aa96e7/iso-5827-1983)

<https://standards.iteh.ai/catalog/standards/sist/7b6bf2c4-5d8f-4c28-bc18-033a71aa96e7/iso-5827-1983>



UDC 621.791.763.1.037

Ref. No. ISO 5827-1983 (E)

Descriptors : welding, spot welding, welding electrodes, clamps, dimensions, specifications.

Foreword

ISO (the International Organization for Standardization) is a worldwide federation of national standards bodies (ISO member bodies). The work of preparing International Standards is normally carried out through ISO technical committees. Each member body interested in a subject for which a technical committee has been established has the right to be represented on that committee. International organizations, governmental and non-governmental, in liaison with ISO, also take part in the work.

Draft International Standards adopted by the technical committees are circulated to the member bodies for approval before their acceptance as International Standards by the ISO Council. They are approved in accordance with ISO procedures requiring at least 75 % approval by the member bodies voting.

International Standard ISO 5827 was prepared by Technical Committee ISO/TC 44, *Welding and allied processes*.

ITEH STANDARD PREVIEW
(standards.iteh.ai)

[ISO 5827:1983](https://standards.iteh.ai/catalog/standards/sist/7b6bf2c4-5d8f-4c28-bc18-033a71aa96e7/iso-5827-1983)

<https://standards.iteh.ai/catalog/standards/sist/7b6bf2c4-5d8f-4c28-bc18-033a71aa96e7/iso-5827-1983>

Spot welding – Electrode back-ups and clamps

1 Scope and field of application

This International Standard lays down the dimensions and specifies characteristics of spot welding electrode back-ups and clamps.

2 References

ISO 426/2, *Wrought copper-zinc alloys – Chemical composition and form of wrought products – Part 2 : Leaded copper-zinc alloys.*

ISO 1302, *Technical drawings – Method of indicating surface texture on drawings.*

ISO 5182, *Materials for resistance welding electrodes and ancillary equipment.*

3 Dimensions

3.1 Back-up profile (semi-finished product)

The dimensions of the back-up profile (semi-finished product) shall be as shown in figure 1.

3.1.1 Material

The material shall be A 1/1, as specified in ISO 5182.

3.1.2 Designation

The designation shall consist, in order, of the words “back-up profile”, the number of this International Standard, the form letter and the length of the back-up profile.

Example : a back-up profile form A and a length of 2 000 mm :

Back-up profile ISO 5827 A 2 000

ISO 5827:1983

<https://standards.iteh.ai/catalog/standards/sist/7b6bf2c4-5d8f-4c28-bc18-033a71aa96e7/iso-5827-1983>

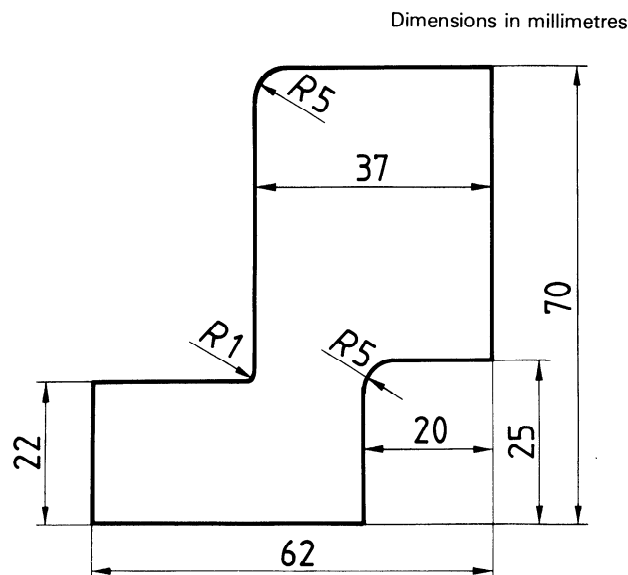

Figure 1 – Dimensions of the back-up profile – Form A

ISO 5827-1983 (E)

3.2 Wedge electrodes

The dimensions of the wedge electrode shall be as shown in figure 2 for form B, C or D.

3.2.1 Material

The material shall be A 2/2, as specified in ISO 5182.

3.2.2 Marking

Wedge electrodes to this International Standard shall be marked with the form letter and the material grade.

3.2.3 Designation

The designation shall consist, in order, of the words "wedge electrode", the number of this International Standard, the form letter and the electrode length.

Example : a wedge electrode form B and length equal to 50 mm would have the designation :

Wedge electrode ISO 5827 B 50

3.3 Clamps

The dimensions of the clamp shall be as shown in figure 3.

3.3.1 Material

The material shall be copper-zinc alloy (brass) Cu Zn40 Pb2 as specified in ISO 426/2, or similar.

3.3.2 Marking

Clamps to this International Standard shall be marked with the form letter and the width b_1 .

3.3.4 Designation

The designation shall consist, in order, of the word "clamp", the number of this International Standard, the form letter and the width of the clamp.

Example : a clamp form E and b_1 equal to 35 mm shall be designated as follows :

Clamp ISO 5827 E 35

Example : a clamp form F and b_1 equal to 20 mm shall be designated as follows :

Clamp ISO 5827 F 20

iTeh STANDARD PREVIEW
(standards.iteh.ai)

[ISO 5827:1983](https://standards.iteh.ai/catalog/standards/sist/7b6bf2c4-5d8f-4c28-bc18-033a71aa96e7/iso-5827-1983)

<https://standards.iteh.ai/catalog/standards/sist/7b6bf2c4-5d8f-4c28-bc18-033a71aa96e7/iso-5827-1983>

Dimensions in millimetres, surface roughness values in micrometres

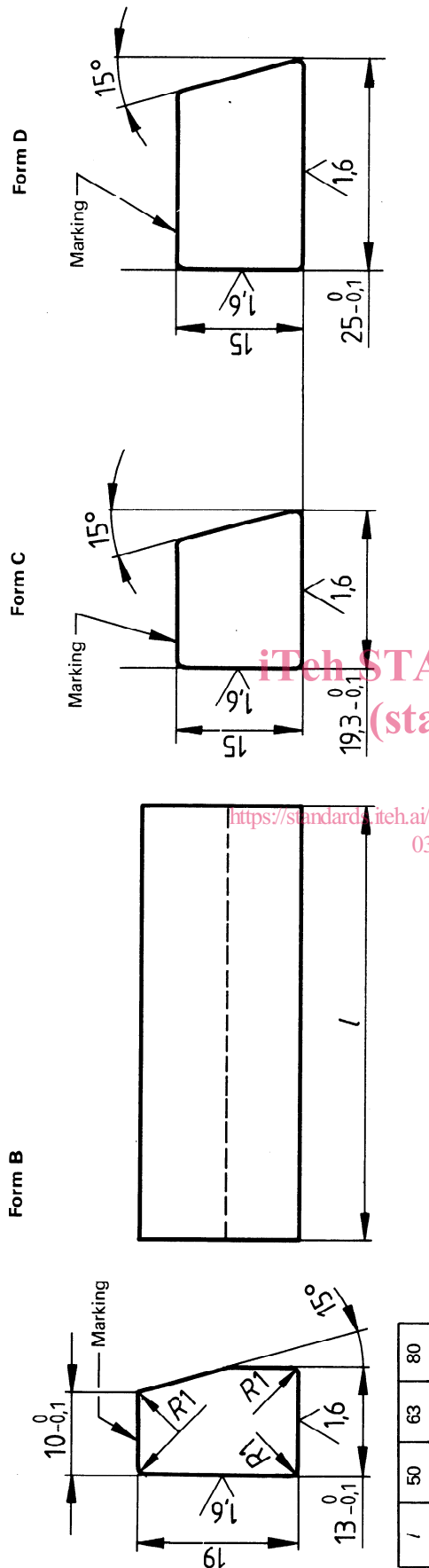

NOTE — For forms C and D, all other dimensions are as for form B.

Figure 2 — Dimensions of the wedge electrodes — Forms B, C and D

Dimensions in millimetres, surface roughness values in micrometres

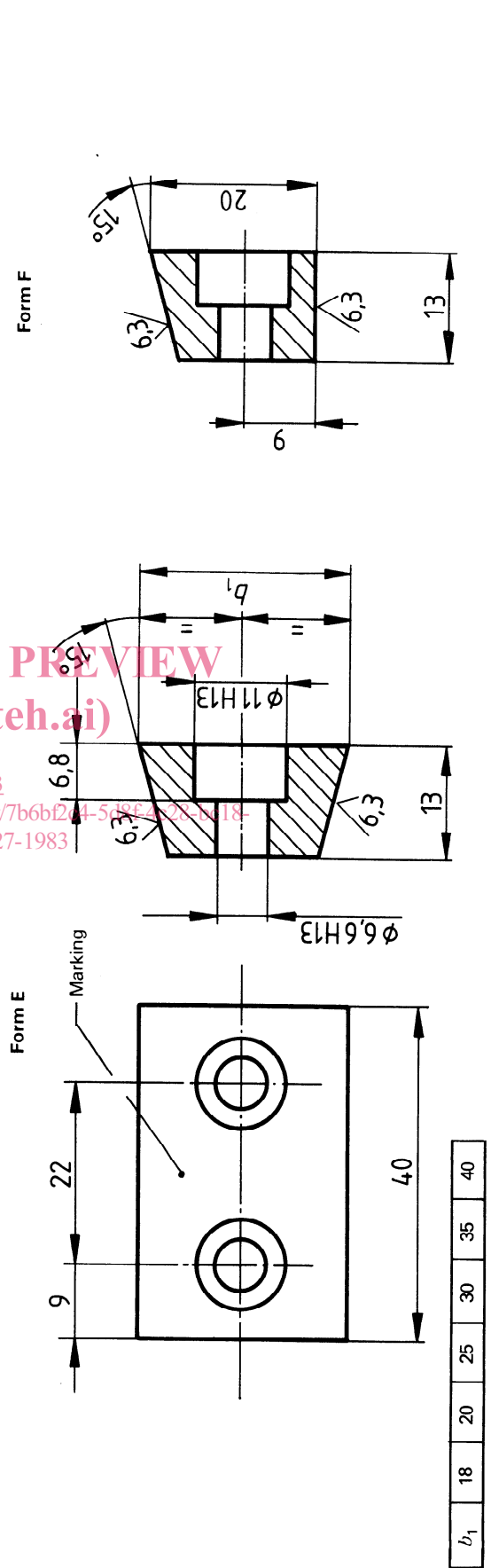

NOTE — For form F, all other dimensions are as for form E.

Figure 3 — Dimensions of clamps — Forms E and F

3.4 Back-ups with cooling holes (finished)

The dimensions of the back-up profile (finished) shall be as shown in figure 4 and given in the table.

Dimensions in millimetres, surface roughness values in micrometres

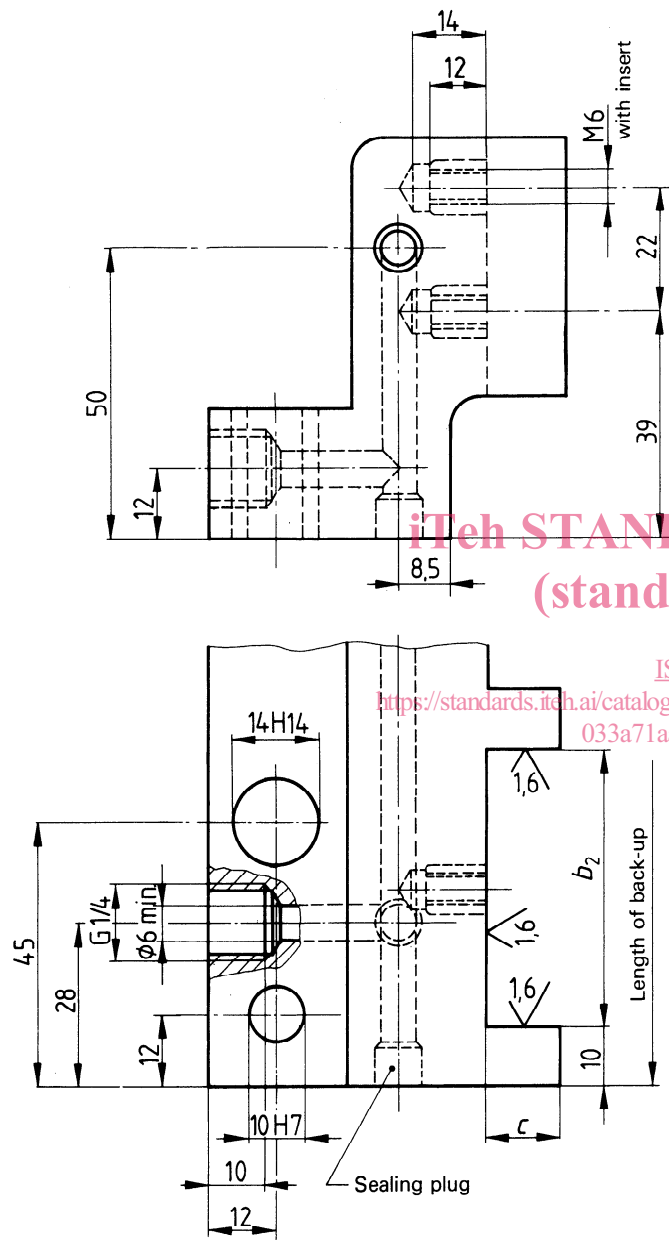

STANDARD PREVIEW
(standards.iteh.ai)

ISO 5827:1983

<https://standards.iteh.ai/catalog/standards/sist/7b6bf2c4-5d8f-4c28-bc18-033a71aa96e7/iso-5827-1983>

Table

Distance between spots a	b_2 $+0,2$ 0	c $+0,1$ 0	Wedge electrode	Clamp
25 ± 4	38	19	Form B	E 18
$31,5 \pm 4$	48	13	Form C	E 18
40 ± 4	55,5	13	Form C	E 25
45 ± 4	60,5	13	Form C	E 30
50 ± 4	65,5	13	Form C	E 35
56 ± 4	70,6	13	Form C	E 40
40 ± 10	62	13	Form D	E 20
50 ± 10	72	13	Form D	E 30
> 60 and single spots	35	13	Form C	F 20
	41		Form D	

Figure 4 – Dimensions of back-up with cooling holes

3.5 Layout of assembled back-ups

The layout of the assembled back-up shall be as given in figure 5.

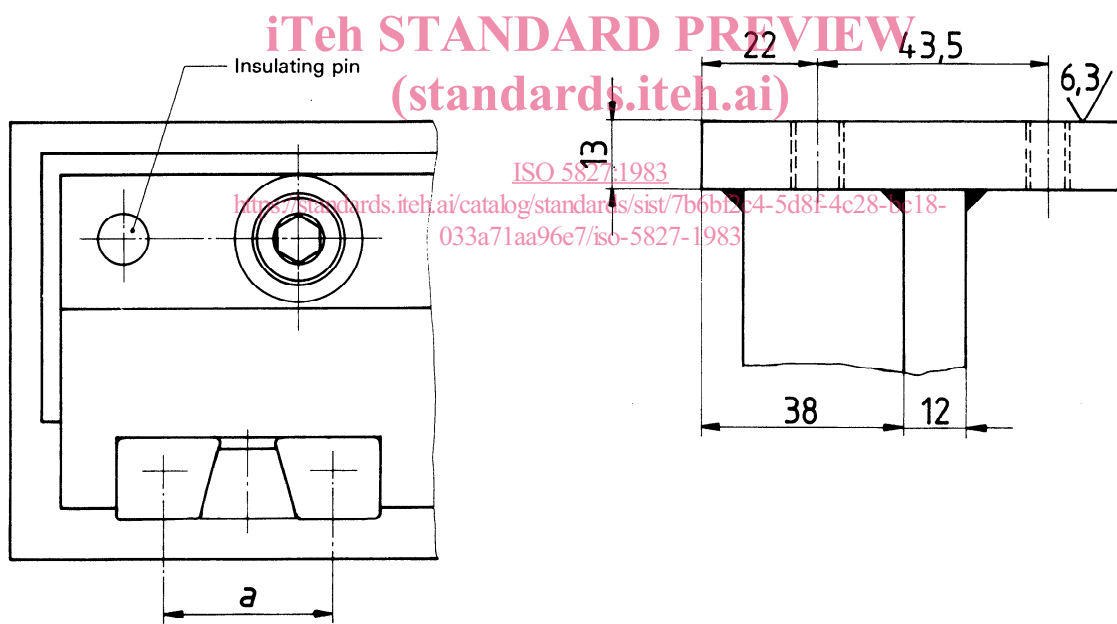
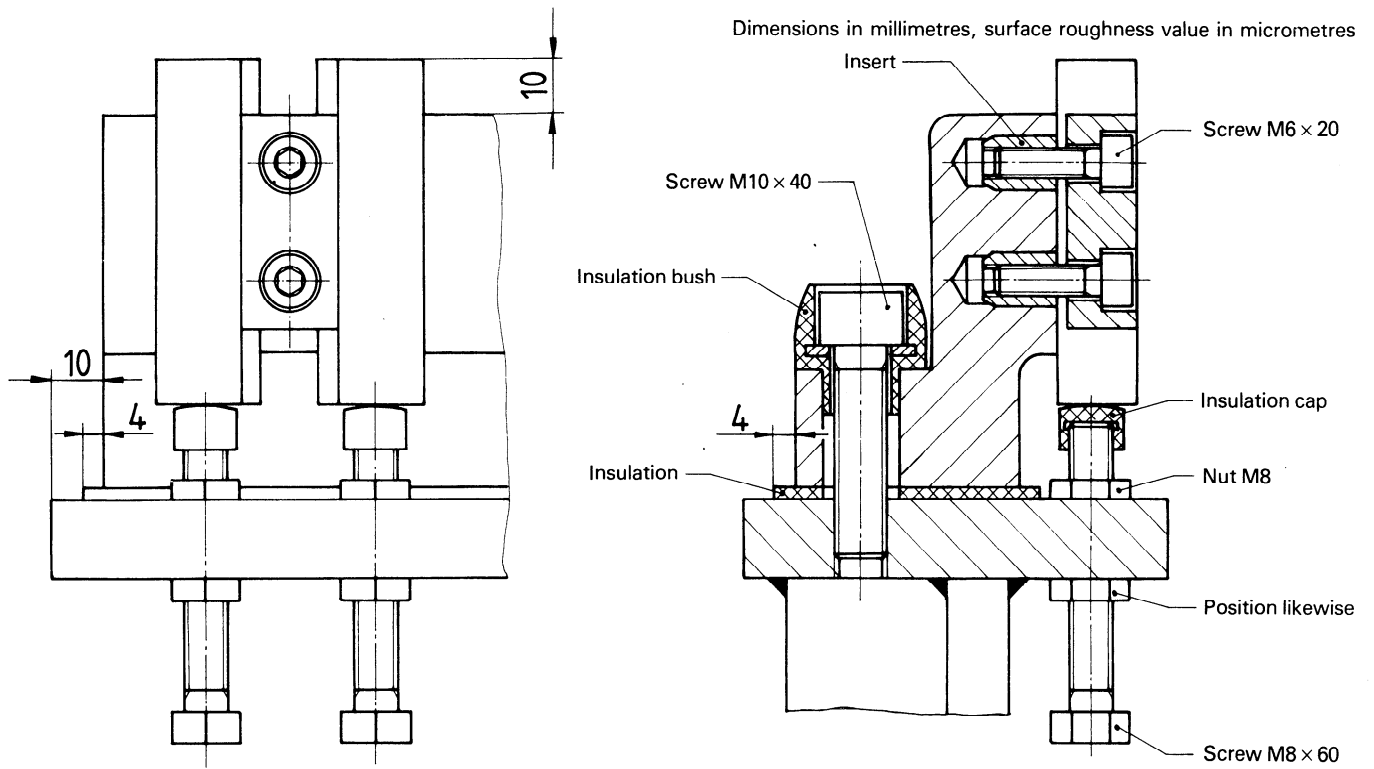

$a > 60$ mm and single spots

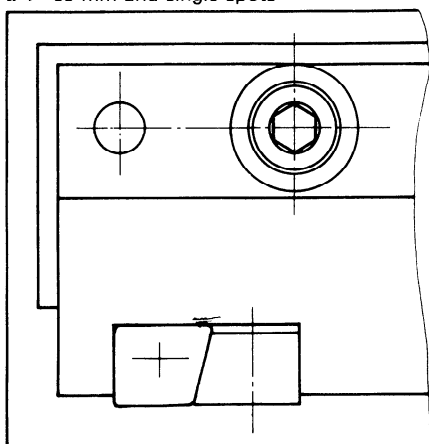

Figure 5 — Layout of the assembled back-up

4 Application

Complete back-ups can be simply represented, e.g. in weld studies, by the number of spots to be welded and the distance between spots, a , in accordance with the table in figure 4. A complete back-up for 8 spots with a distance between spots of 25 mm is shown in figure 6.

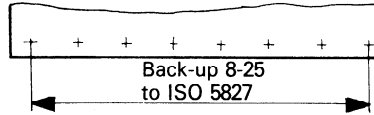

Figure 6 — Representation of a back-up 8-25

iTeh STANDARD PREVIEW
(standards.iteh.ai)

[ISO 5827:1983](https://standards.iteh.ai/catalog/standards/sist/7b6bf2c4-5d8f-4c28-bc18-033a71aa96e7/iso-5827-1983)

<https://standards.iteh.ai/catalog/standards/sist/7b6bf2c4-5d8f-4c28-bc18-033a71aa96e7/iso-5827-1983>