International Standard



5834/1

INTERNATIONAL ORGANIZATION FOR STANDARDIZATION • МЕЖДУНАРОДНАЯ ОРГАНИЗАЦИЯ ПО СТАНДАРТИЗАЦИИ • ORGANISATION INTERNATIONALE DE NORMALISATION

Implants for surgery — Ultra-high molecular weight polyethylene — Part 1 : Powder form

Implants chirurgicaux — Polyéthylène à très haute masse moléculaire — Partie 1 : Produits sous forme de poudre

First edition — 1985-07-01

iTeh STANDARD PREVIEW
(standards.iteh.ai)

ISO 5834-1:1985

<https://standards.iteh.ai/catalog/standards/sist/67247170-595b-4be5-9b9-29dcae1989a9/iso-5834-1-1985>

UDC 678.742.23-492 : 615.46

Ref. No. ISO 5834/1-1985 (E)

Descriptors : medical equipment, surgical implants, polyethylene, moulding materials, powdery materials, specifications, tests, labelling, test equipment.

Price based on 10 pages

Foreword

ISO (the International Organization for Standardization) is a worldwide federation of national standards bodies (ISO member bodies). The work of preparing International Standards is normally carried out through ISO technical committees. Each member body interested in a subject for which a technical committee has been established has the right to be represented on that committee. International organizations, governmental and non-governmental, in liaison with ISO, also take part in the work.

Draft International Standards adopted by the technical committees are circulated to the member bodies for approval before their acceptance as International Standards by the ISO Council. They are approved in accordance with ISO procedures requiring at least 75 % approval by the member bodies voting.

International Standard ISO 5834/1 was prepared by Technical Committee ISO/TC 150, *Implants for surgery*.

iTeh STANDARD PREVIEW
(standards.iteh.ai)

[ISO 5834-1:1985](https://standards.iteh.ai/catalog/standards/sist/67247170-595b-4be5-9bf9-29dcae1989a9/iso-5834-1-1985)

<https://standards.iteh.ai/catalog/standards/sist/67247170-595b-4be5-9bf9-29dcae1989a9/iso-5834-1-1985>

Implants for surgery — Ultra-high molecular weight polyethylene — Part 1 : Powder form

1 Scope and field of application

This part of ISO 5834 specifies the requirements and corresponding test methods for moulding material in powder form made from ultra-high molecular weight polyethylene (UHMWPE) for use in the manufacture of surgical implants.

It does not apply to finished products.

2 References

ISO 3856/5, *Paints and varnishes — Determination of "soluble" metal content — Part 5: Determination of hexavalent chromium content of the pigment and extender portion of the paint — Diphenylcarbazide spectrophotometric method.*

ISO 3451/1, *Plastics — Determination of ash — Part 1: General methods.*

ASTM D 1601, *Standard test method for dilute solution viscosity of ethylene polymers.*¹⁾

ASTM F 648, *Standard specification for ultra-high-molecular-weight polyethylene powder and fabricated form for surgical implants.*¹⁾

3 Definitions

For the purpose of this part of ISO 5834, the following definitions apply.

3.1 flow value (150/10) : The tensile stress in newtons per square millimetre necessary to elongate the length of the web of the specimen in a suitable medium (for example glycerin) at 150 °C by 600 % in 10 min when the test is in accordance with annex A. This flow value is designated "F (150/10)".

3.2 tensile stress (σ) : The quotient of the force²⁾ applied by the added weight, decreased by the buoyancy, and the original cross-sectional area of the web of the specimen.

NOTE — The very small mass of the lower clamp shoe is neglected.

4 Classification

The material shall be classified as Type A or Type B in accordance with the limits of contamination as given in 7.1.

5 Manufacturing requirements

The material shall consist of homopolymer prepared by the polymerization of pure ethylene using either the Ziegler process or the Philips process.

The powdered material supplied for each order shall be identified by batch or lot numbers.

NOTE — "Batch" or "lot" refers to the material for which testing has been carried out and for which discrete records are kept.

6 Flow properties

For both Type A and Type B material, either the flow value F (150/10) determined in accordance with 8.1 and annex A, shall be not less than 0,2 N/mm², or the relative solution viscosity determined in accordance with 8.2 and annex B shall be not less than 1,95.

NOTE — Compliance with either of the above test requirements indicates satisfactory polymer molecular weight.

1) These references will be replaced by references to appropriate International Standards when the latter become available.

2) Calculated by multiplying the mass by the acceleration of free fall equal to 9,81 m/s².

7 Limits of contamination

7.1 Ash and trace elements

The amount of ash, titanium, aluminium, calcium, chlorine, chromium and zirconium shall not exceed the respective maximum quantities specified in the table.

Table — Maximum ash and trace elements permitted in UHMWPE moulding powders for surgical implants

Contaminant	Maximum quantity permitted mg/kg (ppm)		Test method according to sub-clause
	Type A	Type B	
Ash	150	300	8.3
Titanium	20	150	8.4
Aluminium	40	50	8.4
Calcium	50	100	8.4
Chlorine	20	90	8.4
Chromium	<1	<1	8.4
Zirconium	<1	<1	8.4

7.2 Particulate matter

When the material is tested in accordance with 8.5, there shall be not more than 10 particles of contaminant found per 300 g of moulding material.

8 Methods of test

8.1 Flow value

The flow value F (150/10) shall be determined in accordance with annex A.

8.2 Relative solution viscosity

The relative solution viscosity shall be determined in accordance with annex B using a 0,05 % solution of the material in decalin at 135 °C.

8.3 Ash content

The ash content shall be determined in accordance with ISO 3451/1 performing duplicate tests on each of two test specimens.

8.4 Trace elements

The amount of chromium shall be determined in accordance with ISO 3856/5. The amounts of the other trace elements

listed in the table shall be determined in accordance with ASTM F 648.

8.5 Particulate matter

Mix four test portions of 75 g of the moulding material, each with 400 ml of propan-2-ol, in four 1 000 ml conical flasks. Shake each flask until the powder is thoroughly dispersed. Five minutes after cessation of shaking, examine the flasks with normal or corrected vision and count the number of particles that settle to the bottom of each flask.

9 Test certificate

The supplier shall furnish with each delivery a test certificate signed by a duly authorized representative of the supplier stating conformance with the requirements of this International Standard. In this certificate the results of the tests conducted shall be stated. The test certificate shall include the following information :

- purchase order number;
- the number of this International Standard (ISO 5834/1);
- batch or lot number;
- test values according to the appropriate clauses of this International Standard;
- statement of powder type, i.e. Type A or Type B;
- date(s) of test.

10 Labelling

Each package of moulding material shall be clearly marked with the following information :

- manufacturer's name or trademark;
- description of contents, i.e. UHMWPE moulding powder;
- batch or lot number;
- mass of the contents;
- purchase order number;
- the number of this International Standard (ISO 5834/1).

Annex A

Method for determining the flow value of UHMWPE moulding material

(This annex forms part of the standard.)

A.1 Scope and field of application

This annex specifies a method for determining the flow value of UHMWPE moulding material in powder form.

NOTE — The melt flow index cannot be determined for this material because of its ultra-high molecular weight.

A.2 Principle

Six test specimens are prepared from a compression moulded plate. The time taken to elongate the web of the test specimen 600 % at 150 °C is determined under various loads increasing from 110 to 300 gf from the first test to the sixth.

A.3 Test apparatus and material

A.3.1 3 000 ml glass beaker (1) of diameter approximately 150 mm and height approximately 200 mm.

A.3.2 Heating fluid (2) (glycerin is suitable) to fill the beaker (A.3.1).

A.3.3 Suitable external (2) (plate) **and internal** (3) (annular or immersion) **heaters**.

A.3.4 Contact thermometer (4).

A.3.5 Perforated plate (5) to fit near the bottom of the beaker (A.3.1).

A.3.6 Mercury-in-glass thermometer (6), graduated in intervals of 0,5 °C, suitable for measuring temperatures within the range 148 to 152 °C.

A.3.7 Stand (7) **and clamps** for supporting the specimen holder(s) (A.3.8).

A.3.8 Specimen holder (8) in accordance with figure 3 with arresting device (11).

A.3.9 Set of weights (10) of masses 110, 130, 160, 200, 250 and 300 g (m_1 , m_2 , m_3 , m_4 , m_5 and m_6 respectively) with hooks for suspension from the specimen holder (A.3.8) such that the height of the weights inclusive of hooks is uniform and equal to 41,5 mm.

A.3.10 Stopwatch, accurate to 0,1 s.

A.3.11 Measuring instruments, accurate to 0,02 mm, for measuring the widths and thicknesses of test specimens (9) in the web region.

A.4 Test sample

A representative sample sufficient for the tests to be carried out shall be taken from the moulding powder under test.

A.5 Preparation of test specimens

A.5.1 Introduction

Test specimens are punched from compression moulded plates prepared in accordance with A.5.2.

A.5.2 Compression moulding of the plates

A.5.2.1 Equipment and materials

A.5.2.1.1 Hydraulic laboratory press, capable of being heated and cooled to provide the moulding conditions specified in A.5.2.2.2.

A.5.2.1.2 Compression mould, of inside diameter approximately 140 mm.

A.5.2.1.3 Aluminium foil of thickness approximately 0,2 mm.

A.5.2.1.4 Stabilizing compound: 2-mercapto-benzimidazole [$C_6H_4NHC(SH)$], 1 mol/l solution.

A.5.2.2 Procedure

A.5.2.2.1 Thoroughly mix the test sample of moulding powder with 0,2 % (m/m) of the stabilizing compound.

NOTE — This addition should prevent cross-linking.

A.5.2.2.2 Line the compression mould (A.5.2.1.2) with the aluminium foil (A.5.2.1.3) and fill the mould with sufficient moulding powder to produce a moulded plate of thickness < 1,5 mm.

1) The encircled numbers of clause A.3 relate to the test arrangement shown diagrammatically in figure 2.

A.5.2.2.3 Using the laboratory press (A.5.2.1.1), prepare a plate by subjecting the filled mould to the following conditions :

- pressure (during heating and cooling) 10 N/mm²;
- temperature (during sintering) 200 °C;
- time of sintering 30 min;
- cooling time 10 to 20 min.

A.5.3 Punching out of the test specimens

From the moulded plate, punch out at least six test specimens conforming to the dimensions given in figure 1.

A.6 Procedure

A.6.1 Measurement of web cross-sections

The width and thickness of the web of each of six test specimens shall be measured and recorded to the nearest 0,02 mm.

A.6.2 Determination

A.6.2.1 Fill the beaker (A.3.1) with glycerin and raise the temperature to 150 ± 2 °C.

A.6.2.2 Clamp one of the test specimens in the holder (A.3.8) as shown in figure 3, hook the m_1 weight (see A.3.9) to the holder and suspend the specimen and weight in the heating fluid as shown in figure 2 with the holder arrested by the arresting device so that the specimen is not loaded by the weight; ensure that the base of the weight is 90 mm above the perforated plate (A.3.5).

A.6.2.3 Five minutes after the specimen has entered the heating fluid, free the holder from the arresting device and simultaneously start the stopwatch (A.3.10).

A.6.2.4 At the moment that the descending weight touches the perforated plate (A.3.5), stop the watch and record the time taken for the 600 % elongation of the web of the specimen.

A.6.2.5 Repeat the determination described in A.6.2.1 to A.6.2.4 inclusive using in turn each of the m_2, m_3, m_4, m_5 and m_6 weights.

NOTE — Elongation of the test specimens does not take place at constant speed. This phenomenon is shown diagrammatically in figure 4.

The curve shows that elongation is accelerated as the 600 % elongation point is approached.

A.6.3 Number of tests

Six tests are performed on six test specimens provided from the one plate.

A.7 Expression of results

For each six separate determinations, the tensile stress σ_i , expressed in newtons per square millimetre, is given by the equation

$$\sigma_i = \frac{m_i \times 9,81}{b_i \times S_i}$$

where

m_i corresponds to mass m_1, m_2, \dots, m_6 , in grams;

b_i corresponds to width b_1, b_2, \dots, b_6 , in millimetres, of the web of the specimen;

S_i corresponds to thickness S_1, S_2, \dots, S_6 , in millimetres, of the web of the specimen.

Using a log/log scale plot the tensile stresses for the six specimens against their corresponding times of 600 % elongation recorded in A.6.2.4 and A.6.2.5.

NOTE The six points plotted should lie on a straight line. An undue amount of scatter will indicate that partial cross-linking has occurred in the test specimens. In such a case further specimens will need to be prepared using an increased amount of stabilizer (see A.5.2.2.1), and the whole procedure repeated.

Draw a line through the points and from this graph read off the tensile stress corresponding to an elongation period of 10 min [F (150/10)].

A.8 Test report

The test report shall include the following information :

- a) identification of the UHMWPE moulding powder tested including reference to type;
- b) flow value F (150/10) in newtons per square millimetre;
- c) details of any departures from the standard method specified herein;
- d) date of test.

Dimensions in millimetres

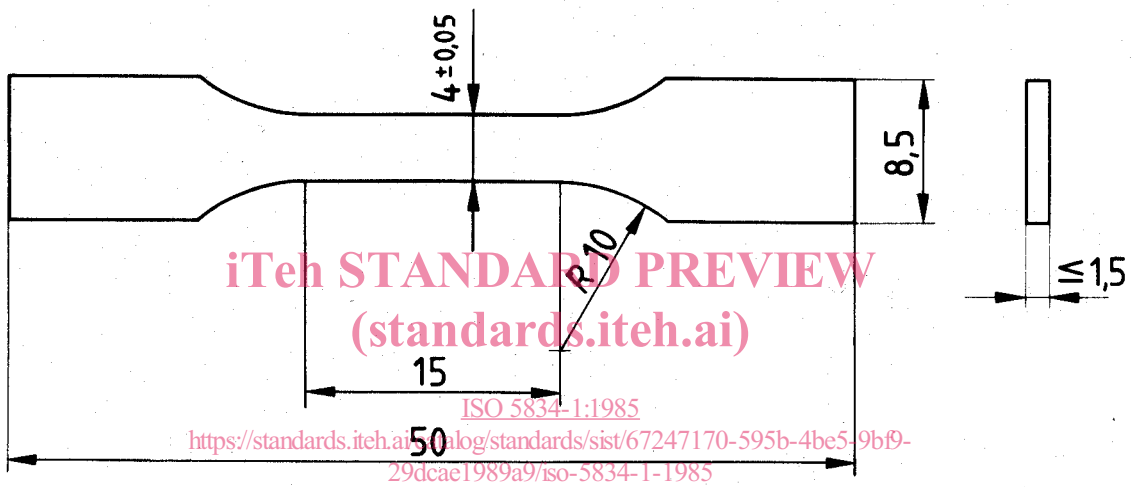

Figure 1 – Specimen

Dimension in millimetres

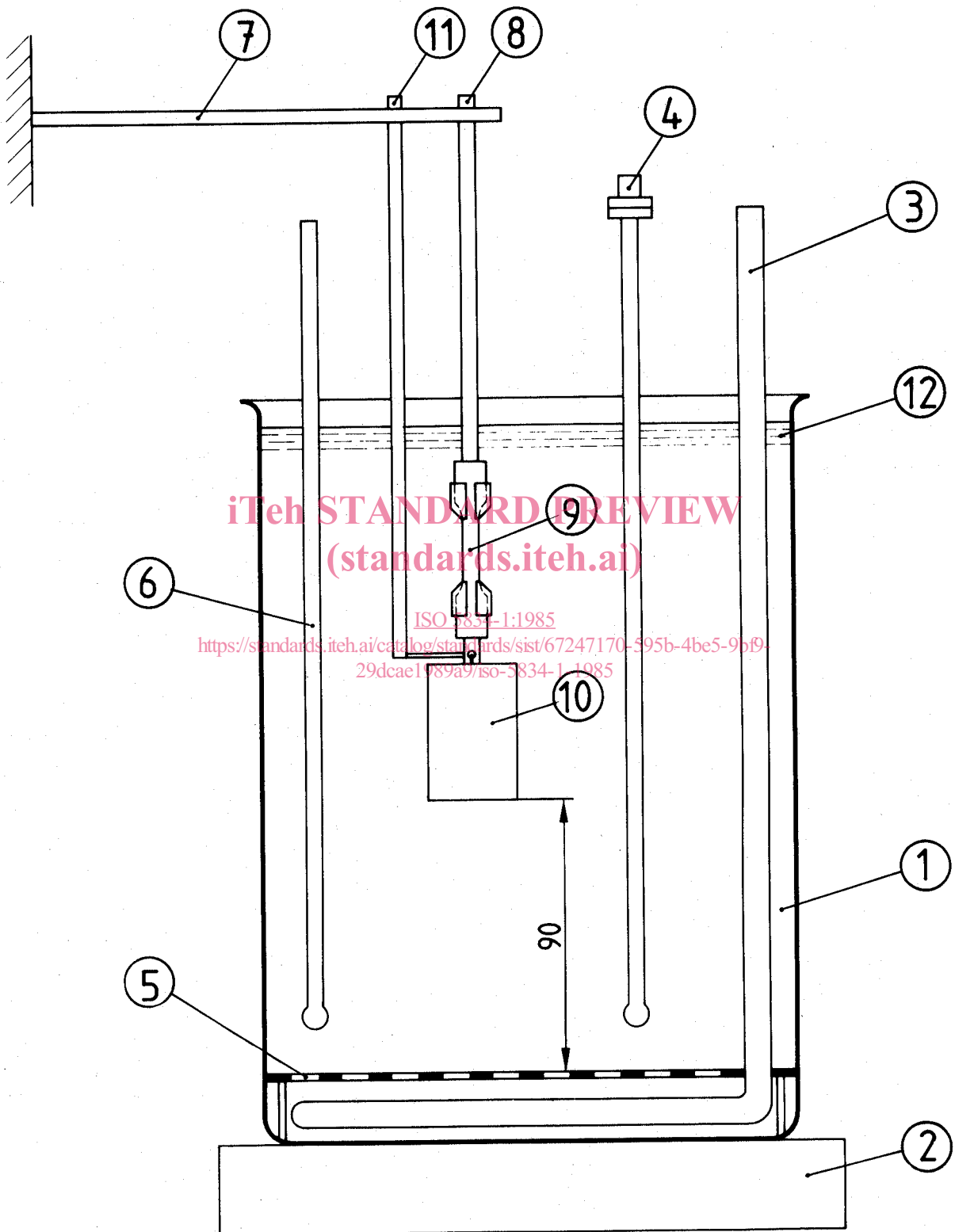

Figure 2 — Schematic diagram of the apparatus for determining the flow value

Dimensions in millimetres

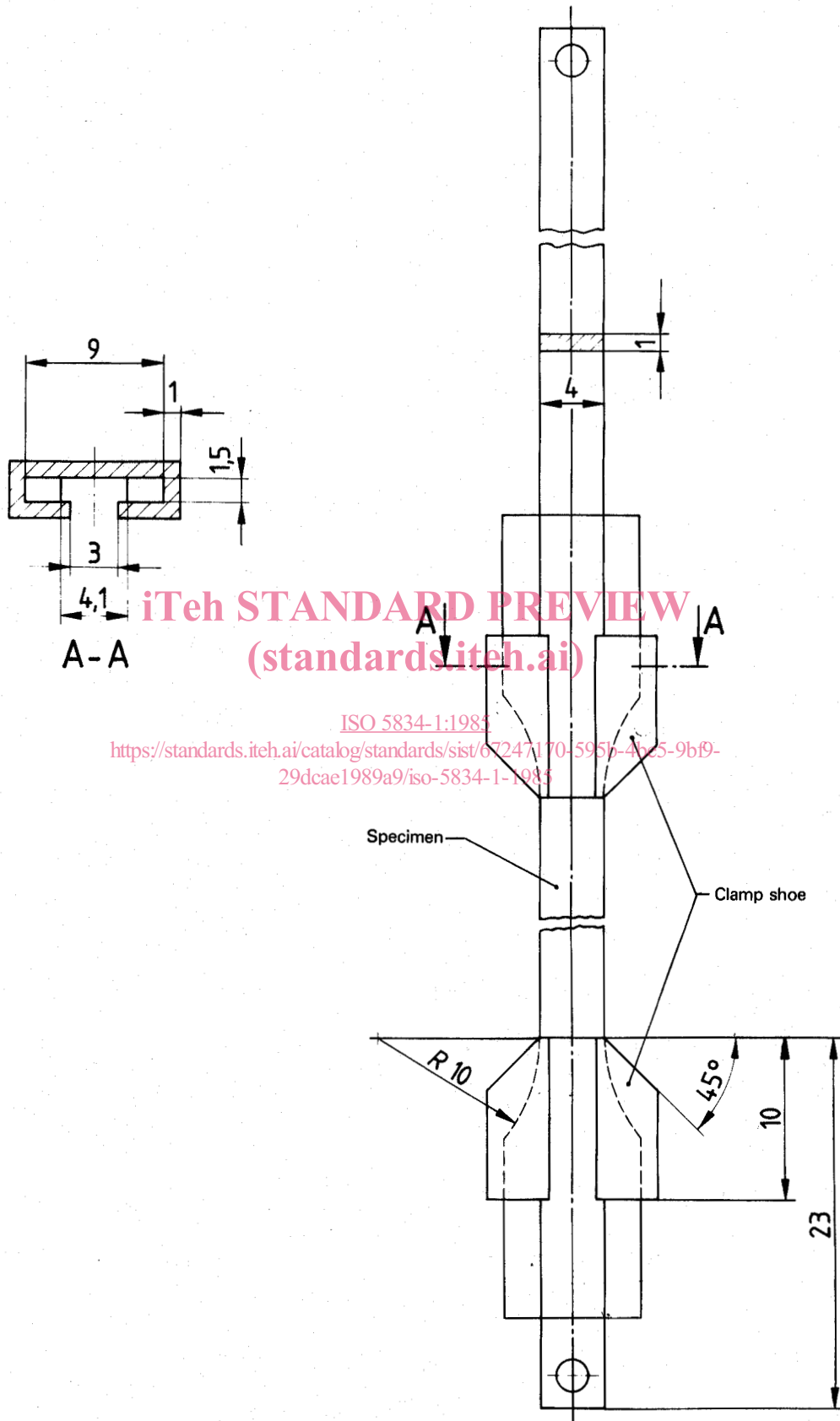

Figure 3 — Specimen holder