

INTERNATIONAL
STANDARD

ISO
10787-2

First edition
1994-12-15

**Textile machinery and accessories —
Heald frames —**

Part 2:

**Heald-carrying rod fixed directly on the frame
stave — Coordinated dimensions**

<https://standards.iteh.ai/catalog/standards/sist/5524e169-c873-51d-3dd194f1ac4b/iso-10787-2-1994>

Matériel pour l'industrie textile — Cadres de lisses —

*Partie 2: Tringles porte-lisses fixées directement aux liteaux —
Dimensions interdépendantes*



Reference number
ISO 10787-2:1994(E)

Foreword

ISO (the International Organization for Standardization) is a worldwide federation of national standards bodies (ISO member bodies). The work of preparing International Standards is normally carried out through ISO technical committees. Each member body interested in a subject for which a technical committee has been established has the right to be represented on that committee. International organizations, governmental and non-governmental, in liaison with ISO, also take part in the work. ISO collaborates closely with the International Electrotechnical Commission (IEC) on all matters of electrotechnical standardization.

Draft International Standards adopted by the technical committees are circulated to the member bodies for voting. Publication as an International Standard requires approval by at least 75 % of the member bodies casting a vote.

International Standard ISO 10787-2 was prepared by Technical Committee ISO/TC 72, *Textile machinery and allied machinery and accessories*, Subcommittee SC 3, *Machinery for fabric manufacture*.

The first edition of ISO 10787-2 cancels and partially replaces ISO 568:1976 and ISO 569:1982, which have been technically revised and expanded.

ISO 10787 consists of the following parts, under the general title *Textile machinery and accessories — Heald frames*:

- Part 1: *Heald-carrying rod fixed to the frame stave by rod support — Coordinated dimensions*
- Part 2: *Heald-carrying rod fixed directly on the frame stave — Coordinated dimensions*
- Part 3: *Guides for heald frames*

Annex A of this part of ISO 10787 is for information only.

© ISO 1994

All rights reserved. Unless otherwise specified, no part of this publication may be reproduced or utilized in any form or by any means, electronic or mechanical, including photocopying and microfilm, without permission in writing from the publisher.

International Organization for Standardization
Case Postale 56 • CH-1211 Genève 20 • Switzerland

Printed in Switzerland

Textile machinery and accessories — Heald frames —

Part 2:

Heald-carrying rod fixed directly on the frame stave — Coordinated dimensions

iTeh STANDARD PREVIEW (standards.iteh.ai)

[ISO 10787-2:1994](https://standards.iteh.ai/catalog/standards/sist/e55564ac-16c9-4372-b5e4-3dd194fdac4b/iso-10787-2-1994)

<https://standards.iteh.ai/catalog/standards/sist/e55564ac-16c9-4372-b5e4-3dd194fdac4b/iso-10787-2-1994>

1 Scope

This part of ISO 10787 specifies the coordinated dimensions of heald frames on which the heald-carrying rod is fixed directly on the frame stave.

2 Normative reference

The following standard contains provisions which, through reference in this text, constitute provisions of this part of ISO 10787. At the time of publication, the edition indicated was valid. All standards are subject to revision, and parties to agreements based on this part of ISO 10787 are encouraged to investigate the possibility of applying the most recent edition of the standard indicated below. Members of IEC and ISO maintain registers of currently valid International Standards.

ISO 2768-1:1989, *General tolerances — Part 1: Tolerances for linear and angular dimensions without individual tolerance indications*.

3 Heald frame

Figures 1 and 2 and table 1 define and specify the dimensions of heald frames on which the heald-carrying rod is fixed directly on the frame stave.

4 Heald frame connections

Figures 3 and 4 show heald frame connections at the upper and lower frame staves, respectively, while table 2 specifies their dimensions.

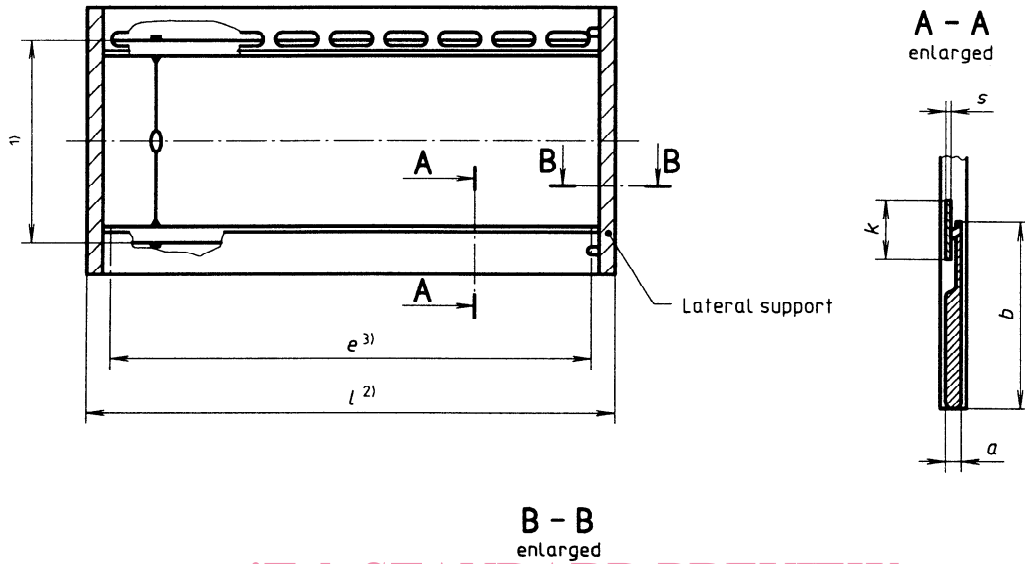

Group guidance of heald frames

Single guidance of heald frames

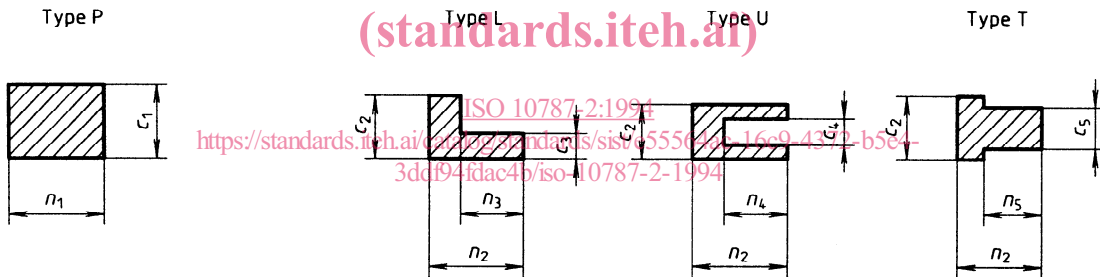

- 1) The distance between heald-carrying rods depends on the distance l between end loops of healds.
- 2) The width l of the heald frame depends on the construction of the weaving machine and should therefore be agreed upon between machine manufacturer and purchaser.
- 3) The working width e of the heald frame is equal to the working length of the heald-carrying rods on which the healds are strung.

Figure 1 — Heald frame

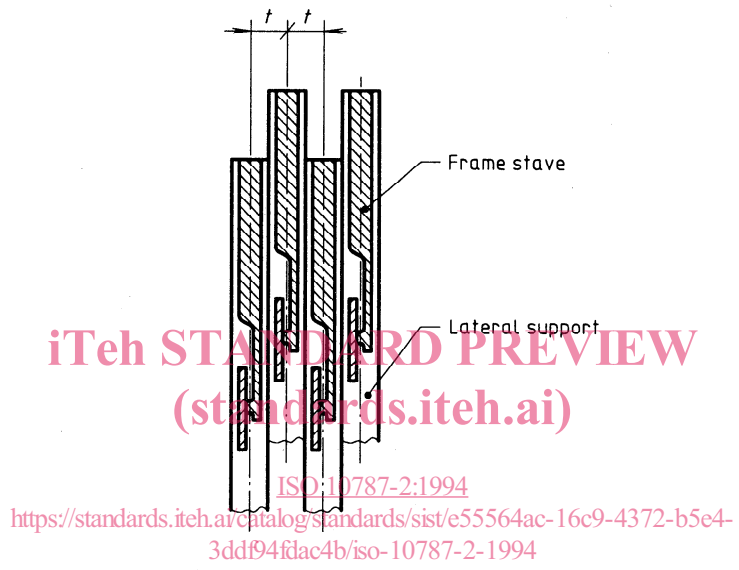

Figure 2 — Pitch t of the harness

Table 1 — Heald frame dimensions

Dimensions in millimetres

Pitch of harness <i>l</i> ¹⁾ nom.	Thickness of frame stave <i>a</i> nom.	Height of frame stave <i>b</i> nom.	Heald frame lateral support																									
			For group guidance of heald frames		For single guidance of heald frames																							
			Type P		Type L				Type U				Type T															
			<i>c</i> ₁	<i>n</i> ₁	<i>c</i> ₂	<i>c</i> ₃	<i>n</i> ₂	<i>n</i> ₃	<i>c</i> ₂	<i>c</i> ₄	<i>n</i> ₂	<i>n</i> ₄	<i>c</i> ₂	<i>c</i> ₅	<i>n</i> ₂	<i>n</i> ₅												
			0 -0,2		0 -0,2	0 -0,2					0 -0,2	+0,2 0			0 -0,2	0 -0,2												
12	9	84 96 120	11,8	16 18 20 24 30	11,8	4,8	16	11	10,2	5 6,7	15	12	10	4,8 7,8	16	10	11											
(14)	9 11																											
18	9 11 12		17,8				16	11			15	12																
							18	12			18	12																
							16	11			16	11																
							18	12			18	12																
24	16 18		23,8		—	—	—	—	—	—	—	—	—	—	—	—	—											

1) Pitch *l* of the harness: distance between the midpoints of two adjacent heald frames of a harness in a weaving machine. Normally the pitch of the harness is equal to the pitch of the shedding motion, i.e. the distance between the midpoints of the needles in the dobby or other driving mechanism of the heald frames. The dimension shown in parentheses should be avoided for new constructions.

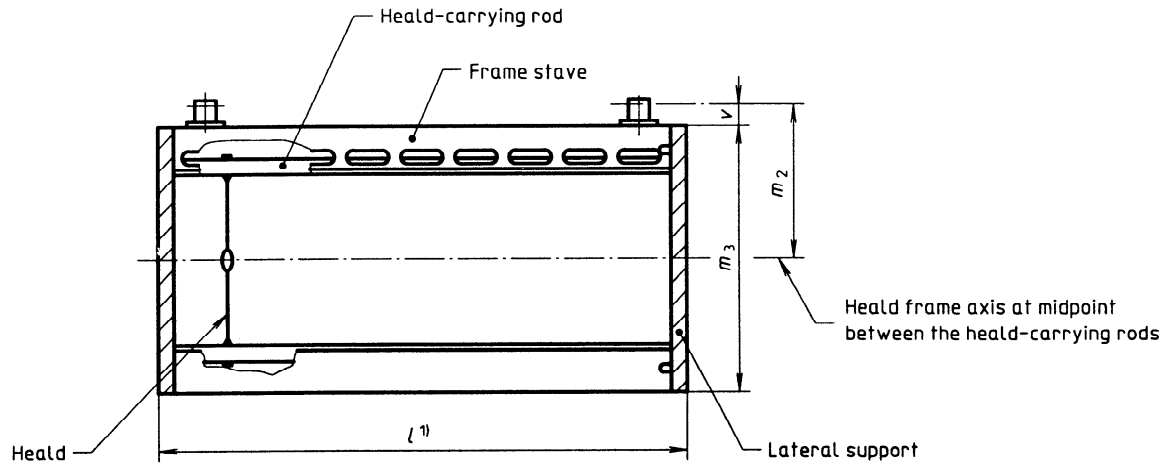

1) See figure 1.

Figure 3 — Heald frame connection at the upper frame stave

iTeh STANDARD PREVIEW
(standards.iteh.ai)

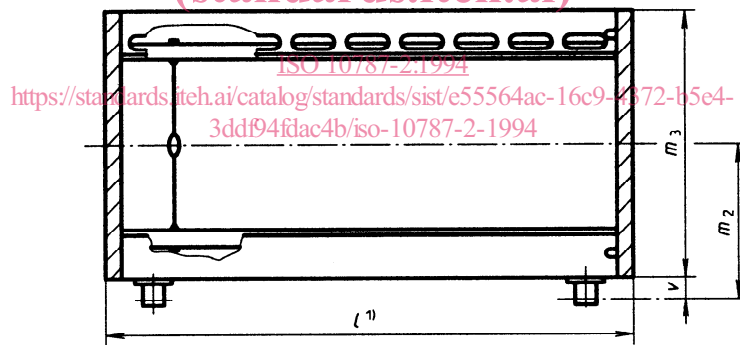

1) See figure 1.

Figure 4 — Heald frame connection at the lower frame stave

Table 2 — Heald frames, riderless, with heald-carrying rod fixed directly on the frame stave

Dimensions in millimetres

Cross-section of heald-carrying rod		b nom.	Heald frame connections for upper and lower frame staves								
k ¹⁾	s ¹⁾		m ₂ ± 0,5	m ₃ ± 1	m ₂ ± 0,5	m ₃ ± 1	m ₂ ± 0,5	m ₃ ± 1	m ₂ ± 0,5	m ₃ ± 1	
Nominal distance L between end loops of healds ²⁾											
		280		331		382		407			
22	1,7	84	3)	410	3)	461	3)	512	3)	563	3)
		96		434		485		536		587	
		120		482		533		584		635	
16	2,1	84	3)	407	3)	458	3)	509	3)	560	3)
		96		431		482		533		584	
		120		479		530		581		632	

1) Tolerances are given in ISO 2768-1, tolerance class fine. Heald-carrying rod 22 mm × 1,7 mm suitable for healds with C-shaped end loops; heald-carrying rod 16 mm × 2,1 mm suitable for healds with J-shaped end loops.

2) The distances between end loops of healds are derived from inch dimensions.

3) $m_2 = \frac{m_3}{2} + v$

The value of v depends on the kind of heald frame connection and is therefore fixed by the machine manufacturer.

ISO 10787-2:1994
<https://standards.iteh.ai/catalog/standards/sist/e55564ac-16c9-4372-b5e4-3dd194fdac4b/iso-10787-2-1994>

Annex A (informative)

Bibliography

- [1] ISO 286-2:1988, *ISO system of limits and fits — Part 2: Tables of standard tolerance grades and limit deviations for holes and shafts.*
- [2] ISO 11677-1:1994, *Textile machinery and accessories — Main dimensions of flat steel healds with open end loops — Part 1: C-shaped end loops.*
- [3] ISO 11677-2:1994, *Textile machinery and accessories — Main dimensions of flat steel healds with open end loops — Part 2: J-shaped end loops.*

iTeh STANDARD PREVIEW
(standards.iteh.ai)

[ISO 10787-2:1994](https://standards.iteh.ai/catalog/standards/sist/e55564ac-16c9-4372-b5e4-3dd194fdac4b/iso-10787-2-1994)

<https://standards.iteh.ai/catalog/standards/sist/e55564ac-16c9-4372-b5e4-3dd194fdac4b/iso-10787-2-1994>