

INTERNATIONAL ELECTROTECHNICAL COMMISSION
COMMISSION ÉLECTROTECHNIQUE INTERNATIONALE

IEC 61851-1
Edition 3.0 2017-02

IEC 61851-1
Édition 3.0 2017-02

**ELECTRIC VEHICLE CONDUCTIVE CHARGING
SYSTEM –**

**SYSTÈME DE CHARGE CONDUCTIVE POUR
VÉHICULES ÉLECTRIQUES –**

Part 1: General requirements

Partie 1: Exigences générales

CORRIGENDUM 1

Corrections to the French version appear after the English text.

Les corrections à la version française sont données après le texte anglais.

<https://standards.iteh.ai>
Document Preview

4 General requirements

Replace the eighth paragraph with the following: [7/COR1:2023](https://standards.iteh.ai/catalog/standards/sist/32df74b8-2bea-4193-b904-ab88b9e01ed6/iec-61851-1-2017-cor1-2023)

Assemblies for EV supply equipment shall comply with IEC TS 61439-7 with the exceptions or additions as indicated in Clause 12.

12.9 Damp heat functional test

Replace the second paragraph with the following:

Conditioning:

- for indoor units, 6 cycles of 24 h each to a damp heat cycling test according to IEC 60068-2-30 (Test Db) at (40 ± 3) °C and relative humidity of 95 %;
- for outdoor units, two 5-day periods, with each period consisting of 5 cycles of 24 h each to a damp heat cycling test according to IEC 60068-2-30 (Test Db) at (40 ± 3) °C and relative humidity of 95 %.

12.11 Mechanical strength

Replace, in the second paragraph, the first dashed item with the following:

- the IP degree according to 12.4 is not impaired;

Table A.6 – List of sequences

Replace, in sequence 2.1 Unplug at state Bx, in the “Conditions” column, the text for (19) and (20) with the following:

(19) EV connected to the EV supply equipment in state B

(20) Plug disconnected from the EV supply equipment or vehicle connector disconnected from the vehicle inlet

The EV supply equipment shall allow removal of the plug automatically, at a maximum of 5 s, when entering state A (case A or B) unless the locking was initiated through user interaction (e.g. authorization). Then unlatching / unlocking can be done only by using the adequate user interaction or both.

In case A, EV with attached cable, a switch may be added on the control pilot circuit, on the EV side (cable, plug, vehicle), to simulate the EV disconnection (state A).

A.4.9 Test of short-circuit values of the voltage

Replace the second paragraph with the following:

The test shall be initiated with $R_{2\text{test}}$ and $R_{3\text{test}}$ at the nominal value. When state C or D has been attained for at least 5 s, a supplementary resistance of 80 Ω is switched to connect between the control pilot conductor and the protective conductor.

Figure A.8 – Example of a test circuit (EV simulator)

In the figure, replace the resistor values for R13, R31 and R32 as follows:

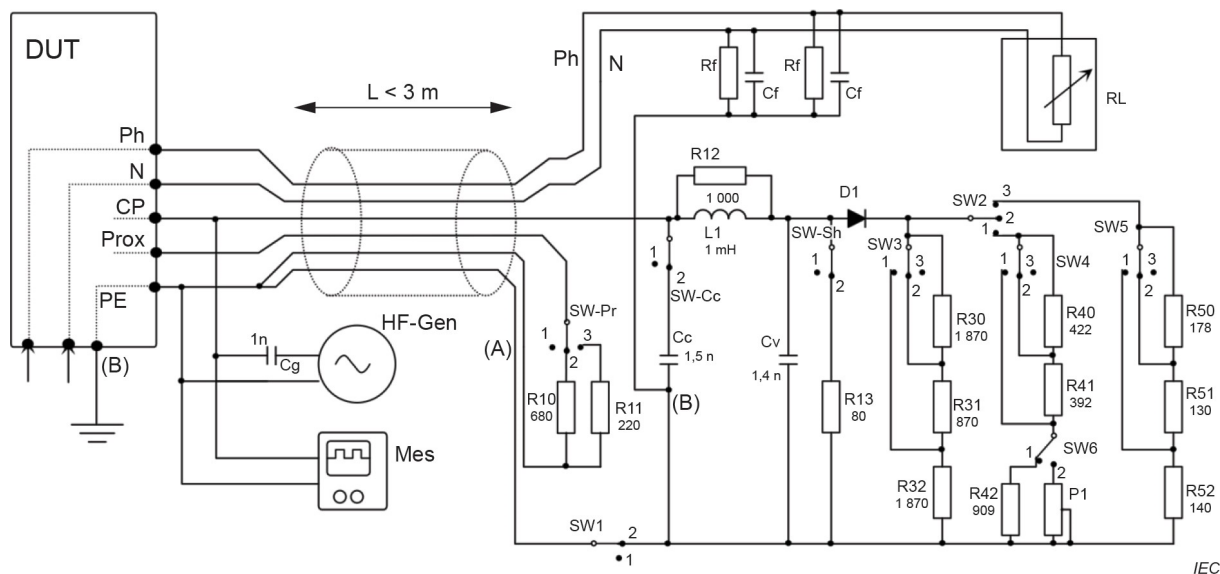

Replace, in NOTE 2, the description of resistance R3 with the following:

The resistance R3 in Figure A.1 is simulated by SW3 and resistors R30 (1 870 Ω), R31 (870 Ω) and R32 (1 870 Ω) as follows:

- Position 2: $R_{3\text{test}}$ has its nominal value;

© IEC 2023

- Position 1: $R3_{\text{test}}$ has the minimum test value;
- Position 3: $R3_{\text{test}}$ has the maximum test value.

C.2 Circuits diagrams for Mode 1, Mode 2 and Mode 3, using a basic single phase vehicle coupler

Delete Figure C.3.

Replace the first paragraph with the following:

Figures C.1, C.2 and C.4 below show the application of a single phase basic interface fitted with a switch on the proximity circuits.

Replace the fourth paragraph with the following:

Figures C.1, C.2 and C.4 can also be realized with a connector that lacks a switch provided the switch S3 is not required.

Replace the ninth paragraph with the following:

Both Mode 2 diagram shown in Figure C.2 and Mode 3 diagram shown in Figure C.4 have been drawn with a hard wired control pilot functions as described in Annex A. The basic functions described in Annex A are represented by R1, R2, R3, D and S2 (see Figure A.1). The values indicated in Annex A should be used (see Table A.3).

D.10.6 Test of short circuit between the control pilot conductor and the protective conductor

Replace the third paragraph with the following:

A supplementary resistance of 80 Ω is switched to connect the control pilot conductor and the protective conductor.