

# INTERNATIONAL STANDARD

**ISO**  
**2328**

Second edition  
1993-11-01

---

---

## Fork-lift trucks — Hook-on type fork arms and fork arm carriages — Mounting dimensions

iTeh STANDARD PREVIEW

*(standards.iteh.ai)* Chariots élévateurs à fourche — Bras de fourche à tenons et tabliers  
porte-équipements — Dimensions de montage

ISO 2328:1993

<https://standards.iteh.ai/catalog/standards/sist/3b9c1721-0faa-4cfe-81b4-d9778950f55c/iso-2328-1993>



Reference number  
ISO 2328:1993(E)

## Foreword

ISO (the International Organization for Standardization) is a worldwide federation of national standards bodies (ISO member bodies). The work of preparing International Standards is normally carried out through ISO technical committees. Each member body interested in a subject for which a technical committee has been established has the right to be represented on that committee. International organizations, governmental and non-governmental, in liaison with ISO, also take part in the work. ISO collaborates closely with the International Electrotechnical Commission (IEC) on all matters of electrotechnical standardization.

Draft International Standards adopted by the technical committees are circulated to the member bodies for voting. Publication as an International Standard requires approval by at least 75 % of the member bodies casting a vote.

International Standard ISO 2328 was prepared by Technical Committee ISO/TC 110, *Industrial trucks*, Sub-Committee SC 2, *Safety of powered industrial trucks*.

<https://standards.iteh.ai/catalog/standards/sist/3b9c1721-0faa-4cfe-81b4-c977895025c/iso-2328-1993>

This second edition cancels and replaces the first edition (ISO 2328:1977). Class 4 in tables 1 and 2 has been extended; class 5 is new, as is clause 5.

© ISO 1993

All rights reserved. No part of this publication may be reproduced or utilized in any form or by any means, electronic or mechanical, including photocopying and microfilm, without permission in writing from the publisher.

International Organization for Standardization  
Case Postale 56 • CH-1211 Genève 20 • Switzerland

Printed in Switzerland

# Fork-lift trucks — Hook-on type fork arms and fork arm carriages — Mounting dimensions

## 1 Scope

This International Standard specifies the dimensions and some additional requirements of fork carriers and hook-on type fork arms for fork-lift trucks, to permit interchangeability of fork arms and/or other attachments, related to the truck rated capacity and type of fork arm.

## 2 Normative reference

The following standard contains provisions which, through reference in this text, constitute provisions of this International Standard. At the time of publication, the edition indicated was valid. All standards are subject to revision, and parties to agreements based on this International Standard are encouraged to investigate the possibility of applying the most recent edition of the standard indicated below. Members of IEC and ISO maintain registers of currently valid International Standards.

ISO 2331:1974, *Fork lift trucks — Hook-on type fork arms — Vocabulary*.

## 3 Definitions

For the purposes of this International Standard, the definitions given in ISO 2331 apply.

## 4 Dimensions

The mounting dimensions of fork arms and fork carriers for types A and B fork arms shall be in accordance with the appropriate dimensions given in figure 1, and tables 1 and 2 respectively.

Fork arm location slots to the dimensions specified in table 2 shall be provided at suitable spacings on the fork arm carrier. One slot shall be situated on the carrier plate centreline in order to locate attachments.

NOTE 1 Tables 1 and 2 specify dimensions for two types of fork arm, designated A and B, for each value of truck rated capacity.

## 5 Additional requirements

**5.1** Stops shall be provided in order to prevent lateral disengagement of the fork arms from the extremities of the fork carrier.

**5.2** If a fork arm removal slot is provided at the bottom of the fork carrier, it shall not be positioned opposite a location slot at the top of the carrier unless means are provided to prevent the fork arm being inadvertently displaced.

NOTE 2 ISO 2330:1974, *Fork lift trucks — Fork arms — Technical characteristics and testing* specifies the technical characteristics and test requirements of fork arms.

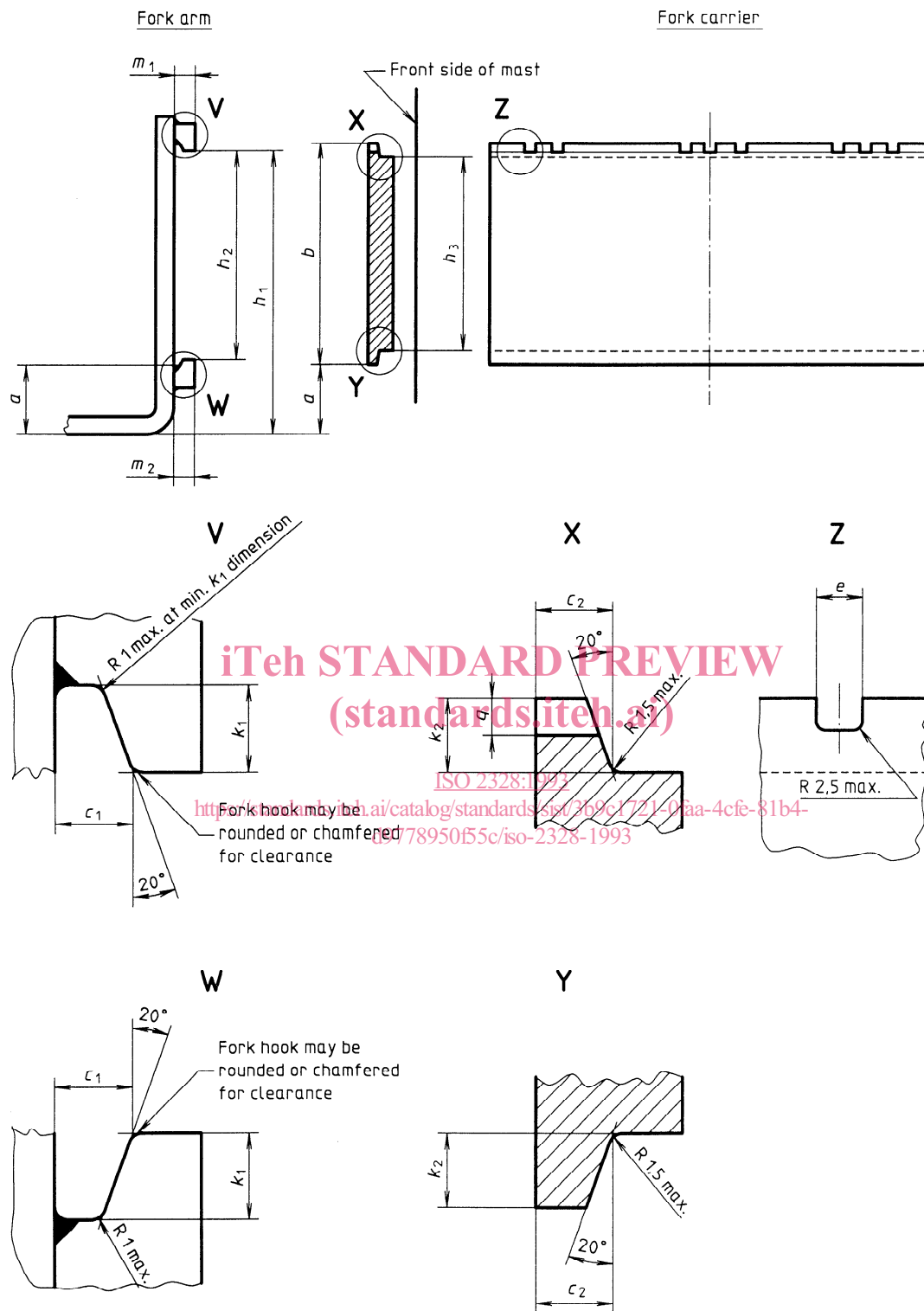

Figure 1 — Fork arm and fork carrier

Table 1 — Mounting dimensions of fork arms

Dimensions in millimetres

Class	Truck rated capacity kg	Rated load centre distance	Fork arm type	a ref.	c <sub>1</sub> <sup>+1</sup> <sub>0</sub>	h <sub>1</sub> ± 3	h <sub>2</sub>		m <sub>1</sub> max.	m <sub>2</sub> max.	k <sub>1</sub> min.
							tol.				
1	up to 999	400	A	76	16,5	394	306	<sup>+1</sup> <sub>0</sub>	28	26	14
			B	114		432					
2	1 000 to 2 500	500	A	76	16,5	470	382	<sup>+1</sup> <sub>0</sub>	31	29	14
			B	152		546					
3	2 501 to 4 999	500	A	76	22	568	477	<sup>+1,5</sup> <sub>0</sub>	40	38	17
			B	203		695					
4	5 000 to 8 000	600	A	127	26	743	598	<sup>+1,5</sup> <sub>0</sub>	47	45	20
			B	254		870					
5	8 001 to 10 999	600	A	127	35	830	680	<sup>+1,5</sup> <sub>0</sub>	65	63	26
			B	257		960					

(standards.iteh.ai)

Table 2 — Mounting dimensions of fork carrier

Dimensions in millimetres

Class	Truck rated capacity kg	Rated load centre distance	Fork arm type	a ref.	b ref.	c <sub>2</sub> <sup>0</sup> <sub>-1</sub>	e ± 0,8	h <sub>3</sub>		k <sub>2</sub> <sup>0</sup> <sub>-1,5</sub>	q <sup>+1</sup> <sub>0</sub>
								tol.			
1	up to 999	400	A	76	331	16	16	305	<sup>0</sup> <sub>-1</sub>	13	8
			B	114							
2	1 000 to 2 500	500	A	76	407	16	16	381	<sup>0</sup> <sub>-1</sub>	13	8
			B	152							
3	2 501 to 4 999	500	A	76	508	21,5	19	476	<sup>0</sup> <sub>-1,5</sub>	16	10
			B	203							
4	5 000 to 8 000	600	A	127	635	25,5	19	597	<sup>0</sup> <sub>-1,5</sub>	19	12
			B	254							
5	8 001 to 10 999	600	A	127	728	34	25	678	<sup>0</sup> <sub>-1,5</sub>	25	16
			B	257							

**iTeh STANDARD PREVIEW**  
**(standards.iteh.ai)**

This page intentionally left blank

ISO 2328:1993

<https://standards.iteh.ai/catalog/standards/sist/3b9c1721-0faa-4cfe-81b4-d9778950f55c/iso-2328-1993>

## iTeh STANDARD PREVIEW

(This page intentionally left blank)

ISO 2328:1993

<https://standards.itih.ai/catalog/standards/sist/3b9c1721-0faa-4cfe-81b4-d9778950f55c/iso-2328-1993>

**iTeh STANDARD PREVIEW**  
**(standards.iteh.ai)**

ISO 2328:1993

<https://standards.iteh.ai/catalog/standards/sist/3b9c1721-0faa-4cfe-81b4-d9778950f55c/iso-2328-1993>

---

---

**UDC 621.868.277**

**Descriptors:** handling equipment, industrial trucks, fork trucks, lift trucks, fork arms, fork carriers, dimensions, mounting dimensions, interchangeability.

Price based on 3 pages

---

---