International Standard



5920

INTERNATIONAL ORGANIZATION FOR STANDARDIZATION • МЕЖДУНАРОДНАЯ ОРГАНИЗАЦИЯ ПО СТАНДАРТИЗАЦИИ • ORGANISATION INTERNATIONALE DE NORMALISATION

Chlorofluorinated hydrocarbons — Determination of water content — Gravimetric method

Hydrocarbures chlorofluorés — Dosage de l'eau — Méthode gravimétrique

First edition — 1983-02-01

ITeH STANDARD PREVIEW
(standards.iteh.ai)

[ISO 5920:1983](#)

<https://standards.iteh.ai/catalog/standards/sist/d3a90968-a97b-41bc-9bec-6ef245497c55/iso-5920-1983>

UDC 661.723 : 543.812

Ref. No. ISO 5920-1983 (E)

Descriptors : hydrocarbons, fluorochlorinated hydrocarbons, tests, determination of content, water, gravimetric analysis, test equipment.

Foreword

ISO (the International Organization for Standardization) is a worldwide federation of national standards bodies (ISO member bodies). The work of developing International Standards is carried out through ISO technical committees. Every member body interested in a subject for which a technical committee has been authorized has the right to be represented on that committee. International organizations, governmental and non-governmental, in liaison with ISO, also take part in the work.

Draft International Standards adopted by the technical committees are circulated to the member bodies for approval before their acceptance as International Standards by the ISO Council.

International Standard ISO 5920 was developed by Technical Committee ISO/TC 47, *Chemistry*, and was circulated to the member bodies in November 1981.

It has been approved by the member bodies of the following countries :

Austria	Germany, F.R.	Portugal
Belgium	India	Romania
Brazil	Italy	South Africa, Rep. of
Czechoslovakia	Korea, Rep. of	Switzerland
Egypt, Arab Rep. of	Netherlands	Thailand
France	Poland	USSR

The member body of the following country expressed disapproval of the document on technical grounds :

United Kingdom

Chlorofluorinated hydrocarbons — Determination of water content — Gravimetric method

1 Scope and field of application

This International Standard specifies a gravimetric method for the determination of the water content of chlorofluorinated hydrocarbons having boiling temperatures up to about 4 °C.

The method is applicable to products having water contents in the range 2 to 100 mg/kg.

2 References

ISO 383, *Laboratory glassware — Interchangeable conical ground joints*.

ISO 3427, *Gaseous halogenated hydrocarbons (liquefied gases) — Taking of a sample*.

3 Principle

Passage of a vaporized test portion, comprising the entire laboratory sample, through two weighed absorption tubes containing a phosphorus(V) oxide absorption mixture.

Calculation of the water content from the increase in mass of the absorption tubes.

4 Sampling

Transfer from the liquid phase, into a stainless steel cylinder, a laboratory sample of mass between 600 and 1 000 g, using the procedure specified in ISO 3427. Take a similar sample in another cylinder to use in conditioning the absorption tubes (see 7.3.2).

5 Reagent and materials

5.1 Phosphorus(V) oxide absorption mixture.

Mix 2 parts of diatomaceous earth (kieselguhr) with 1 part of phosphorus(V) oxide, adding a small quantity of silicagel, coloured with a cobalt salt, as indicator.

5.2 Glass wool.

5.3 Compressed air.

6 Apparatus

Ordinary laboratory apparatus and

6.1 Apparatus comprising the following components, a typical arrangement of which is shown, as an example, in figure 1.

6.1.1 Two absorption tubes (see figure 2), each of length about 75 mm and external diameter about 12 mm, and fitted with 7/11 ground glass joints complying with the requirements of ISO 383. One of the two tubes terminates in a capillary outlet tube of length about 15 mm and internal diameter 1 mm (external diameter of the capillary about 8 mm).

The two tubes are connected in series in the apparatus (see figure 1). A ground glass stopper is used to close the non-capillary end of the connected absorption tubes, when they are not in use.

6.1.2 Liquid trap (see figure 3), of capacity about 40 ml, with 7/11 ground glass joints.

6.1.3 Needle valve (see figure 4), having a poly(tetrafluoroethylene) (PTFE) conical joint which fits the ground glass joint of the liquid trap (6.1.2) (see figure 1).

6.1.4 Gas meter, water displacement type, 1 litre per revolution, with a poly(tetrafluoroethylene) (PTFE) joint to connect it to the absorption tubes (6.1.1), for use when the test portion is measured by volume.

6.1.5 Connector, made of PTFE, linking the absorption tubes assembly (6.1.1) to the gas meter (6.1.4).

6.2 Scavenging apparatus for the absorption tubes (6.1.1) (see figures 5 and 6), comprising the following components.

6.2.1 Pressure regulators, to adjust the pressure of the compressed air (5.3) from which it may be fed, via a capillary tube of internal diameter 1 mm and external diameter about 8 mm, to the drying cartridge (6.2.2).

6.2.2 Drying cartridge (see figure 5) consisting of a transparent acrylic plastics tube, about 300 mm long and about 20 mm external diameter, which contains similar quantities, adjacently packed, of

- the phosphorus(V) oxide absorption mixture (5.1),
- molecular sieve type 5A, to remove final traces of water and oil.

The scavenging apparatus shall be connected on the left-hand side of the absorption tubes assembly.

NOTE — In operation, the air passes first through the absorption mixture.

6.3 Electric oven, capable of being controlled at 105 ± 2 °C.

6.4 Desiccator, containing phosphorus(V) oxide.

7 Procedure

7.1 General precautions

Protect all parts of the apparatus (6.1) leading to the gas meter (6.1.4) from contamination with atmospheric moisture. In particular, minimize exposure to the atmosphere of the absorption tubes (6.1.1), the liquid trap (6.1.2) and the drying cartridge (6.2.2), when connecting these components together.

Store the liquid trap, when not in use, in the oven (6.3) controlled at 105 ± 2 °C; remove it and allow it to cool to ambient temperature in the desiccator (6.4) before assembling the apparatus.

Carry out the whole procedure in a well ventilated fume cupboard.

7.2 Test portion

Use as test portion the entire laboratory sample (see clause 4). Determine its mass either by weighing, to the nearest 1 g, the mass of the sampling cylinder before and after the determination or by measurement of the volume of the vaporized test portion.

7.3 Preparation of the absorption tubes

7.3.1 Filling

Fill the absorption tubes (6.1.1) with the phosphorus(V) oxide absorption mixture (5.1) placed between two plugs of the glass wool (5.2).

Connect the absorption tubes, stopper the left-hand inlet and, when not in use, store them in the desiccator (6.4).

7.3.2 Conditioning and weighing

Connect another sampling cylinder of the product under examination (see clause 4) to the absorption tubes assembly and allow the vaporized product to pass through this assembly for about 10 min at a rate of about 200 to 300 ml/min. Replace the cylinder by the scavenging apparatus and, using the same conditions, pass a similar quantity of dry air through the assembly. Disconnect the assembly, stopper it and allow it to stand in an enclosed space (for example a balance case) for about 10 min. Weigh the stoppered assembly to the nearest 0,000 1 g. Repeat the treatment with dry air and weighing until the difference between two successive weighings does not exceed 0,000 2 g.

7.4 Assembly of the apparatus

Replace the needle valve of the sampling cylinder (see ISO 3427) by the needle valve (6.1.3). Weigh the cylinder if the mass of the test portion is to be determined by mass difference. Connect the sampling cylinder to the liquid trap (6.1.2). Connect the weighed absorption tubes (see 7.3.2) to the outlet of the liquid trap and to the inlet of the gas meter (6.1.4), if used, by means of the PTFE connector (see figure 1).

NOTE — If the product under examination has a high boiling point, for example 1,2-dichloro-1,1,2,2-tetrafluoroethane (R 114), it may be necessary to provide means of heating the liquid trap during the determination (a current of warm air is suitable).

7.5 Determination

Before starting the analysis, note the reading of the gas meter (6.1.4), if used, and the ambient temperature and pressure.

Adjust the needle valve so that the gas passes through the apparatus at a rate of 0,6 to 1,0 l/min. After the test portion (7.2) has passed through the apparatus, close the needle valve and note the reading on the gas meter, if used; otherwise disconnect the sampling cylinder and weigh it.

NOTE — In the case of chlorodifluoromethane (R 22) (where the water content of the liquid phase greatly exceeds that of the vapour phase), invert the sampling cylinder during the determination so as to minimize any error due to incomplete evaporation of the water-rich liquid phase.

Disconnect the absorption tubes assembly and connect it to the scavenging apparatus (6.2) (see figure 6). Pass a current of 200 to 300 ml of dry air through this assembly in about 1 min so as to remove any gaseous traces of the test portion.

Disconnect the absorption tubes assembly, stopper it, and allow it to stand in a balance case for 10 min. Weigh the stoppered assembly to the nearest 0,000 1 g.

NOTE — Replace the phosphorus(V) oxide absorption mixture in the absorption tubes when about half the contents of the tubes have changed colour, usually after three to five determinations.

8 Expression of results

8.1 Test portion measured by volume

8.1.1 Correction of volume

The volume of the test portion, V_0 , corrected to standard conditions (273 K and 1 013 mbar), is given by the formula

$$V_0 = \frac{\Delta V \times p_1 \times T_0}{p_0 \times T_1}$$

where

V_0 is the volume corrected to standard conditions;

ΔV is the difference in volume, expressed in litres, between the readings of the gas meter before and after the determination;

p_0 is the standard barometric pressure, in millibars (1 013 mbar);

p_1 is the barometric pressure, in millibars, during the determination;

T_0 is the standard thermodynamic temperature, in kelvins, (273 K);

T_1 is the thermodynamic temperature, in kelvins, during the determination.

8.1.2 Calculation of water content

The water content, expressed in milligrams per kilogram, is given by the formula

$$\frac{m_2 - m_1}{m_0}$$

where

m_0 is the mass, in kilograms, of the test portion, i.e. $V_0 \cdot \rho$

where

V_0 is as defined in 8.1.1,

ρ is the density, in kilograms per litre, of the gaseous product under standard conditions;

m_1 is the mass, in milligrams, of the two absorption tubes before the determination;

m_2 is the mass, in milligrams, of the two absorption tubes after the determination.

8.2 Test portion measured by mass

The water content, expressed in milligrams per kilogram, is given by the formula

$$\frac{m_2 - m_1}{m_3}$$

where

m_1 and m_2 are as defined in 8.1.2;

m_3 is the mass, in kilograms, of the test portion, obtained by difference from the masses of the sample cylinder before and after the determination.

9 Test report

The test report shall include the following particulars :

- an identification of the sample;
- the reference of the method used;
- the results and the method of expression used;
- any unusual features noted during the determination;
- any operation not included in this International Standard or in ISO 3427 to which reference is made, or regarded as optional.

iTeh STANDARD PREVIEW
(standards.iteh.ai)

ISO 5920:1983

<https://standards.iteh.ai/catalog/standards/sist/42e00968-c971-411b-9ba6-6ef245497c55/iso-5920-1983>

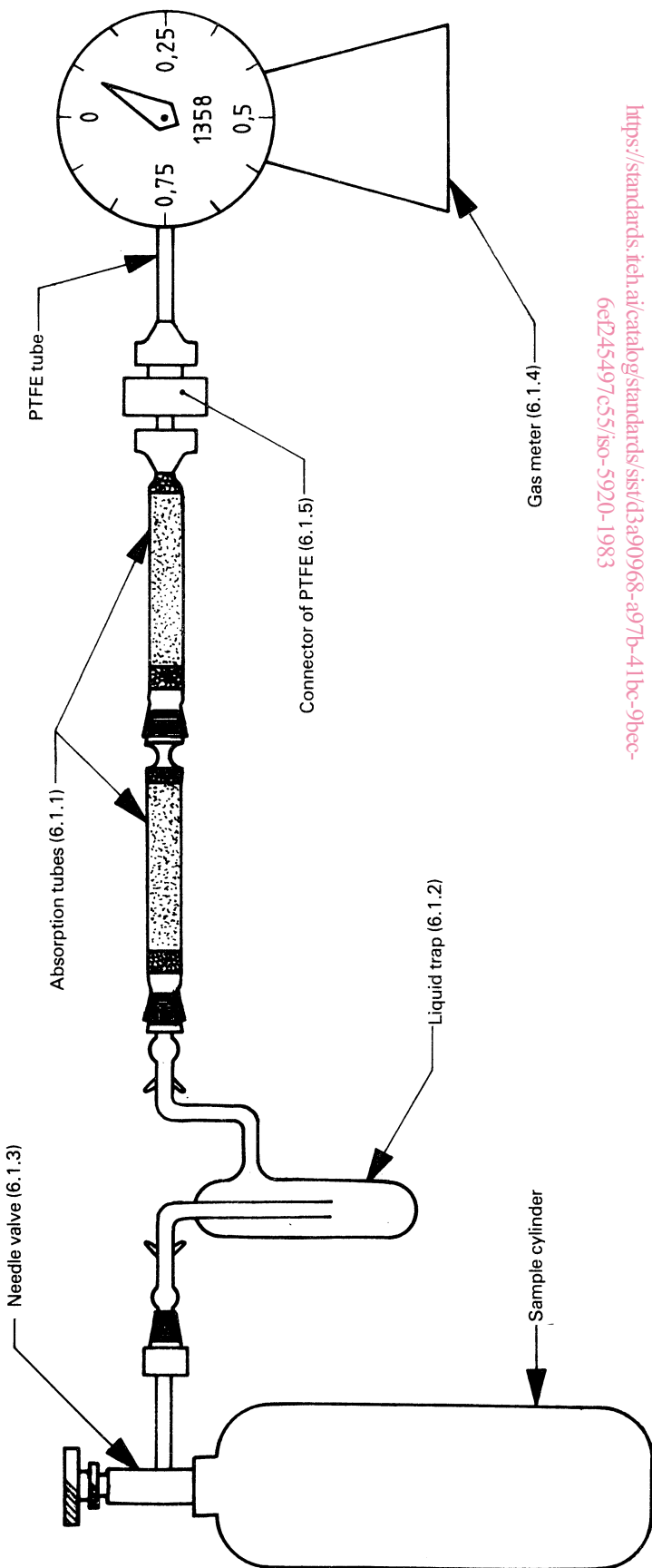

Figure 1 — Arrangement of apparatus

ISO 5920:1983
<https://standards.iteh.ai/catalog/standards/sist/d3a90968-a97b-41bc-9bec-6ef245497c55/iso-5920-1983>

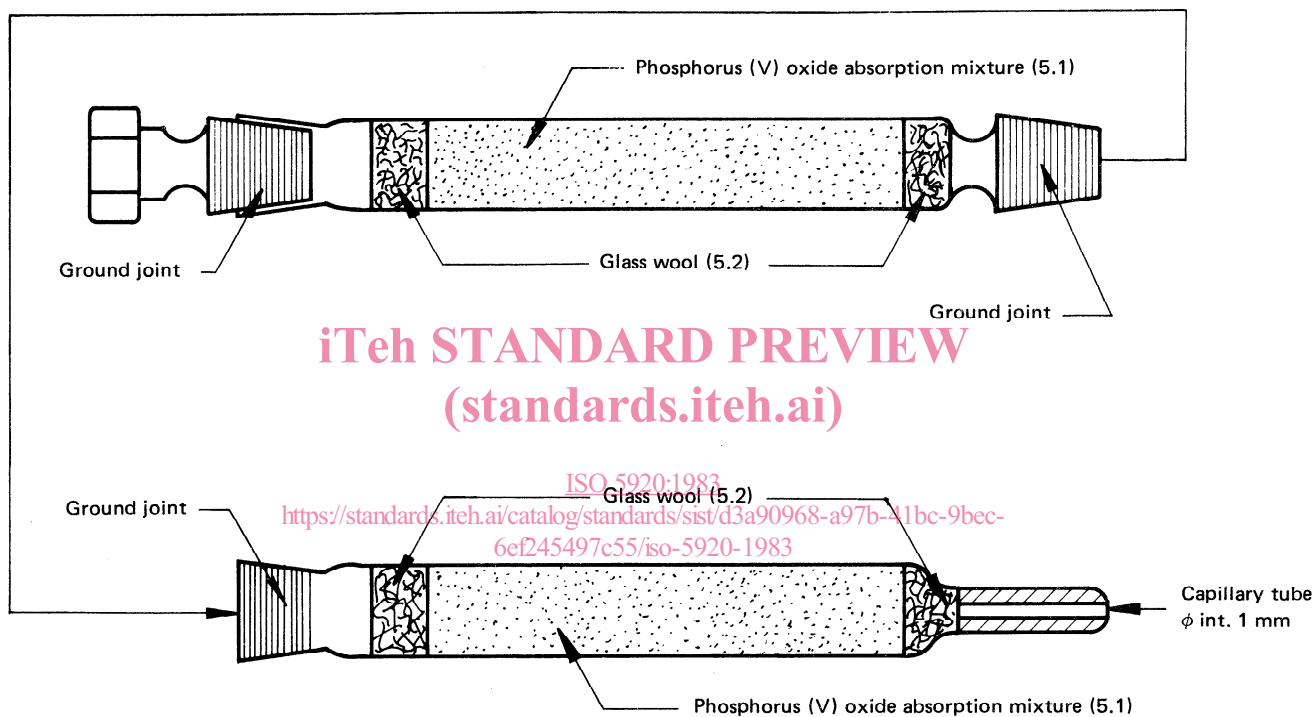
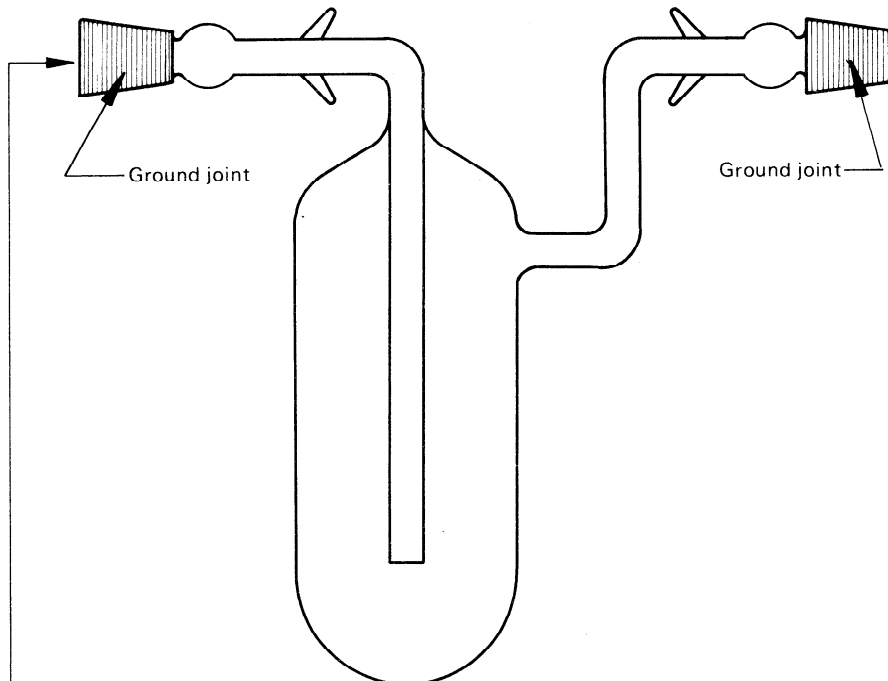
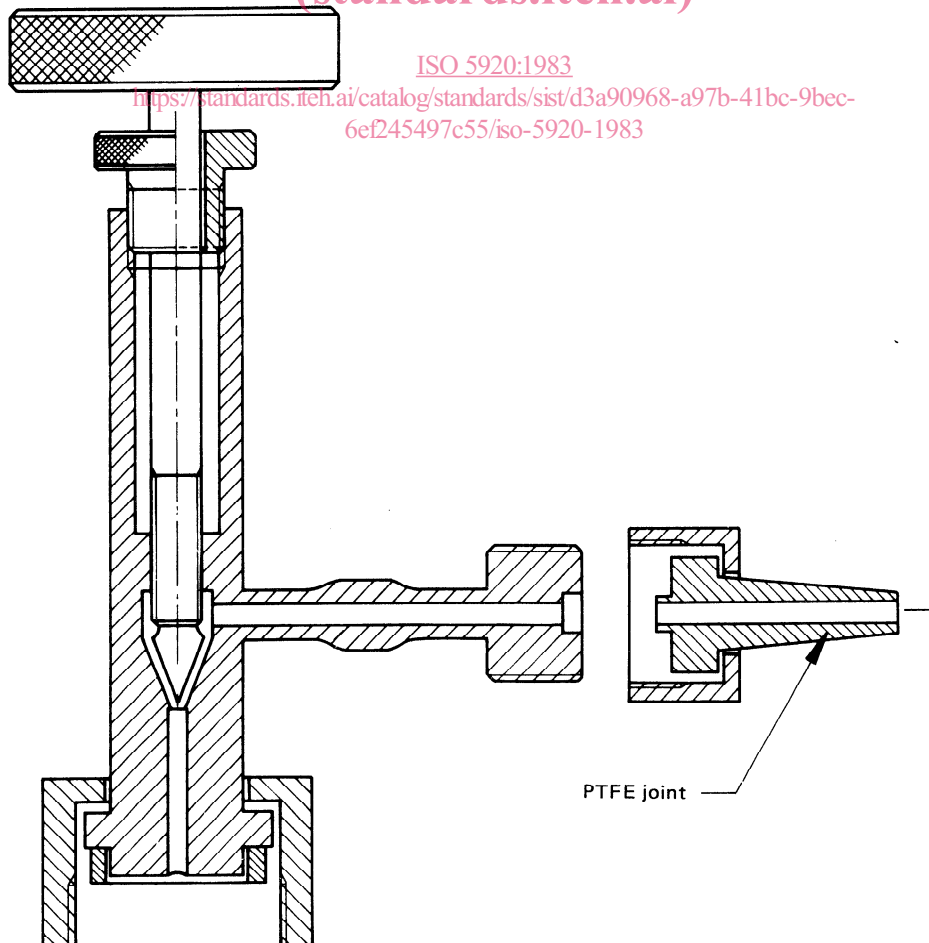

Figure 2 — Absorption tubes (6.1.1)



iTeh STANDARD PREVIEW
Figure 3 — Liquid trap (6.1.2)
(standards.iteh.ai)



ISO 5920:1983

<https://standards.iteh.ai/catalog/standards/sist/d3a90968-a97b-41bc-9bec-6ef245497c55/iso-5920-1983>

Figure 4 — Needle valve (6.1.3)

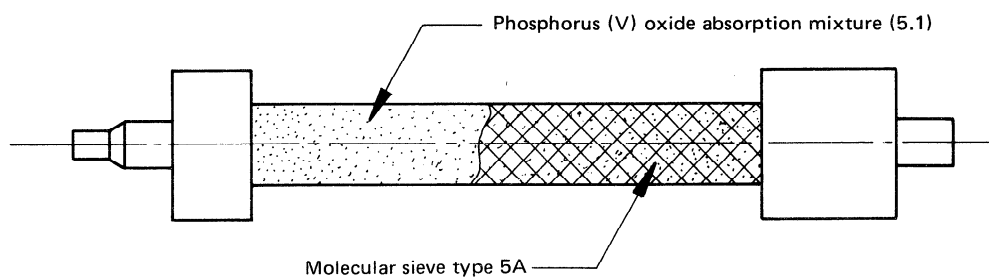

Figure 5 — Drying cartridge (6.2.2)

iTeh STANDARD PREVIEW (standards.iteh.ai)

ISO 5920:1983

<https://standards.iteh.ai/catalog/standards/sist/d3a90968-a97b-41bc-9bec-6ef245497c55/iso-5920-1983>

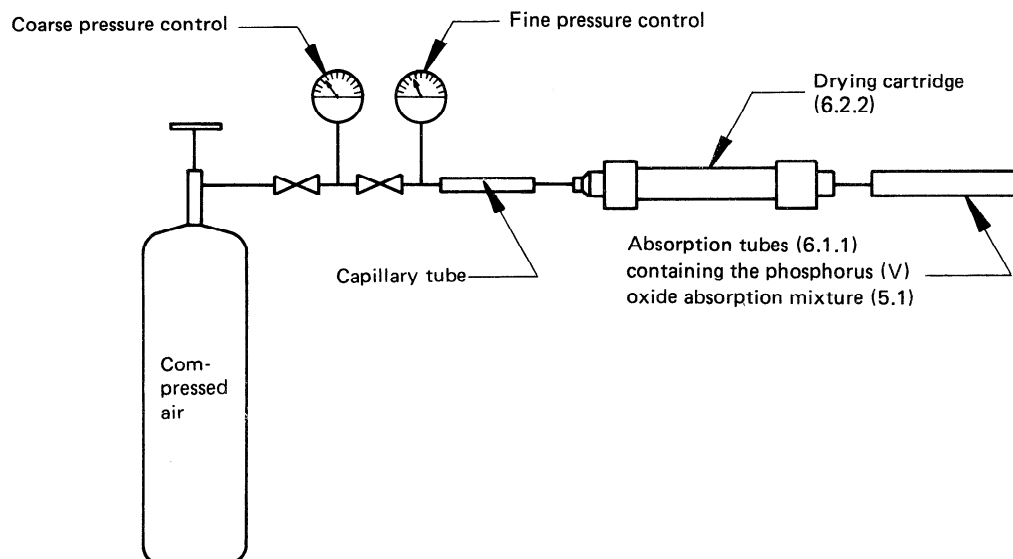

Figure 6 — Scavenging of absorption tubes