International Standard



5925/1

INTERNATIONAL ORGANIZATION FOR STANDARDIZATION • МЕЖДУНАРОДНАЯ ОРГАНИЗАЦИЯ ПО СТАНДАРТИЗАЦИИ • ORGANISATION INTERNATIONALE DE NORMALISATION

**Fire tests — Evaluation of performance of smoke control
door assemblies —
Part 1 : Ambient temperature test**

Essais au feu — Évaluation de performance des ensembles-portes pare-fumée — Partie 1 : Essai à la température ambiante

First edition — 1981-11-01

ITeH STANDARD PREVIEW
(standards.iteh.ai)

ISO 5925-1:1981

<https://standards.iteh.ai/catalog/standards/sist/3c1e0a8f-9ffd-4ad7-a270-29bb282539b6/iso-5925-1-1981>

UDC 69.028.1 : 699.81 : 620.1

Ref. No. ISO 5925/1-1981 (E)

Descriptors : construction materials, fire tests, fire-stop doors, results, specimens.

Foreword

ISO (the International Organization for Standardization) is a worldwide federation of national standards institutes (ISO member bodies). The work of developing International Standards is carried out through ISO technical committees. Every member body interested in a subject for which a technical committee has been set up has the right to be represented on that committee. International organizations, governmental and non-governmental, in liaison with ISO, also take part in the work.

Draft International Standards adopted by the technical committees are circulated to the member bodies for approval before their acceptance as International Standards by the ISO Council.

International Standard ISO 5925/1 was developed by Technical Committee ISO/TC 92, *Fire tests on building materials, components and structures*, and was circulated to the member bodies in February 1980.

It has been approved by the member bodies of the following countries:

Australia	Ireland	Romania
Belgium	Israel	South Africa, Rep. of
Brazil	Italy	Spain
Czechoslovakia	Japan	Sweden
Denmark	Korea, Rep. of	Switzerland
Egypt, Arab Rep. of	Netherlands	United Kingdom
Finland	New Zealand	
Germany, F. R.	Norway	

The member bodies of the following countries expressed disapproval of the document on technical grounds :

Austria
France
Hungary
USA

Fire tests — Evaluation of performance of smoke control door assemblies — Part 1 : Ambient temperature test

iTeh STANDARD PREVIEW (standards.iteh.ai)

0 Introduction

This method of test is one of a series for the assessment and evaluation of performance of door and shutter assemblies intended to act as barriers to smoke in a fire. The severity of the heat exposure conditions governs the smoke control performance of doors and this has led to the preparation of a series of test methods. Further explanation and guidance on this and other considerations will form the subject of ISO 5925/0.

Further tests in the series will form the subjects of :

ISO 5925/2, *Fire tests — Evaluation of performance of smoke control door assemblies — Part 2 : Medium temperature test.*

ISO 5925/3, *Fire tests — Evaluation of performance of smoke control door assemblies — Part 3 : High temperature test.*

1 Scope and field of application

This International Standard specifies a method of testing and evaluating the performance of door assemblies and shutters, intended to control the passage of smoke in ambient conditions.

2 References

ISO 1804, *Doors — Terminology.*

ISO 3008, *Fire resistance tests — Door and shutter assemblies.*

ISO 3261, *Fire tests — Vocabulary.*

3 Definitions

For the purpose of this International Standard, the definitions given in ISO 1804 and ISO 3261, together with the following, apply.

3.1 door assembly; doorset : An assembly consisting of a fixed part (the door frame), one or more movable parts (the door leaves), and their hardware, the function of which is to allow or to prevent access.

3.2 smoke control door : A door assembly whose primary function is to resist the passage of smoke.

3.3 ambient temperature : A temperature of 25 ± 15 °C, representative of that normally found in buildings.

4 Principle

Determination of the rate of flow of air from the high to the low pressure side of a door assembly.

When smoke from a fire starts to spread, a pressure difference can develop between the two sides of a door assembly. Leakage of smoke can occur through the clearance between the door leaf and the frame and other openings. This test simulates the conditions which may be experienced in practice by doors during the very early stages of fire development, or by doors remote from the seat of a fire.

5 Apparatus

The basic test apparatus consists of the following :

- a) an air leakage test chamber with one side open and a surround into which a door assembly can be built; the surround shall be capable of being fixed and sealed against the opening (see figure 1);
- b) a means of providing a differential air pressure across the specimen;
- c) a means of measuring the rate of flow of air by volume, into or out of the apparatus;
- d) a means of measuring the differences in pressure between the two faces of the test specimen.

5.1 Test chamber

The test chamber shall be so constructed that when the opening in the surround is sealed, the rate of air leakage shall not exceed 1 m³/h at 100 Pa¹⁾. (An example of a suitable design for the test chamber is shown in figure 1.)

The chamber shall be equipped with :

- a) a fan system capable of applying and maintaining a pressure differential of 100 Pa¹⁾ between the two faces of the door;
- b) connections to provide for the supply to and exhaustion of air from the chamber, and a means of ensuring that the air flow pattern in the chamber gives a uniform pressure at the face of the door²⁾ in order to comply with the requirements of 5.2 and 7.3.

The chamber may be fitted with a reversible air flow system (see figure 2).

5.2 Pressure measuring equipment

The static pressure difference between the two faces of the door assembly shall be measured by suitable pressure measuring equipment, capable of measuring over a range from 5 to 100 Pa with an accuracy of $\pm 10\%$ of the specified value, with a maximum limit of ± 5 Pa.

The atmospheric pressure shall be measured with an accuracy of $\pm 1\%$.

5.3 Air flow measuring equipment

The test chamber shall be provided with instrumentation for measuring³⁾ the rate of air leakage when the test door or shutter is in place. The air flow measuring equipment shall be capable of measuring the rate of air leakage with an accuracy of $\pm 5\%$. It may be necessary to use more than one instrument to achieve the required accuracy.

6 Preparation of test specimens

6.1 Construction

The test shall be performed on a complete door assembly as intended to be used in practice, incorporating all hardware and other equipment⁴⁾. The finish and form of the specimen shall be representative of the finish and form of the door as installed in its intended position of use.

The mounting of the specimen shall be representative of its use in practice so that appropriate clearances between the door leaves and the frame or the surround exist. The clearance between the door edge and frame shall be measured at three positions along each edge.

Before measuring the air leakage, any joint or clearance between the frame of the door assembly and its surround shall be sealed.

When the specimen is examined in a surround intended for the determination of fire resistance, additional requirements, specified in sub-clause 5.2 of ISO 3008, also apply. Attention shall be paid to the sealing of the surface of this surround.

6.2 Conditioning

Specimens containing hygroscopic materials or other materials which can be affected by moisture shall be conditioned to equilibrium with the prevailing conditions in the laboratory which shall be within the following limits :

temperature (dry bulb) :	25 \pm 15 °C;
relative humidity :	40 to 65 %.

Door assemblies made entirely of metal or of metal and glass do not require conditioning.

1) 1 Pa = 1 N/m² (approximately 0,1 mm water gauge).

2) This may be achieved by means of baffles or deflection.

3) In general, the rate of air leakage will depend upon the size of the door and the area of the leakage paths. It is not anticipated that the rate of air leakage will exceed 16 m³/h per metre of the leakage path for doors designed for smoke control purposes.

4) The term "hardware" includes such items as hinges, latches, door handles, locks, keyholes (excluding keys), letter plates, sliding gear, closing devices, electrical wiring and any other items which may influence the performance of the specimen being tested.

7 Procedure

7.1 Test conditions

The test shall be carried out in the conditions specified in 6.2.

7.2 Operational test

After installation of the door assembly, and with the surround in position in the test chamber, open and close each leaf or moving element of the assembly ten times, using the automatic closer if provided, to ensure that the assembly operates normally.¹⁾

7.3 Air leakage test for the apparatus

Both before and after the series of pressure measurement readings, determine the air leakage of the apparatus by blocking off or sealing the door and taking measurements at the required test pressure differentials.

The leakage rate corrected for standard conditions (see clause 8) of the apparatus shall not be more than 1 m³/h at 100 Pa (see 5.1).

7.4 Air leakage test for the door assembly

7.4.1 The door shall be mounted in its frame in accordance with clause 6 and shall be tested in the closed position. The door assembly shall normally be tested from both sides²⁾.

7.4.2 If information is required about the contribution to total rate of air leakage made by the threshold only, test the door assembly with the gap at sill level unsealed and then impermeably sealed.

7.4.3 Place the probes for sensing the inside of the chamber at a distance of 100 ± 10 mm from the plane of a single leaf door, one at the top and one at the bottom of the door along its vertical axis, or, in the case of a double leaf door, one at the top centre of one door and one at the bottom centre of the other (see figure 3).

7.4.4 Proceed as follows.

- Measure the barometric pressure (P_a), the temperature (T_a) and the relative humidity (M_w) of the air in the laboratory.
- Start the fan and note the airflow.
- Establish the pressure differential at the intended level ± 2 Pa at the two measuring points specified in 7.4.3.
- As soon as the test conditions have been stable for at least 3 min, measure the total rate of air leakage through the door assembly.

7.4.5 Measure the air leakage at accurately known pressure differentials that approximate to 5 – 10 – 20 – 30 – 50 – 70 and 100 Pa, up to the maximum pressure differential for which information is required, and then again at 5 Pa. Then measure the air leakage once more at the maximum pressure differential.

8 Expression of results

The following information shall be recorded for each pressure differential, expressed as a mean of two readings, and adjusted to a reference temperature of 20 °C and standard atmospheric pressure :

- rate of air leakage for the apparatus;
- total rate of air leakage.

The adjustment to standard reference conditions is defined by dry air at a temperature of 20 °C (293,15 K) and at a pressure of 1 atmosphere (101 325 Pa).

The adjusted air flow rate Q'_a is given (very closely) by :

$$Q'_a = Q_a \times \frac{(P_a + \Delta p)}{101\,325} \times \frac{293,15}{(T_a + 273,15)} \times \left[1 - \left(0,379\,5 \times \frac{M_w}{100} \times \frac{E_s}{P_a + \Delta p} \right) \right]$$

where

- Q_a is the measured air flow rate;
- P_a is the barometric pressure, in pascals;
- Δp is the pressure increase, in pascals;
- T_a is the air temperature, in degrees Celsius;
- M_w is the relative humidity, as a percentage;
- E_s is the saturated water vapour pressure, in pascals.

As an example, if measurements are made when the air is at 27 °C (300,15 K), the barometric pressure is 102 000 Pa, the pressure increase is 30 Pa, and the relative humidity of the air is 50 % (saturation water vapour pressure = 3 567 Pa), then

$$Q'_a = Q_a \times \frac{102\,030}{101\,325} \times \frac{293,15}{300,15} \times \left[1 - \left(0,379\,5 \times \frac{50}{100} \times \frac{3\,567}{102\,030} \right) \right] = 0,977 Q_a$$

1) This procedure is not intended to be a durability test representing the wear and tear normally found in use.

2) To meet special circumstances, or if it can be ascertained by observation that leakage through the door from one side to the other is likely to be significantly higher than that in the reverse direction, the testing authority may decide to test a single assembly with the direction of air flow from that direction only.

9 Test report

The test report shall include the following information :

- a) the name of the testing laboratory;
- b) the name of the sponsor;
- c) the date of test;
- d) the name of the manufacturer, and the trade-name and model number (if any) of the product;
- e) details of the construction and physical characteristics, conditioning of the specimen, together with drawings (clearances and gaps between the door and the frame shall be fully recorded);
- f) a description of the test apparatus including the measuring system and, if applicable, the direction of air flow with reference to the door assembly;
- g) a description of the fixing of the specimen to the surrounding wall and of the joint, if any, between the door assembly and the surrounding wall;
- h) a description of glazing, if any;
- j) the side of the door which was tested;
- k) the test results.

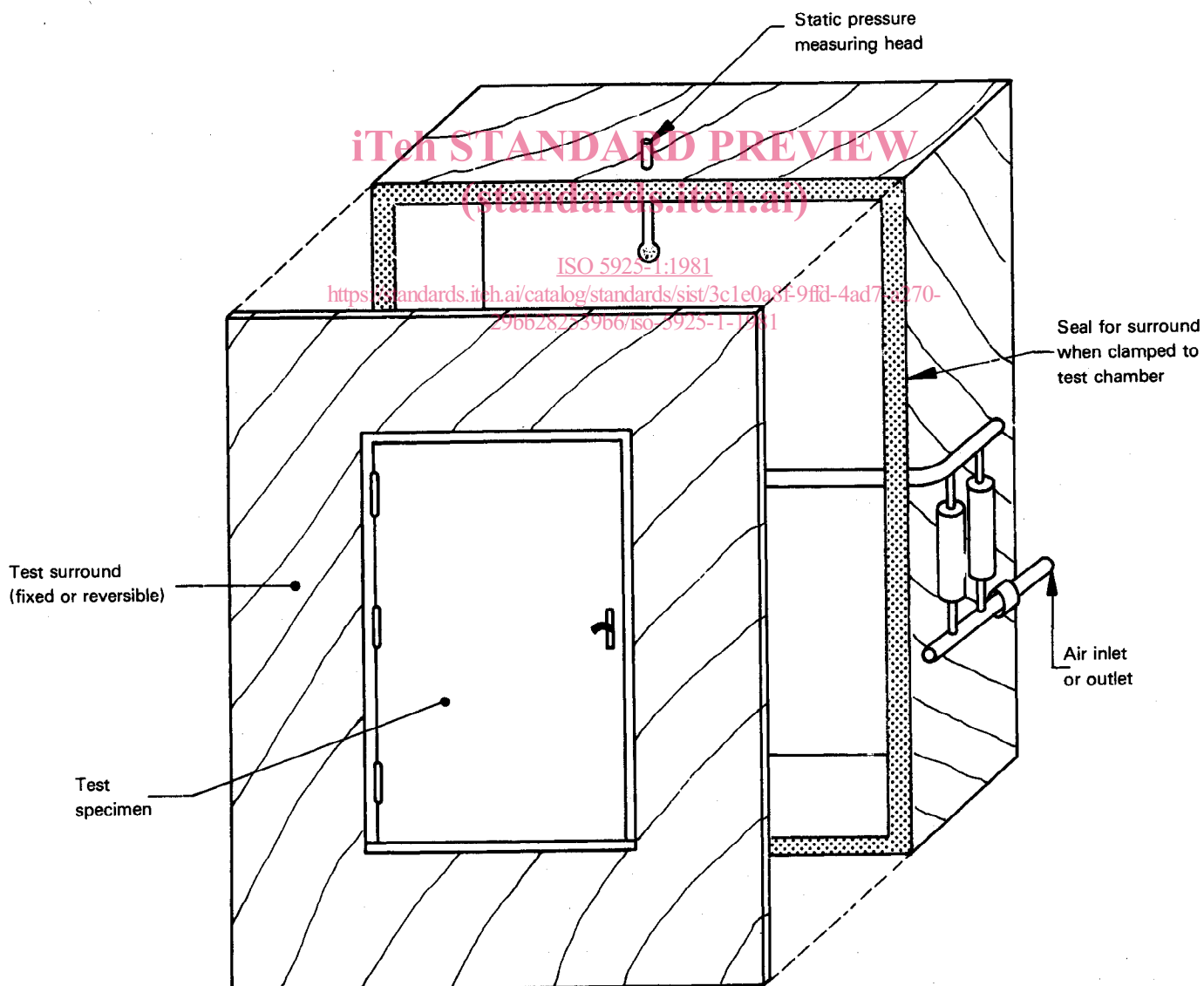
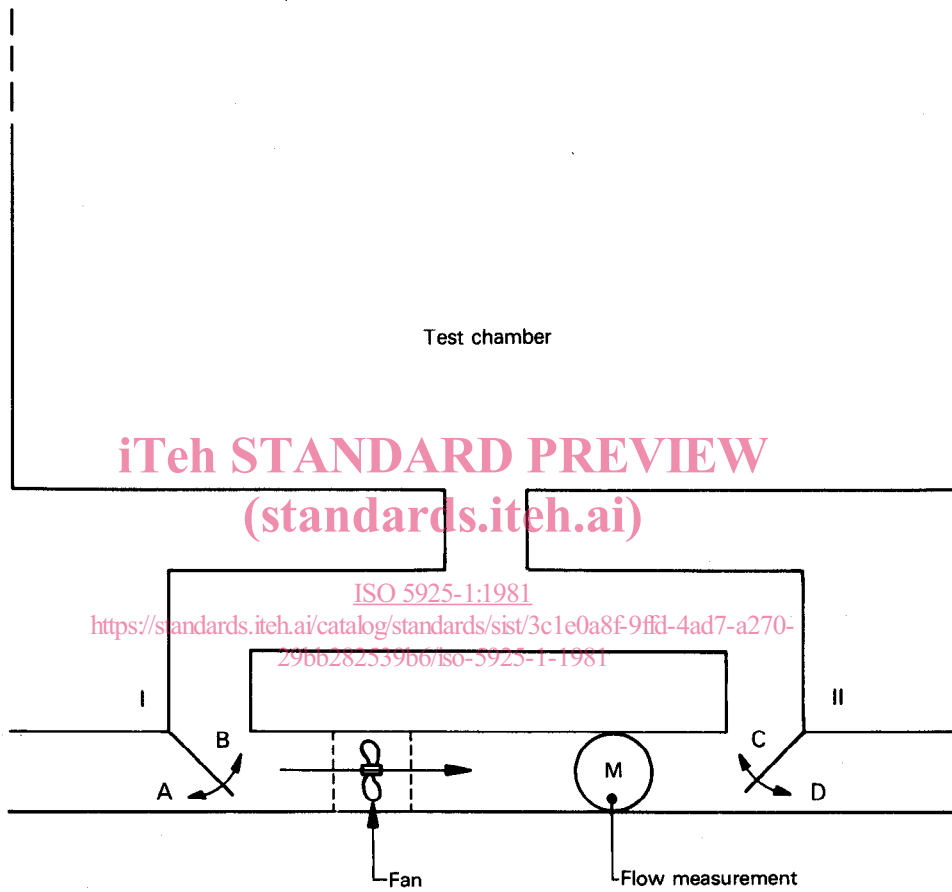

Figure 1 — Example of an air leakage test chamber designed to test different sized door assemblies in a reversible frame



Overpressure : baffle I in position B
 baffle II in position D

Underpressure : baffle I in position A
 baffle II in position C

Figure 2 — Diagrammatic representation of a reversible air flow system

Dimensions in millimetres

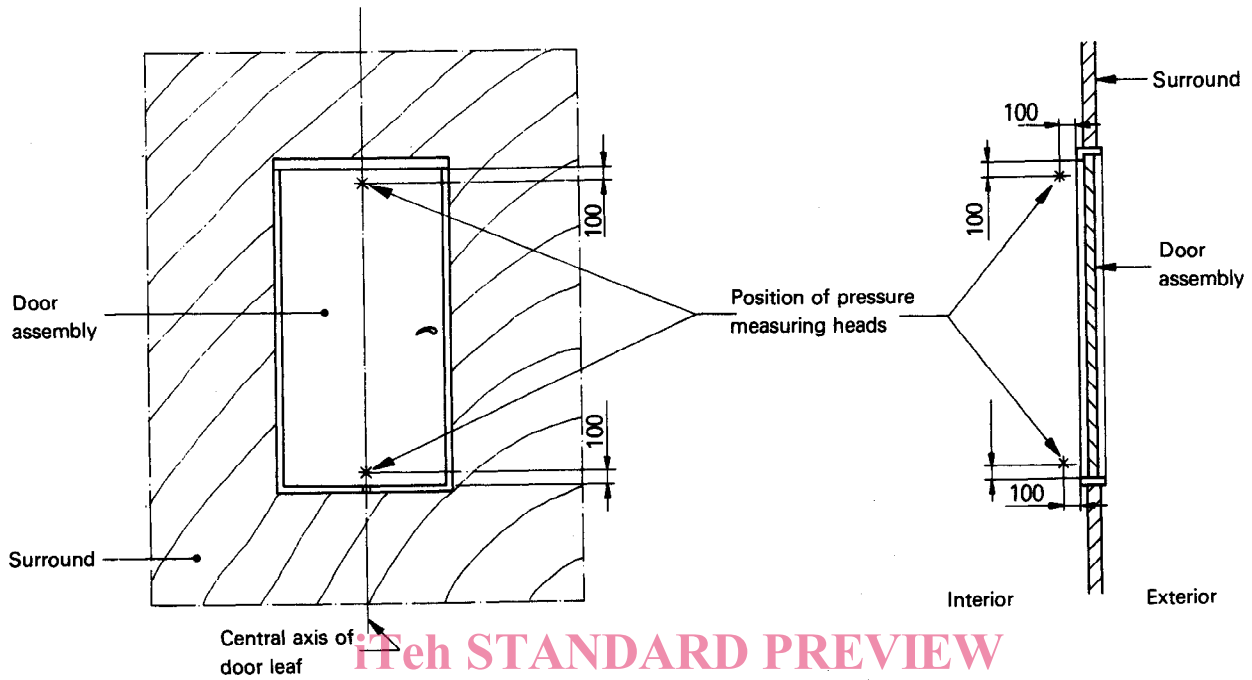

iteh STANDARD PREVIEW
(standards.iteh.ai)

ISO 5925-1:1981

<https://standards.iteh.ai/catalog/standards/sist/3c1e0a8f-9ffd-4ad7-a270-29bb282539b6/iso-5925-1-1981>

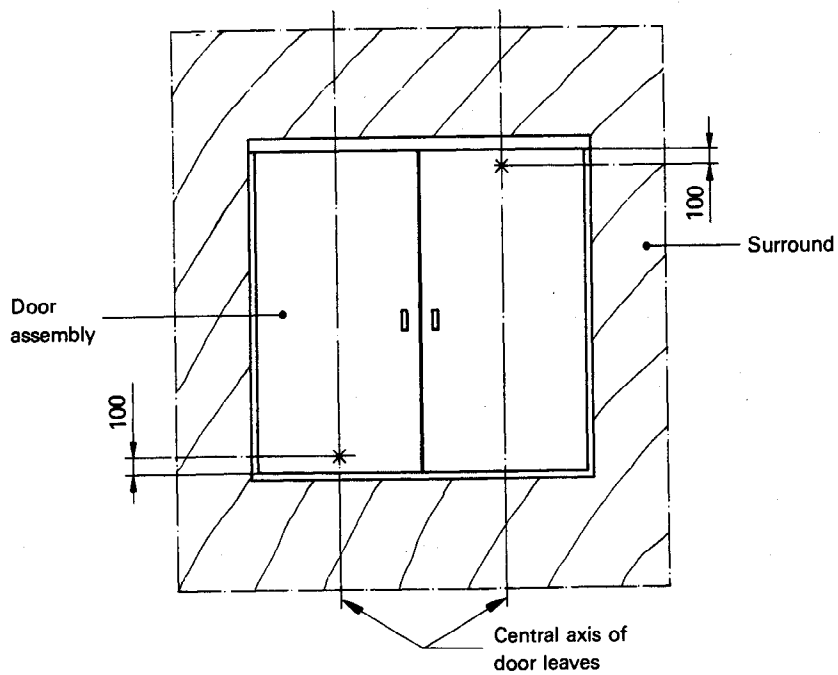

Figure 3 – Position of pressure measuring heads on interior of test chamber