

INTERNATIONAL STANDARD

ISO 6015

First edition
1989-10-15

Earth-moving machinery — Hydraulic excavators — Methods of measuring tool forces

*Engins de terrassement — Pelles hydrauliques — Méthodes de mesure des forces
de l'outil*



Reference number
ISO 6015 : 1989 (E)

<https://standards.iteh.ai/catalog/standards/sist/471e8a21-4852-4832-b93-1d897915b59b/iso-6015-1989>

ISO 6015:1989

ITEH STANDARD PREVIEW
(standards.iteh.ai)

Foreword

ISO (the International Organization for Standardization) is a worldwide federation of national standards bodies (ISO member bodies). The work of preparing International Standards is normally carried out through ISO technical committees. Each member body interested in a subject for which a technical committee has been established has the right to be represented on that committee. International organizations, governmental and non-governmental, in liaison with ISO, also take part in the work. ISO collaborates closely with the International Electrotechnical Commission (IEC) on all matters of electrotechnical standardization.

Draft International Standards adopted by the technical committees are circulated to the member bodies for approval before their acceptance as International Standards by the ISO Council. They are approved in accordance with ISO procedures requiring at least 75 % approval by the member bodies voting.

International Standard ISO 6015 was prepared by Technical Committee ISO/TC 127, *Earth-moving machinery*.

This first edition cancels and replaces the first edition of part 1 (ISO 6015-1 : 1986), 3.4.1, 3.4.2, 3.5.1 (and therefore terms used in clauses 6 and 7) and 8.1.1e) of which have been technically revised.

© ISO 1989

All rights reserved. No part of this publication may be reproduced or utilized in any form or by any means, electronic or mechanical, including photocopying and microfilm, without permission in writing from the publisher.

International Organization for Standardization
Case postale 56 • CH-1211 Genève 20 • Switzerland

Printed in Switzerland

Earth-moving machinery — Hydraulic excavators — Methods of measuring tool forces

1 Scope

This International Standard specifies methods for determining the tool forces of hydraulic excavators, together with their limiting conditions. It applies to all types of hydraulic excavators, crawler or wheeled machines, and with or without outriggers, as defined in ISO 6165.

2 Normative references

The following standards contain provisions which, through reference in this text, constitute provisions of this International Standard. At the time of publication, the editions indicated were valid. All standards are subject to revision, and parties to agreements based on this International Standard are encouraged to investigate the possibility of applying the most recent editions of the standards listed below. Members of IEC and ISO maintain registers of currently valid International Standards.

ISO 6016 : 1982, *Earth-moving machinery — Methods of measuring the masses of whole machines, their equipment and components.*

ISO 6165 : 1987, *Earth-moving machinery — Basic types — Vocabulary.*

ISO 6746-1 : 1987, *Earth-moving machinery — Definitions of dimensions and symbols — Part 1: Base machine.*

ISO 7451 : 1983, *Earth-moving machinery — Hydraulic excavators — Hoe type buckets — Volumetric ratings.*

ISO 7546 : 1983, *Earth-moving machinery — Loader and front loading excavator buckets — Volumetric ratings.*

3 Definitions

For the purposes of this International Standard, the following definitions apply.

3.1 tool forces: On an excavator fitted with a hoe or shovel, tool forces are the actual forces generated at the bucket lip when operating the bucket or arm cylinder independently.

For buckets with a curved or pointed cutting edge the forces shall be measured at the centre of the bucket width.

The direction of the tool forces to be measured shall be tangential to the arc described by the bucket lip.

3.2 grab and clamshell closing force: Maximum force available between the clamshells at the cutting edge or the tips of the teeth when closing.

3.3 mass: Operating mass of the machine, as defined in ISO 6016.

3.4 Hydraulic pressure

3.4.1 working circuit pressure: Nominal pressure applied to the specific circuit by the pump(s).

3.4.2 holding circuit pressure: Maximum static pressure in a specific circuit limited by a relief valve at a flow no greater than 10 % of the rated circuit flow.

3.5 Limiting conditions (see also 7.1)

3.5.1 hydraulic limiting condition: Moment when the tool forces or lift capacity are limited by the working or holding circuit pressure.

3.5.2 engine stall limiting condition: Moment when the tool forces are limited by the engine stalling.

3.5.3 tipping limiting condition: Moment when the tool forces are limited by the onset of tipping of the machine.

3.5.4 slipping limiting condition: Moment when the tool forces are limited by the machine slipping on the test surface.

4 Apparatus

The apparatus shall comprise the items in 4.1 to 4.4.

4.1 Load cell or force transducer appropriate to the magnitude of the tool force to be measured and with an accuracy of ± 2 % inclusive of the readout device.

4.2 Hydraulic oil pressure gauge, with an accuracy of ± 2 %.

4.3 Wire ropes and shackles, pulley, safety chains and adjustable supporting frames.

4.4 Apparatus for measuring linear dimensions to an accuracy of $\pm 2\%$.

5 Test site

The test site shall consist of a substantially level, hard surface, preferably concrete, with anchor points and sufficient space to use load cells (4.1). Where measurements are to be made below the normal ground level, a pit shall be provided of sufficient depth to accept the tool and with enough room to accommodate the load cell, its anchorage and any auxiliary equipment.

NOTE — In the preferred method, the force to be measured is applied direct to the load cell (4.1). If the force is applied via a pulley, its friction should be taken into account in order to maintain the overall accuracy of $\pm 2\%$. As the mass of the rope itself may affect the accuracy, it is recommended that the rope should be as short as possible.

6 Preparation for test

The excavator shall be clean, and generally equipped as indicated in ISO 6016.

The machine shall be fitted with the bucket or other attachment and appropriate counterweights, and shall have the tyre pressure, and tyre ballast or track tension as specified by the manufacturer.

The working equipment for each test, using the various bucket pin, bucket link pin or arm pin positions, shall be as specified by the manufacturer (see figure 1).

Prior to testing, the engine and hydraulic system shall attain the normal working temperature, and the working and holding circuits pressures shall then be checked for compliance with the manufacturer's recommendations.

The machine shall be positioned on the test site (clause 5) and the appropriate bucket or attachment shall be suitably connected to a load cell (4.1) as illustrated in figures 1 to 5, the linkage position being dependent on which tool force is to be determined.

7 Methods of measuring tool forces

7.1 General

The test shall be conducted with the machine running in accordance with the manufacturer's operating instructions and observing all safety rules.

Safety chains (4.3) shall be fitted to prevent the machine from actually overturning in any test where the tipping limiting condition may occur.

With the engine running at the manufacturer's maximum recommended speed, the required cylinder(s) shall be operated independently and the force at the bucket lip or attachment recorded.

A series of preliminary trials shall be conducted with the equipment boom arm and bucket at different angles in relation to each other (i.e. by varying the cylinder stroke) to obtain the optimum position to give the maximum force.

The limiting conditions as defined in 3.5, shall be noted for each test (see 8.2).

In the case of the hydraulic limiting condition, the report should note the system or circuit in which the holding pressure was exceeded. If the tipping limiting condition is reached, the tool force shall be measured after the onset of tipping.

Safety chains shall be loose so that the machine can attain the tipping condition and yet be prevented from overturning.

If the slipping limiting condition is reached, the machine shall be anchored and the reported results should indicate that the maximum force was obtained by anchoring the machine.

When alternative pivot positions for the boom, dipper arm, attachment and cylinders and/or a telescopically adjustable boom are available, the relative pin positions of boom, dipper arm and bucket fixing and telescopic boom position as tested shall be recorded.

For excavators fitted with outriggers, the tests shall be conducted with the outriggers raised or lowered as specified by the manufacturer.

Each test shall be conducted three times, and the maximum tool force for each test shall be noted; the arithmetic mean of these three values shall be recorded in the test results.

The tool forces shall be measured in accordance with the above general requirements and the specific requirements given in 7.2, 7.3 and 7.4 and as illustrated in the appropriate figures.

7.2 Excavator fitted as hoe (see figures 1 and 2)

7.2.1 Maximum hoe tool force using bucket cylinder(s)

This is the maximum force at the bucket lip with the bucket cylinder(s) positioned to provide the maximum curling moment to the bucket around the bucket pivot. The bucket lip shall be moved towards the base machine. The force shall be measured tangential to the arc described by the bucket lip about the bucket pivot (see figure 1).

7.2.2 Maximum hoe tool force using arm cylinder(s)

This is the maximum force at the bucket lip with the arm cylinder positioned to provide the maximum moment to the arm around the arm pivot. The bucket lip shall be moved towards the base machine. The bucket shall be positioned as defined in 7.2.1, except that no part of the bucket shall be outside the arc described by the bucket lip about the arm pivot. The force shall be measured tangential to this arc (see figure 2).

7.3 Excavator fitted as shovel (see figures 3 and 4)

7.3.1 Maximum shovel tool force using bucket cylinder(s)

This is the maximum force at the bucket lip with the bucket cylinder positioned to provide the maximum curling moment to the bucket around the bucket pivot. The bucket lip shall be moved away from the base machine. The force shall be measured tangential to the arc described by the bucket lip about the bucket pivot (see figure 3).

7.3.2 Maximum shovel tool force using arm cylinder(s)

This is the maximum force at the bucket lip with the arm cylinder positioned to provide the maximum moment to the arm around the arm pivot. The bucket lip shall be moved away from the base machine. The bucket is to be positioned as defined in 7.3.1 except that no part of the bucket shall be outside the arc described by the bucket lip about the arm pivot. The force shall be measured tangential to this arc (see figure 4).

7.4 Excavator fitted with grab or clamshell attachment

7.4.1 Maximum grab or clamshell closing force

A load sensor is placed between the cutting edges of the clamshell, which is in the position of maximum closing force, applied by the hydraulic closing cylinders or other means. The distance between the cutting edges shall be recorded (see figure 5).

8 Test report

8.1 General information on machine

The information specified in 8.1.1 to 8.1.3 shall be reported.

8.1.1 Machine

- a) type;
- b) model;
- c) manufacturer;
- d) mass of machine as tested (in accordance with ISO 6016), in kilograms;
- e) working or holding circuit pressure setting(s), in kilopascals.

8.1.2 Type of undercarriage (i.e. crawler or wheeled machine, in accordance with ISO 6746-1)

a) Crawler machine:

- 1) type of track shoe,
- 2) maximum width (over tracks), $W1$, in metres,
- 3) track gauge, $W2$, in metres,
- 4) track shoe width, $W4$, in metres,
- 5) crawler base (distance between vertical centrelines of front and rear idlers or sprockets), $L2$, in metres;

b) Wheeled machine:

- 1) track, $W3$, in metres (specifying front and rear if different),
- 2) wheel base, $L3$, in metres,
- 3) tyre size(s),
- 4) tyre pressure, in kilopascals,
- 5) ballast (if specified), in kilograms.

8.1.3 Working equipment fitted

- a) boom length (at available pin or telescoped positions), in metres;
- b) arm length (at available pin or telescoped positions), in metres;
- c) bucket type, rated volume (in accordance with ISO 7451 or ISO 7546) and mass, in kilograms;
- d) attachments (specify) and mass, in kilograms;
- e) counterweights, in kilograms;
- f) outriggers: width between pad centres, outriggers extended, $W6$, in metres.

8.2 Reporting results

The tool forces shall be recorded in accordance with table 1.

Table 1 — Test results

Equipment fitted	Pin positions and arm length	Force N	Limiting conditions
Maximum hoe tool force using: — bucket cylinder — arm cylinder			
Maximum shovel tool force using: — bucket cylinder — arm cylinder			
Grab or clamshell: closing force	Distance between teeth/cutting edges		

https://standards.iteh.ai/catalog/standards/sist/171e8a21-aa62-4832-b93-1d899a1b59b/iso-6015-1989
 ISO 6015:1989
 iTeh STANDARD PREVIEW
 (standards.iteh.ai)

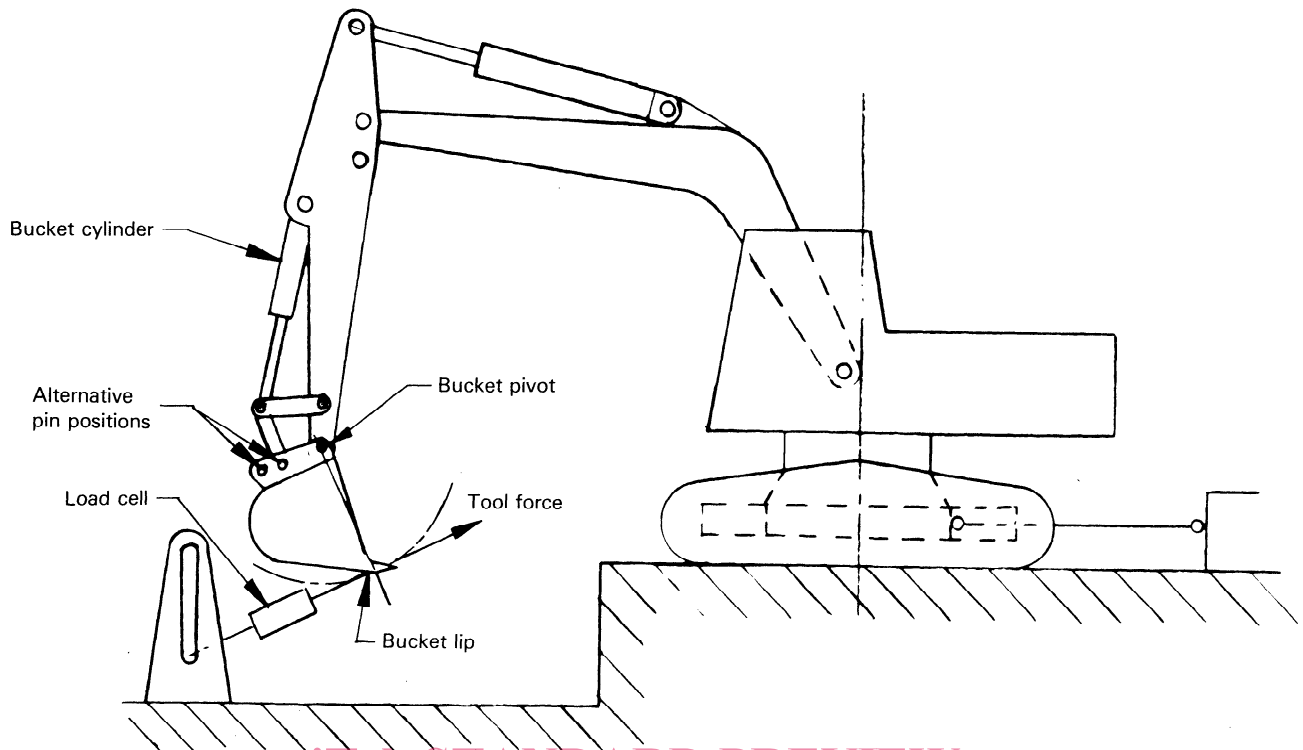

Figure 1 – Hydraulic excavator fitted with hoe – Typical arrangement for measuring maximum hoe tool force using bucket cylinder

ISO 6015:1989
<https://standards.iteh.ai/catalog/standards/sist/171e8a21-aa62-4832-bf93-1d8978a5b59b/iso-6015-1989>

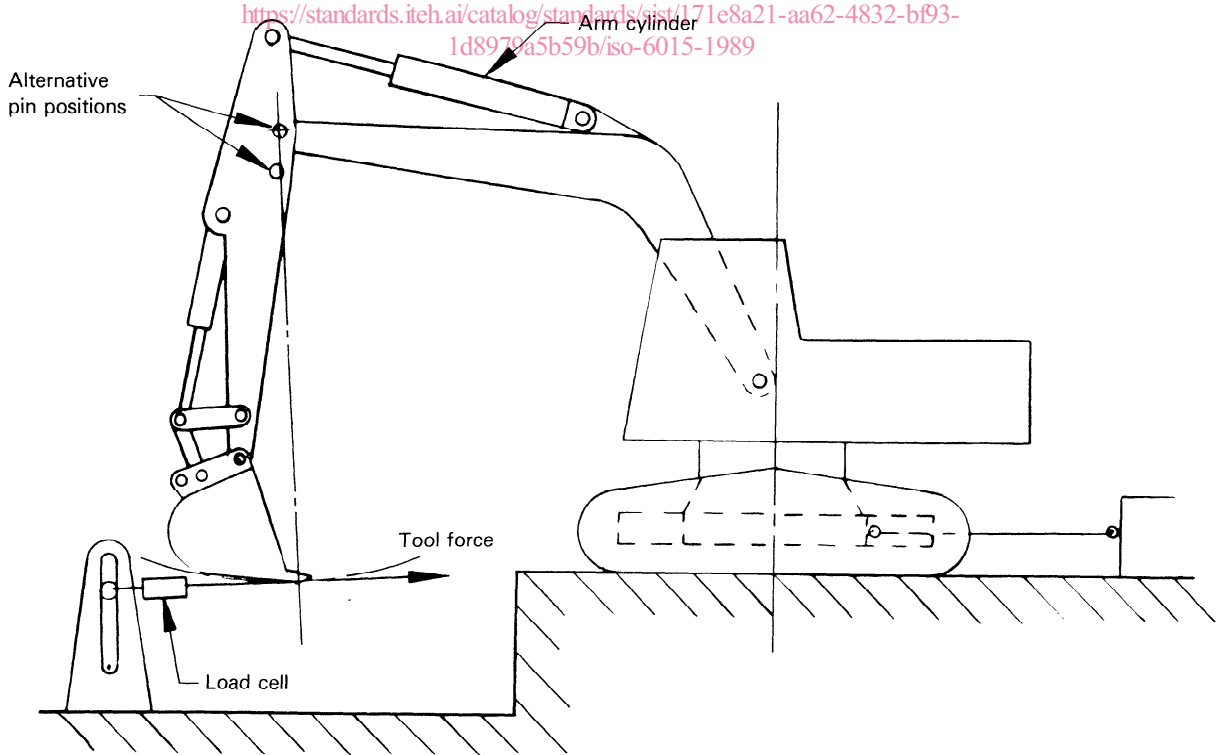

Figure 2 – Hydraulic excavator fitted with hoe – Typical arrangement for measuring maximum hoe tool force using arm cylinder

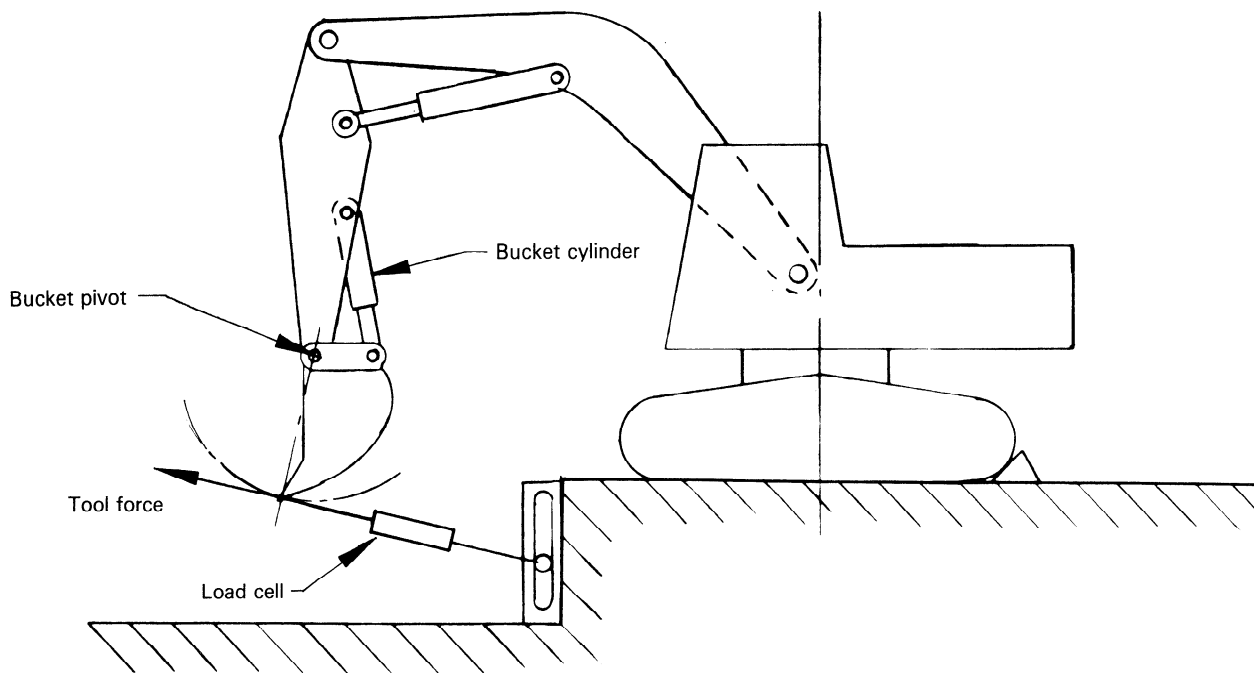

Figure 3 — Hydraulic excavator fitted with shovel — Typical arrangement for measuring maximum shovel tool force using bucket cylinder

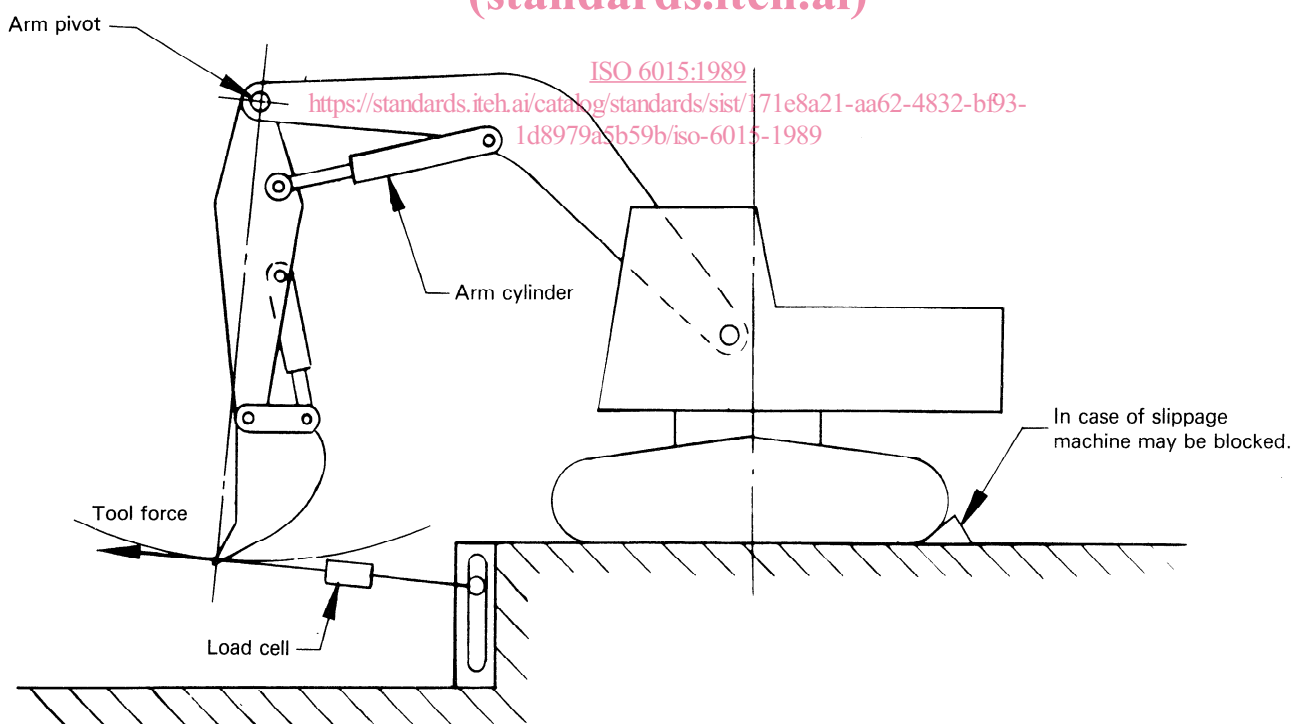
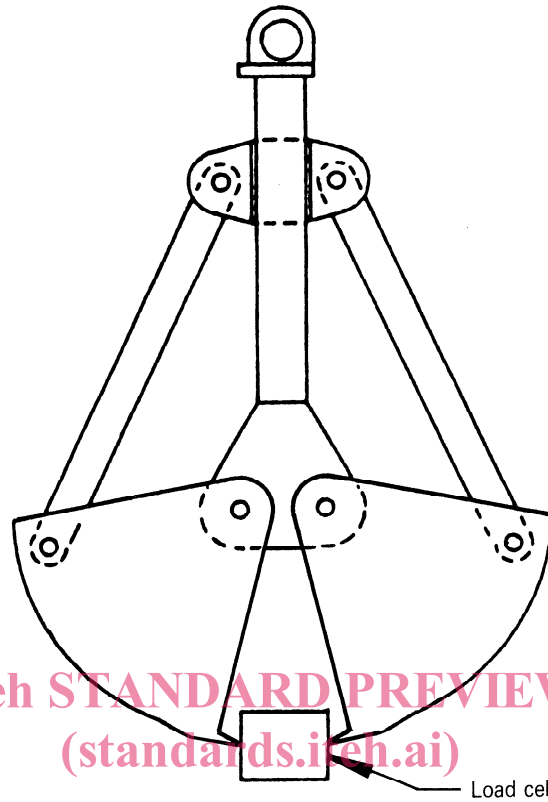

Figure 4 — Hydraulic excavator fitted with shovel — Typical arrangement for measuring maximum shovel tool force using arm cylinder



iTeh STANDARD PREVIEW
(standards.iteh.ai)

ISO 6015:1989

<https://standards.iteh.ai/catalog/standards/sist/171e8a21-aa62-4832-bf93-1d8979a5b59b/iso-6015-1989>

Figure 5 – Grab or clamshell – Typical test arrangement for determination of maximum closing force