

# INTERNATIONAL STANDARD

**ISO**  
**6020-2**

Second edition  
1991-09-15

---

---

**Hydraulic fluid power — Mounting dimensions  
for single rod cylinders, 16 MPa (160 bar)  
series —**

**Part 2:**  
**Compact series**

<https://standards.iteh.ai/standard/iso-6020-2/1991-09-15/iso-6020-2:1991>  
**ISO 6020-2:1991**  
**Transmissions hydrauliques — Dimensions d'interchangeabilité des  
vérins 16 MPa (160 bar) à simple tige —**  
**Partie 2: Série compacte**



Reference number  
ISO 6020-2:1991(E)

## Foreword

ISO (the International Organization for Standardization) is a worldwide federation of national standards bodies (ISO member bodies). The work of preparing International Standards is normally carried out through ISO technical committees. Each member body interested in a subject for which a technical committee has been established has the right to be represented on that committee. International organizations, governmental and non-governmental, in liaison with ISO, also take part in the work. ISO collaborates closely with the International Electrotechnical Commission (IEC) on all matters of electrotechnical standardization.

Draft International Standards adopted by the technical committees are circulated to the member bodies for voting. Publication as an International Standard requires approval by at least 75 % of the member bodies casting a vote.

International Standard ISO 6020-2 was prepared by Technical Committee ISO/TC 131, *Fluid power systems*, Sub-Committee SC 3, *Cylinders*.

This second edition cancels and replaces the first edition (ISO 6020-2:1981), which has been technically revised.

ISO 6020 consists of the following parts, under the general title *Hydraulic fluid power — Mounting dimensions for single rod cylinders, 16 MPa (160 bar) series*:

- Part 1: *Medium series*
- Part 2: *Compact series*
- Part 3: *Compact series, bores from 250 mm to 500 mm*

Annex A of this part of ISO 6020 is for information only.

© ISO 1991

All rights reserved. No part of this publication may be reproduced or utilized in any form or by any means, electronic or mechanical, including photocopying and microfilm, without permission in writing from the publisher.

International Organization for Standardization  
Case Postale 56 • CH-1211 Genève 20 • Switzerland

Printed in Switzerland

## Introduction

In hydraulic fluid power systems, power is transmitted and controlled through a liquid under pressure within an enclosed circuit.

One component of such systems is the fluid power cylinder. This is a device which converts power into linear mechanical force and motion. It consists of a movable element, i.e. a piston and piston rod, operating within a cylindrical bore.

## iTeh STANDARD PREVIEW (standards.iteh.ai)

[ISO 6020-2:1991](https://standards.iteh.ai/catalog/standards/sist/790b2f8b-a6e1-4ddf-b086-b10307e2d314/iso-6020-2-1991)

<https://standards.iteh.ai/catalog/standards/sist/790b2f8b-a6e1-4ddf-b086-b10307e2d314/iso-6020-2-1991>

**iTeh STANDARD PREVIEW**  
This page intentionally left blank  
**(standards.iteh.ai)**

ISO 6020-2:1991

<https://standards.iteh.ai/catalog/standards/sist/790b2f8b-a6e1-4ddf-b086-b10307e2d314/iso-6020-2-1991>

# Hydraulic fluid power — Mounting dimensions for single rod cylinders, 16 MPa (160 bar) series —

## Part 2: Compact series

### 1 Scope

This part of ISO 6020 establishes metric mounting dimensions for compact series cylinders, 16 MPa [160 bar<sup>1)</sup>], as required for interchangeability of commonly used hydraulic cylinders.

#### NOTES

1 This part of ISO 6020 allows manufacturers of hydraulic equipment flexibility in the design of metric cylinders and does not restrict technical development but does provide basic guidelines.

2 The compact series dimensions are most applicable to square head cylinders.

### 2 Normative references

The following standards contain provisions which, through reference in this text, constitute provisions of this part of ISO 6020. At the time of publication, the editions indicated were valid. All standards are subject to revision, and parties to agreements based on this part of ISO 6020 are encouraged to investigate the possibility of applying the most recent editions of the standards indicated below. Members of IEC and ISO maintain registers of currently valid International Standards.

ISO 273:1979, *Fasteners — Clearance holes for bolts and screws.*

ISO 3320:1987, *Fluid power systems and components — Cylinder bores and piston rod diameters — Metric series.*

ISO 4395:1978, *Fluid power systems and components — Cylinders — Piston rod thread dimensions and types.*

ISO 5598:1985, *Fluid power systems and components — Vocabulary.*

### 3 Definitions

For the purposes of this part of ISO 6020, the definitions given in ISO 5598 and the following definitions apply.

**3.1 cylinder:** Device which converts fluid power into linear mechanical force and motion.

**3.2 cylinder bore:** Internal diameter of the cylinder body.

**3.3 piston rod:** Element which transmits mechanical force and motion from the piston.

**3.4 mounting:** Device by which a cylinder is fastened to its mating element.

### 4 Dimensions

Mounting dimensions for cylinders manufactured in accordance with this part of ISO 6020 shall be selected from tables 1 to 13.

### 5 Bore sizes

The following bore sizes, in millimetres, are included in this compact series:

1) 1 bar = 0,1 MPa = 10<sup>5</sup> Pa; 1 MPa = 1 N/mm<sup>2</sup>

25 — 32 — 40 — 50 — 63 — 80 — 100 — 125 — 160 — 200

NOTE 3 Mounting dimensions for compact hydraulic single-rod cylinders with bores from 250 mm to 500 mm are specified in ISO 6020-3.

## 6 Mounting styles

This part of ISO 6020 includes the following mounting styles, in accordance with ISO 6099:

- ME5 — Head, rectangular (see figure 2 and table 2)
- ME6 — Cap, rectangular (see figure 3 and table 3)
- MP1 — Cap, fixed clevis (see figure 4 and table 4)
- MP3 — Cap, fixed eye (see figure 5 and table 5)
- MP5 — Cap, fixed eye with spherical plain bearing (see figure 6 and table 6)
- MS2 — Side lugs (see figure 7 and table 7)

- MT1 — Head, integral trunnion (male) (see figure 8 and table 8)
- MT2 — Cap, integral trunnion (male) (see figure 9 and table 9)
- MT4 — Intermediate fixed or movable trunnion (male) (see figure 10 and table 10)
- MX1 — Both ends studs or tie rods extended (see figure 11 and table 11)
- MX2 — Cap studs or tie rods extended (see figure 12 and table 12)
- MX3 — Head studs or tie rods extended (see figure 13 and table 13)

## 7 Piston rod characteristics

7.1 This part of ISO 6020 covers piston rods which have a shouldered male thread end (see figure 1 and table 1 for basic dimensions).

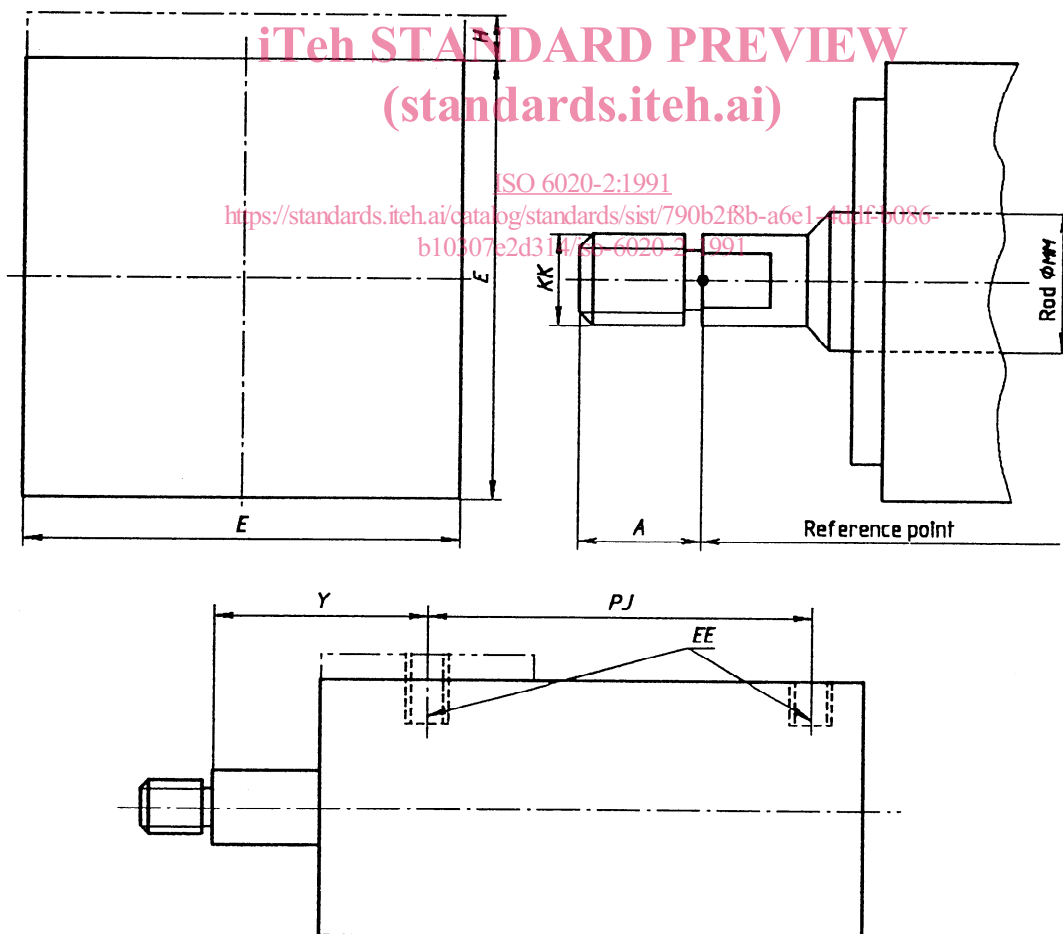

Figure 1 — General dimensions

Table 1 — General dimensions

Dimensions in millimetres

Bore	Rod MM	KK	A	H	E	Y	PJ	EE
25	12	M10 × 1,25	14	5	40	50	53	G 1/4
	18	M10 × 1,25 M14 × 1,5	14 18					
32	14	M12 × 1,25	16	5	45	60	56	G 1/4
	22	M12 × 1,25 M16 × 1,5	16 22					
40	18	M14 × 1,5	18	—	63	62	73	G 3/8
	28	M14 × 1,5 M20 × 1,5	18 28					
50	22	M16 × 1,5	22	—	75	67	74	G 1/2
	36	M16 × 1,5 M27 × 2	22 36					
63	28	M20 × 1,5	28	—	90	71	80	G 1/2
	45	M20 × 1,5 M33 × 2	28 45					
80	36	M27 × 2	36	—	115	77	93	G 3/4
	56	M27 × 2 M42 × 2	36 56					
100	45	M33 × 2	45	—	130	82	101	G 3/4
	70	M33 × 2 M48 × 2	45 63					
125	56	M42 × 2	56	—	165	96	117	G 1
	90	M42 × 2 M64 × 3	56 85					
160	70	M48 × 2	63	—	205	86	130	G 1
	110	M48 × 2 M80 × 3	63 95					
200	90	M64 × 3	85	—	245	98	165	G 1 1/4
	140	M64 × 3 M100 × 3	85 112					

NOTE — If other piston rod diameters or other piston rod threads are required, use those identified in ISO 3320 and ISO 4395.

7.2 For internally threaded rod ends, see ISO 4395.

7.3 For rod end eyes, International Standards are being prepared.

**8 Identification statement** (Reference to this part of ISO 6020)

Use the following statement in test reports, catalogues and sales literature when electing to comply with this part of ISO 6020:

"Interchangeable cylinder mounting dimensions selected in accordance with ISO 6020-2, *Hydraulic fluid power — Mounting dimensions for single rod cylinders, 16 MPa (160 bar) series — Part 2: Compact series.*"

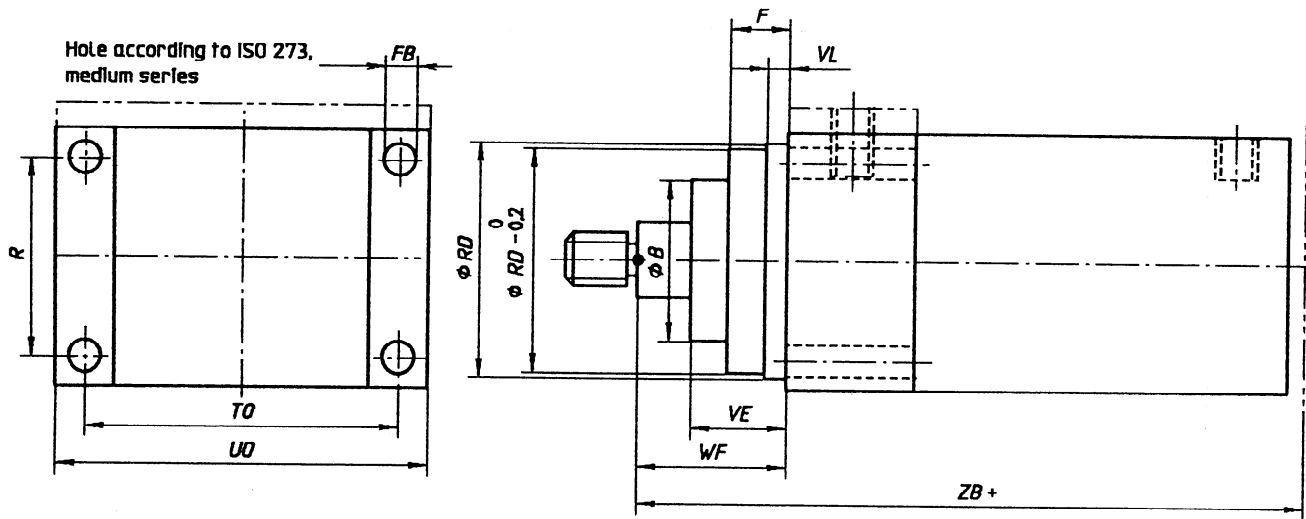

Figure 2 — ME5 — Head mounting, rectangular

Table 2 — Dimensions of head mountings, rectangular

Dimensions in millimetres

Bore	Rod MM	RD	TO	FB H13	R	WF	F	VE	VL	Dimensions in millimetres		
										B max.	UO max.	ZB max.
25	12	38	51	5,5	27	25	10	16	3	24	65	121
	18	38								30		
32	14	42	58	6,6	33	35	10	22	3	26	70	137
	22	42								34		
40	18	62	87	11	41	35	10	22	3	30	110	166
	28	62								42		
50	22	74	105	14	52	41	16	25	4	34	130	176
	36	74								50		
63	28	75	117	14	65	48	16	29	4	42	145	185
	45	88								60		
80	36	82	149	18	83	51	20	29	4	50	180	212
	56	105								72		
100	45	92	162	18	97	57	22	32	5	60	200	225
	70	125								88		
125	56	105	208	22	126	57	22	32	5	72	250	260
	90	150								108		
160	70	125	253	26	155	57	25	32	5	88	300	279
	110	170								133		
200	90	150	300	33	190	57	25	32	5	108	360	336
	140	210								163		



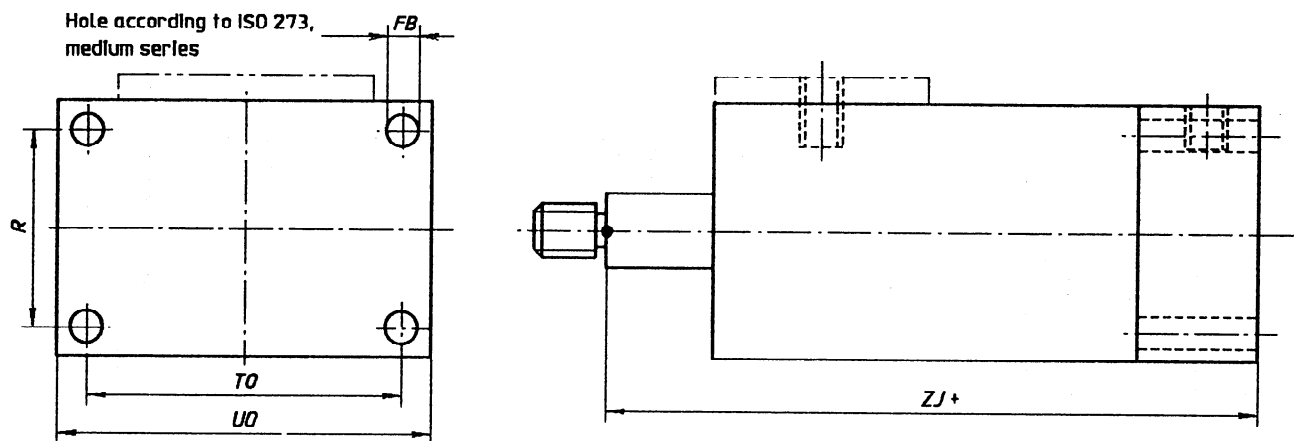

Figure 3 — ME6 — Cap mounting, rectangular

Table 3 — Dimensions of cap mountings, rectangular

Dimensions in millimetres

Bore	Rod MM	TO	FB H13	R	ZJ	UD max.
25	12	51	5,5	27	114	65
	18					
32	14	58	6,6	33	128	70
	22					
40	18	87	11	41	153	110
	28					
50	22	105	14	52	159	130
	36					
63	28	117	14	65	168	145
	45					
80	36	149	18	83	190	180
	56					
100	45	162	18	97	203	200
	70					
125	56	208	22	126	232	250
	90					
160	70	253	26	155	245	300
	110					
200	90	300	33	190	299	360
	140					

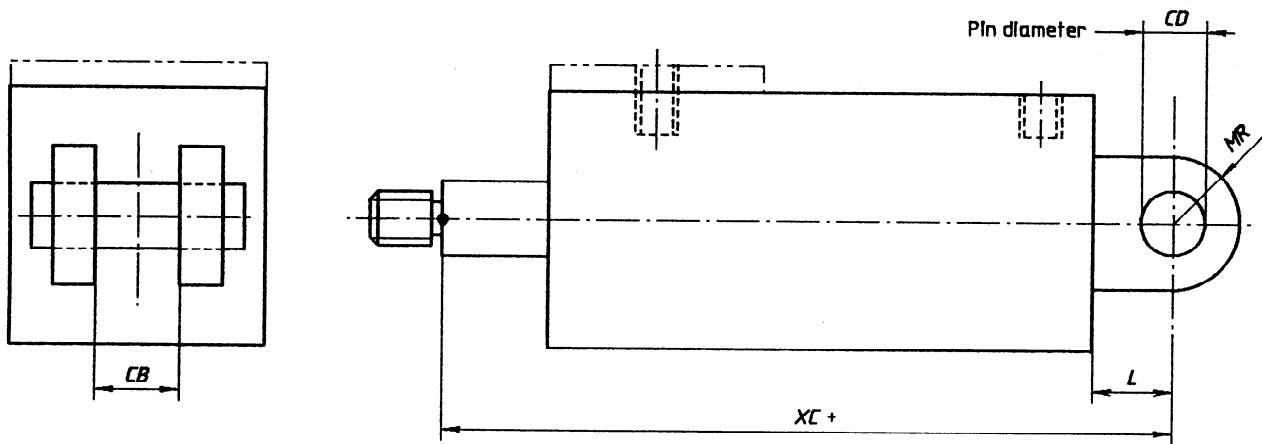

Figure 4 — MP1 — Cap mounting, fixed clevis

Table 4 — Dimensions of cap mountings, fixed clevis

Dimensions in millimetres

Bore	Rod MM	CB	CD	MR max.	L	XC
25	12	12	10	12	13	127
	18					
32	14	16	12	17	19	147
	22					
40	18	20	14	17	19	172
	28					
50	22	30	20	29	32	191
	36					
63	28	30	20	29	32	200
	45					
80	36	40	28	34	39	229
	56					
100	45	50	36	50	54	257
	70					
125	56	60	45	53	57	289
	90					
160	70	70	56	59	63	308
	110					
200	90	80	70	78	82	381
	140					

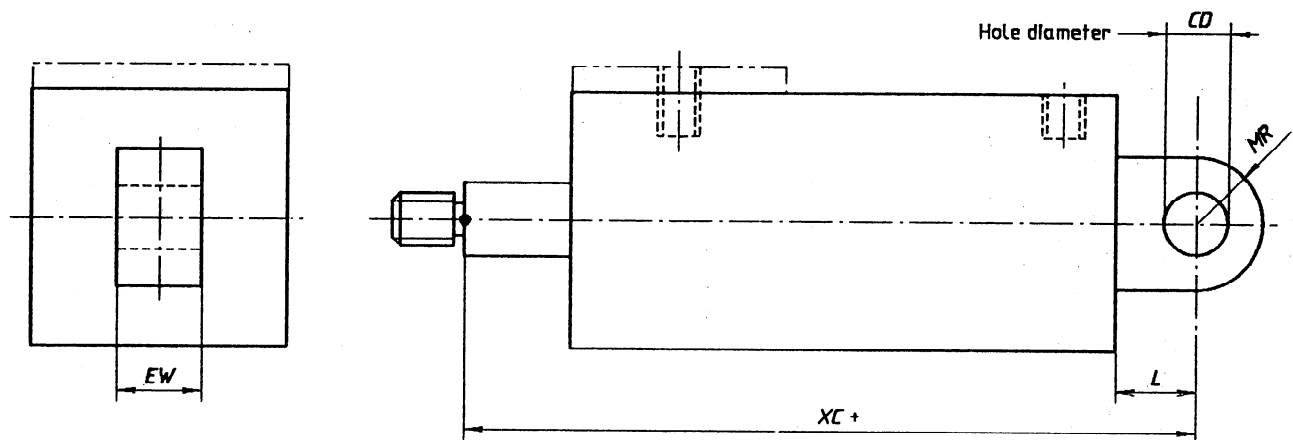

Figure 5 — MP3 — Cap mounting, fixed eye

Table 5 — Dimensions of cap mountings, fixed eye

Dimensions in millimetres

Bore	Rod MM	EW	CD	MR max.	L	XC
25	12	12	10	12	13	127
	18					
32	14	16	12	17	19	147
	22					
40	18	20	14	17	19	172
	28					
50	22	30	20	29	32	191
	36					
63	28	30	20	29	32	200
	45					
80	36	40	28	34	39	229
	56					
100	45	50	36	50	54	257
	70					
125	56	60	45	53	57	289
	90					
160	70	70	56	59	63	308
	110					
200	90	80	70	78	82	381
	140					