

---

# International Standard



# 6022

---

INTERNATIONAL ORGANIZATION FOR STANDARDIZATION • МЕЖДУНАРОДНАЯ ОРГАНИЗАЦИЯ ПО СТАНДАРТИЗАЦИИ • ORGANISATION INTERNATIONALE DE NORMALISATION

---

## Hydraulic fluid power — Single rod cylinders — Mounting dimensions — 250 bar (25 000 kPa) series

*Transmissions hydrauliques — Vérins 250 bar (25000 kPa) à simple tige — Dimensions d'interchangeabilité*

First edition — 1981-09-15

**ITeH STANDARD PREVIEW**  
**(standards.iteh.ai)**

[ISO 6022:1981](#)

<https://standards.iteh.ai/catalog/standards/sist/71c4b0a1-b205-48a9-815d-673506810af9/iso-6022-1981>

---

UDC 621.226

Ref. No. ISO 6022-1981 (E)

**Descriptors** : hydraulic fluid power, hydraulic equipment, hydraulic cylinders, dimensions, interchangeability, bores, fixing.

## Foreword

ISO (the International Organization for Standardization) is a worldwide federation of national standards institutes (ISO member bodies). The work of developing International Standards is carried out through ISO technical committees. Every member body interested in a subject for which a technical committee has been set up has the right to be represented on that committee. International organizations, governmental and non-governmental, in liaison with ISO, also take part in the work.

Draft International Standards adopted by the technical committees are circulated to the member bodies for approval before their acceptance as International Standards by the ISO Council.

International Standard ISO 6022 was developed by Technical Committee ISO/TC 131, *Fluid power systems and components*, and was circulated to the member bodies in November 1978.

ITeH STANDARD PREVIEW  
(standards.iteh.ai)

It has been approved by the member bodies of the following countries

Austria	Ireland	Spain
Belgium	Italy	Sweden
Chile	Japan	United Kingdom
Czechoslovakia	Korea, Rep. of	USA
Finland	Netherlands	USSR
France	Poland	Yugoslavia
Germany, F. R.	Romania	
India	South Africa, Rep. of	

The member bodies of the following countries expressed disapproval of the document on technical grounds :

Australia  
Hungary  
Norway

# Hydraulic fluid power — Single rod cylinders — Mounting dimensions — 250 bar (25 000 kPa<sup>1)</sup>) series

## 0 Introduction

In hydraulic fluid power systems, power is transmitted and controlled through a liquid under pressure within an enclosed circuit.

One component of such systems is the fluid power cylinder. This is a device which converts power into linear mechanical force and motion. It consists of a movable element, i.e. a piston and piston rod, operating within a cylindrical bore.

## 1 Scope and field of application

This International Standard establishes a metric series of mounting dimensions required for interchangeability of commonly used hydraulic cylinders.

NOTE — This International Standard allows manufacturers of hydraulic equipment freedom in the design of metric cylinders and does not restrict technical development but provides basic guidelines.

## 2 References

ISO 273, *Fasteners — Clearance holes for bolts and screws.*

ISO 3320, *Fluid power systems and components — Cylinder bores and piston rod diameters — Metric series.*

ISO 4395, *Fluid power systems and components — Cylinders — Piston rod thread dimensions and types.*

ISO 5598, *Fluid power systems and components — Vocabulary.*

## 3 Definitions

Definitions of other terms used in this International Standard are given in ISO 5598.

**3.1 cylinder** : A device which converts fluid power into linear mechanical force and motion.

**3.2 cylinder bore** : The internal diameter of the cylinder.

**3.3 piston rod** : The element transmitting mechanical force and motion from the piston.

**3.4 mounting** : A device by which a cylinder is fastened to its mating element.

## 4 Dimensions

Select mounting dimensions for cylinders manufactured in accordance with this International Standard from tables 1 to 4 inclusive.

## 5 Bore sizes

Included in this 250 bar series are the following bore sizes :

50 — 63 — 80 — 100 — 125 — 160 — 200 — 250 — 320 — 400 — 500 mm

## 6 Mounting styles

This International Standard includes the following mounting styles :

MF3 — Head circular flange mounting (see figure 2 and table 2)

MF4 — Cap circular flange mounting (see figure 2 and table 2)

MP3 — Cap fixed eye mounting (see figure 3 and table 3)

MP4 — Cap detachable eye mounting (see figure 3 and table 3)

MP5 — Cap fixed eye with spherical plain bearing mounting (see figure 3 and table 3)

MP6 — Cap detachable eye with spherical plain bearing mounting (see figure 3 and table 3)

MT4 — Intermediate fixed or movable trunnion (male) mounting (see figure 4 and table 4).

1) 1 kPa = 1 N/m<sup>2</sup>

**7 Piston rod characteristics**

**7.1** This International Standard covers piston rods having a shouldered male thread end (see figure 1 and table 1 for basic dimensions).

**7.2** For internally threaded rod ends, see ISO 4395.

**7.3** For rod end eyes, International Standards are being prepared.

**8 Identification statement** (Reference to this International Standard)

Use the following statement in test reports, catalogues and sales literature when electing to comply with this International Standard :

“Interchangeable cylinder mounting dimensions selected in accordance with ISO 6022, *Hydraulic fluid power — Single rod cylinders — Mounting dimensions — 250 bar (25 000 kPa) series*”.

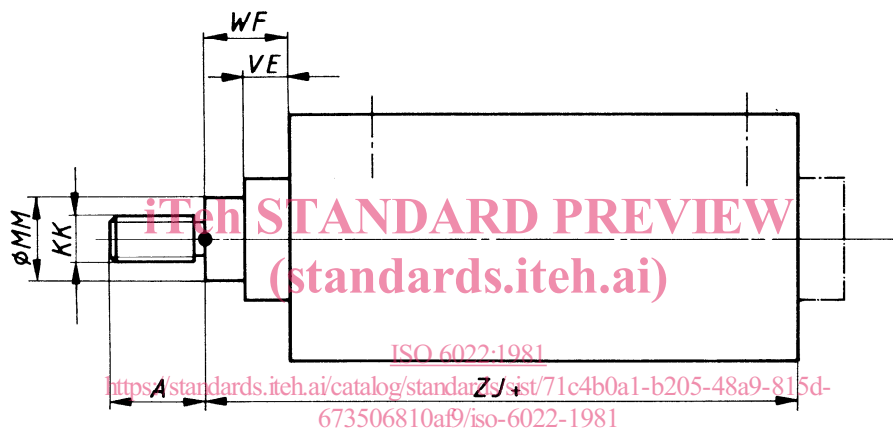

**Figure 1 — General dimensions**

**Table 1 — General dimensions**

Dimensions in millimetres

Bore	50	63	80	100	125	160	200	250	320	400	500
MM	32 to 36	40 to 45	50 to 56	63 to 70	80 to 90	100 to 110	125 to 140	160 to 180	200 to 220	250 to 280	320 to 360
ZJ	240	270	300	335	390	460	540	640	750	755	900
KK	M27 × 2	M33 × 2	M42 × 2	M48 × 2	M64 × 3	M80 × 3	M100 × 3	M125 × 4	M160 × 4	M200 × 4	M250 × 6
A	36	45	56	63	85	95	112	125	160	200	250
VE	29	32	36	41	45	50	61	71	88	110	135
WF	47	53	60	68	76	85	101	113	136	163	195

NOTE — If other piston rod diameters or other threads are required, use those identified in ISO 3320 and ISO 4395.

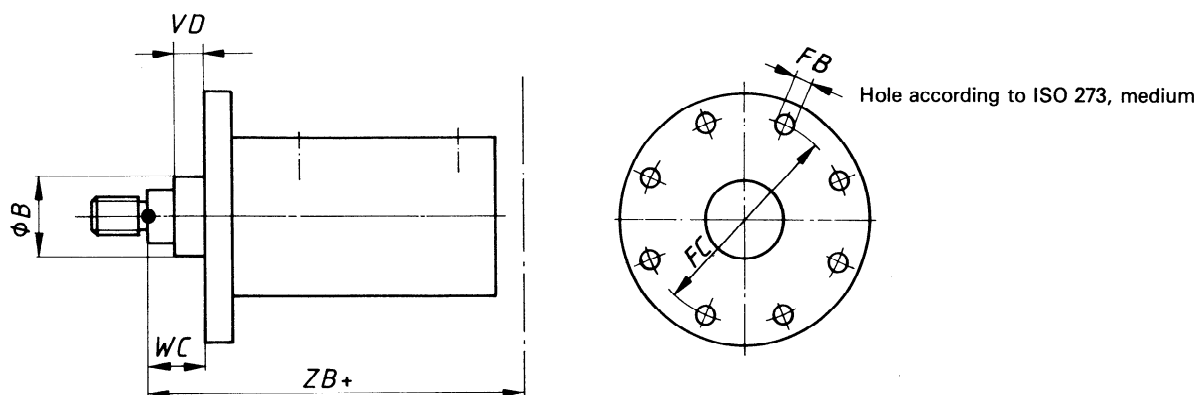

a) Head mounting

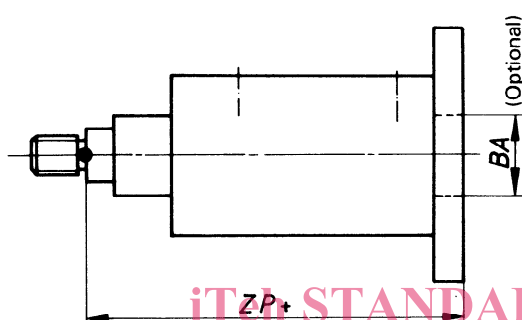

b) Cap mounting

Figure 2 — MF3 — Head circular flange mounting  
 MF4 — Cap circular flange mounting  
<https://standards.iteh.ai/standards.iteh.ai/673506810a19/iso-6022-1981>

Table 2 — Dimensions of mounting by circular flange

Dimensions in millimetres

Bore	50	63	80	100	125	160	200	250	320	400	500
FB	8 × φ 13,5	8 × φ 13,5	8 × φ 17,5	8 × φ 22	8 × φ 22	8 × φ 26	8 × φ 33	8 × φ 39	8 × φ 45	12 × φ 45	12 × φ 52
FC	132	150	180	212	250	315	385	475	600	720	840
VD min.	4	4	4	5	5	5	5	8	8	10	10
WC	22	25	28	32	36	40	45	50	56	63	70
ZP	265	298	332	371	430	505	596	703	830	855	1 025
ZB max.	244	274	305	340	396	467	550	652	764	775	932
B, BA	63	75	90	110	132	160	200	250	320	400	500

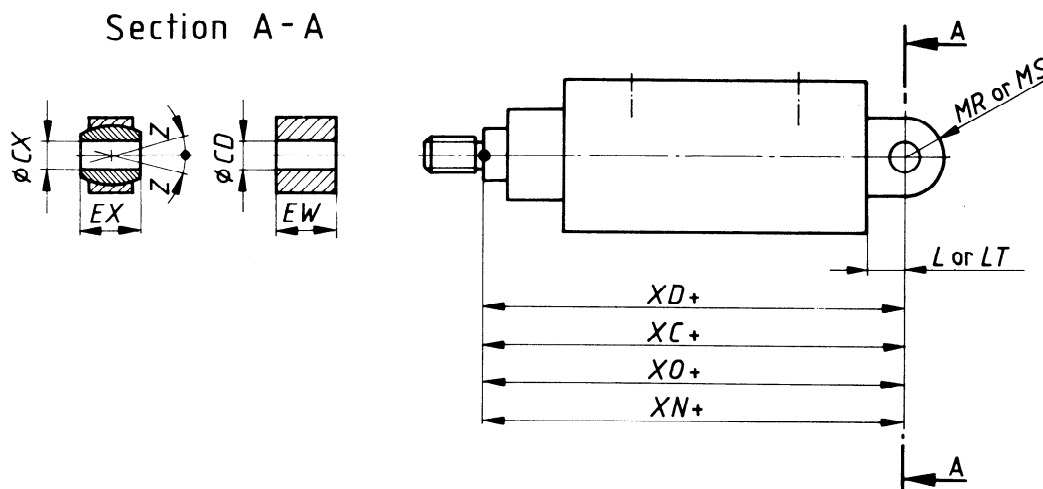

Figure 3 – MP3 – Cap fixed eye mounting  
 MP4 – Cap detachable eye mounting  
 MP5 – Cap fixed eye with spherical plain bearing mounting  
 MP6 – Cap detachable eye with spherical plain bearing mounting

iTeh STANDARD PREVIEW

Table 3 – Dimensions of mounting by cap eye  
 (standards.itih.ai)

Dimensions in millimetres

Bore	50	63	80	100	125	160	200	250	320	400	500
$CD^{1)}$ or $CX^{2)}$	32	40	50	63	80	100	125	160	200	250	320
$EW^{1)}$ or $EX^{2)}$	32	40	50	63	80	100	125	160	200	250	320
$L^{1)}$ or $LT^{2)}$ min.	40	50	63	71	90	112	160	200	250	320	375
$MR^{1)}$ or $MS^{2)}$ max.	40	50	63	71	90	112	160	200	250	320	375
$XC, XD,$ $XO$ or $XN^{3)}$	305	348	395	442	520	617	756	903	1 080	1 075	1 275
Tilting angle $Z$	4°										

1) The dimensions  $CD, EW, L$  and  $MR$  are valid for mounting types MP3 and MP4.

2) The dimensions  $CX, EX, LT$  and  $MS$  are valid for mounting types MP5 and MP6.

3) The dimension  $XC$  is valid for mounting type MP3, the dimension  $XD$  is valid for mounting type MP4, the dimension  $XO$  is valid for mounting type MP5 and the dimension  $XN$  is valid for mounting type MP6.

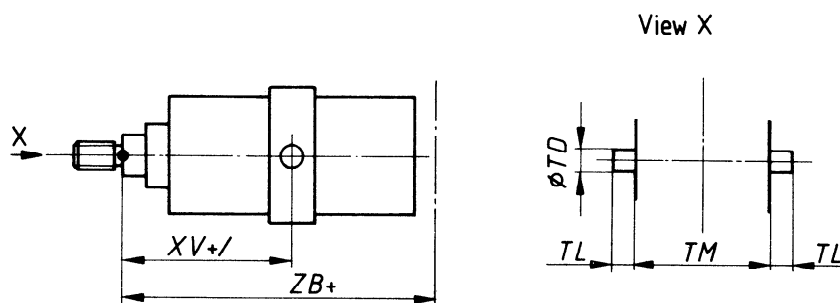

Figure 4 – MT4 – Intermediate fixed or movable trunnion (male)

Table 4 – Dimensions of mounting by central male trunnion

Dimensions in millimetres

Bore	50	63	80	100	125	160	200	250	320	400	500
TD f8	32	40	50	63	80	100	125	160	200	250	320
TL J16	25	32	40	50	63	80	100	125	160	200	250
TM h12	112	125	150	180	224	280	335	425	530	630	760
XV	(Variable)										
ZB max.	244	274	305	340	396	467	550	652	764	775	932

ISO 6022:1981  
<https://standards.iteh.ai/catalog/standards/sist/71c4b0a1-b205-48a9-815d-673506810af9/iso-6022-1981>

## Bibliography

The following document served as a reference in the preparation of this International Standard and will be helpful in the utilization of the standard :

ISO 4393, *Fluid power systems and components – Cylinders – Basic series of piston strokes.*

**iTeh STANDARD PREVIEW**  
**(standards.iteh.ai)**

This page intentionally left blank

ISO 6022:1981

<https://standards.iteh.ai/catalog/standards/sist/71c4b0a1-b205-48a9-815d-673506810af9/iso-6022-1981>