International Standard



6033

INTERNATIONAL ORGANIZATION FOR STANDARDIZATION • МЕЖДУНАРОДНАЯ ОРГАНИЗАЦИЯ ПО СТАНДАРТИЗАЦИИ • ORGANISATION INTERNATIONALE DE NORMALISATION

Cinematography — Projection reel size 7 for 8 mm Type S motion-picture film — Dimensions and specifications

Cinématographie — Bobine de projection, type 7, pour film cinématographique 8 mm type S — Dimensions et spécifications

First edition — 1983-12-15

ITeH STANDARD PREVIEW
(standards.iteh.ai)

[ISO 6033:1983](https://standards.iteh.ai/catalog/standards/sist/2b978481-a224-4993-ad12-7120519ddb1/iso-6033-1983)

<https://standards.iteh.ai/catalog/standards/sist/2b978481-a224-4993-ad12-7120519ddb1/iso-6033-1983>

UDC 778.533.4 : 771.531.352

Ref. No. ISO 6033-1983 (E)

Descriptors : cinematography, motion picture film, motion picture film 8 mm, reels, dimensions, specification.

Foreword

ISO (the International Organization for Standardization) is a worldwide federation of national standards bodies (ISO member bodies). The work of developing International Standards is carried out through ISO technical committees. Every member body interested in a subject for which a technical committee has been authorized has the right to be represented on that committee. International organizations, governmental and non-governmental, in liaison with ISO, also take part in the work.

Draft International Standards adopted by the technical committees are circulated to the member bodies for approval before their acceptance as International Standards by the ISO Council.

International Standard ISO 6033 was developed by Technical Committee ISO/TC 36, *Cinematography*, and was circulated to the member bodies in January 1982.

It has been approved by the member bodies of the following countries :

Austria	Egypt, Arab Rep. of	Mexico
Belgium	France	Spain
Canada	Germany, F. R.	Sweden
Czechoslovakia	Italy	USA
Denmark	Korea, Dem. P. Rep. of	USSR

[ISO 6033:1983](https://standards.iteh.ai/catalog/standards/sist/2b978481-a224-4993-ad12-7120519d0000/iso-6033-1983)

<https://standards.iteh.ai/catalog/standards/sist/2b978481-a224-4993-ad12-7120519d0000/iso-6033-1983>

The member body of the following country expressed disapproval of the document on technical grounds :

Japan

Cinematography — Projection reel size 7 for 8 mm Type S motion-picture film — Dimensions and specifications

1 Scope and field of application

1.1 This International Standard specifies the dimensions for 8 mm Type S motion-picture projection reels size 7, with a nominal film capacity of 15 m, generally used for returning the film from the processing laboratory and considered to be interchangeable in all models of 8 mm Type S projection cassettes (encapsulated devices), having an allowance for reels with up to 75 mm maximum outside flange diameter.

This type of reel also fits normal reel-to-reel projection equipment.

1.2 This International Standard supersedes the specification given for the No. 7 reel described in ISO 3639.

NOTE — The device specified in this International Standard is the same as the one identified as a spool in some countries. In others, a reel is used only with projectors, and spools having solid flanges are generally for raw stock used in cameras.

2 Reference

ISO 3653, *Cinematography — Spindles for 8 mm Type S motion-picture projection reels/spools — Dimensions*.

3 Dimensions

3.1 The dimensions shall be as shown in figure 1 and given in table 1.

3.2 The maximum radial run-out shall be as shown in figure 2.

3.3 The maximal lateral run-out, inward and outward, shall be as shown in figure 3 and given in table 2.

3.4 These dimensions apply regardless of the material (generally plastic) used for construction.

3.5 Film attachment shall be provided by a slot in the reel hub and a minimum cut-out in the hub is required for easy access to the film end. In order to secure the end of the film to the reel for automatic rewinding, and incorporated means of film retention, using a special retention plug or clip or other suitable means of film attachment is provided.

If a plug or clip is used, it shall not protrude beyond dimensions Q , R_4 , R_5 and W , R_6 , R_7 (striped areas in figure 1) respectively. For reel-to-reel operation, the retention means shall not protrude beyond dimensions $O + J + O$.

Once the retention means is pushed into its seat, it shall retain the film to such an extent that a minimum traction of 5 N, acting in a radial direction, will not tear off the reel hub a polyester film of 0,1 mm thickness.

3.6 The reel shall be designed with at least one solid flange (see figure 1), with the exception of the hub area. The solid flange side of the reel shall be opposite to the opening in the hub area for access to film attachment. By definition, the solid flange should not contain openings such as thread-up slots.

3.7 The attached rings, defined by dimensions F , G and O , are guiding means for horizontal operation of the reel.

3.8 Due to the fact that there are different thicknesses of film supports and magnetic striping, uniformity, as far as film thickness is concerned, no longer exists.

The capacity of the reel depends on the winding traction of the projector, the flatness of the film and the number and nature of existing splices.

For calculating the winding capacity of the reel, it is necessary to start with a compact winding. To take into account practice and more unfavourable conditions, a smaller winding diameter than the minimum diameter M of the reel flange is chosen.

The capacity K , in metres, is given by the following formula

$$K = \frac{\pi (d^2 - F_{\max}^2)}{4\,000\,t}$$

where

d is equal to M_{\min} minus 4, expressed in millimetres;

F_{\max} is the maximum hub diameter, expressed in millimetres;

t is the film thickness, expressed in millimetres.

4 Bibliography

ISO 1700, *Cinematography — 8 mm Type S motion-picture raw stock film — Cutting and perforating dimensions*.

ISO 3639, *Cinematography — Projection reels/spools 75 to 312 mm diameter for 8 mm Type S motion-picture film — Dimensions and specifications*.

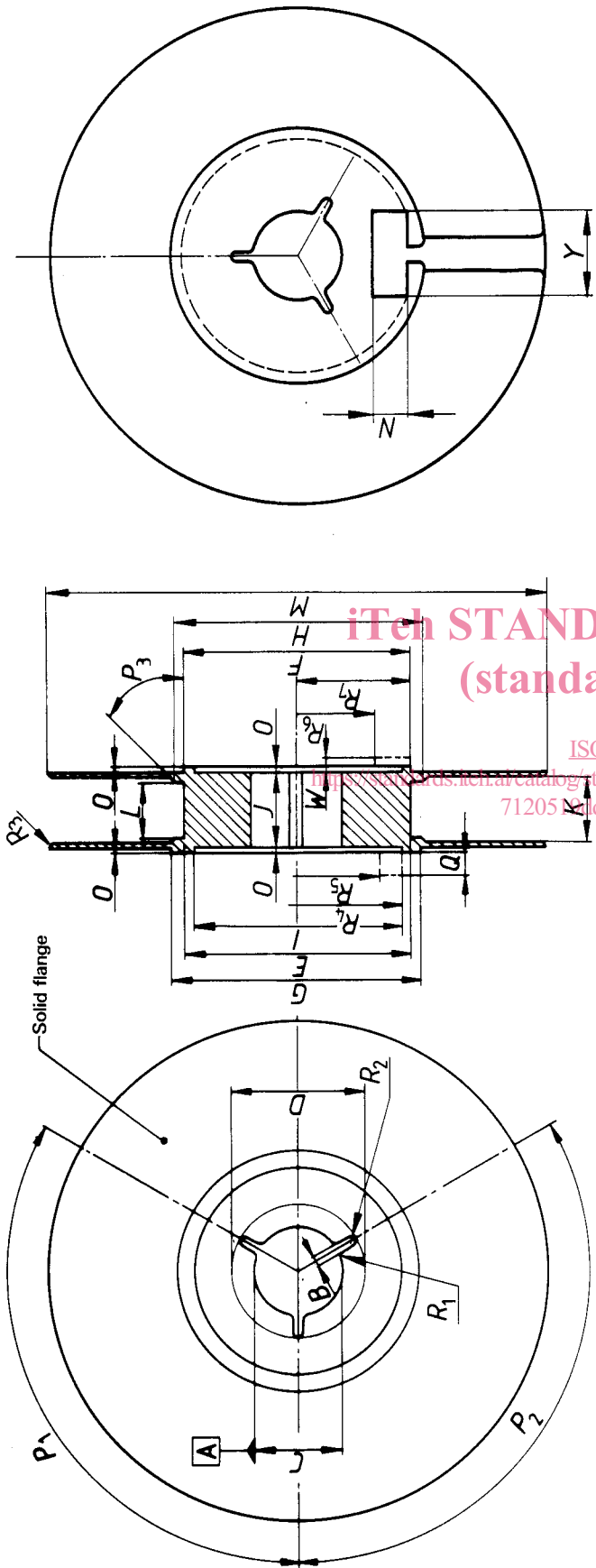

Figure 1 — Reel dimensions

STANDARD PREVIEW
(standards.iteh.ai)

ISO 6033-1983
https://standards.iteh.ai/catalog/standards/sls/2b973481-a224-4993-ad12-7120514dbd1/iso-6033-1983

Dimension	Millimetres	Inches
P ₁	120° ± 2°	120° ± 2°
P ₂	120° ± 2°	120° ± 2°
P ₃	45° ± 2°	45° ± 2°
N	6,1 min.	0.24 min.
Y	11,9 min.	0.47 min.

Dimension	Millimetres	Inches
L	8,4 +0,2 0	0.33 +0,01 0
M	74,9 0 -1	2.95 -0,04
O	0.51 +0,13 -0,25	0.020 +0,005 -0,010
Q	4,3 max.	0.17 max.
R ₁	0,9 max.	0.04 max.
R ₂	B/2 max.	B/2 max.
R _{3†}	0,5 max.	0.02 max.
R ₄	14,9 max.	0.59 max.
R ₅	11,25 min.	0.443 min.
R ₆	10,8 min.	0.43 min.
R ₇	16 max.	0.63 max.
W	0,8 max.	0.03 max.

Dimension	Millimetres	Inches
B	1,5 +0,3 0	0.06 +0,01 0
C	12,75 +0,15 0	0.502 +0,006 0
D	20,6 +0,5 0	0.81 +0,02 0
E	32,5 ± 0,5	1.28 ± 0.02
F	32,5 ± 0,5	1.28 ± 0.02
G	36,6 max.	1.44 max.
H	33,5 ± 0,5	1.32 ± 0.02
I	30,0 +0,5 0	1.18 +0,02 0
J	10,9 ± 0,3	0.43 ± 0.01
K*	8,4 min.	0.33 min.

* At the hub.

† If metal flanges are used, there should be no burr on the flange periphery.

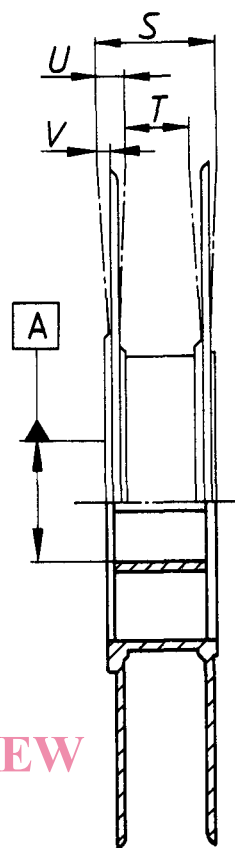
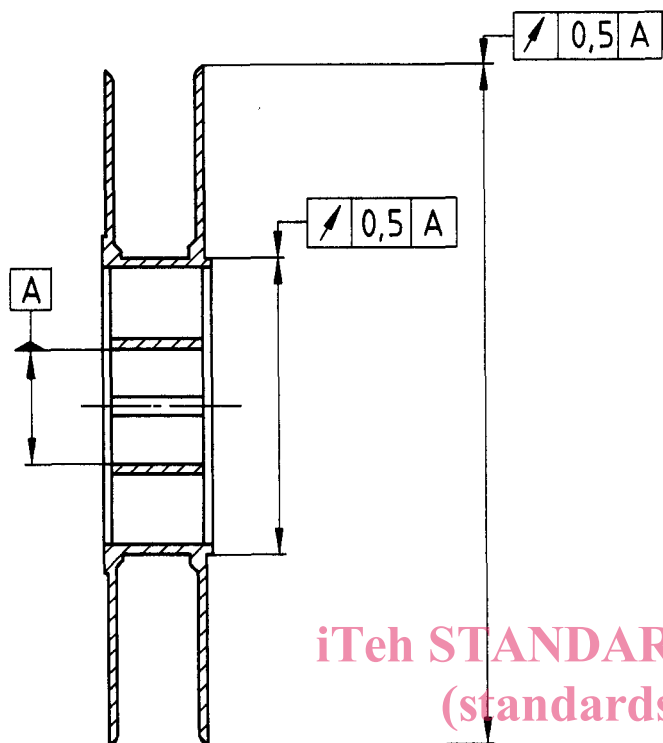

iTeh STANDARD PREVIEW
(standards.iteh.ai)

ISO 6033:1983

Figure 2 — Maximum radial runout

Figure 3 — Maximum lateral runout

<https://standards.iteh.ai/catalog/standards/sist/2b978481-224-4993-112-7120519ddb1/iso-6033-1983>

Table 2

Dimension	Millimetres	Inches
<i>S</i>	12,4 max.	0.49 max.
<i>T</i>	8,4 min.	0.33 min.
<i>U</i>	1,75 max.	0.069 max.
<i>V</i>	0,65 max.	0.025 max.

Table 3

Winding diameter : $d = 70$ mm *										
Maximum hub diameter : $F_{\max} = 33$ mm										
Total film thickness, t , mm **	0,09	0,10	0,11	0,12	0,13	0,14	0,15	0,16	0,17	0,18
Length of film permissible, K , m ***	33	30	27	25	23	21	20	19	18	17

* The value of d means a very tight coil of film; if the coil is rather loose, it results in a greater diameter d for the same capacity K .

** Inclusive of additional thickness due to magnetic track.

*** Capacity based on a tight coil, taking into account a core diameter on the upper limit of its tolerance.

Annex

Additional data

(This annex does not form part of the standard.)

- A.1** The values of figures 2 and 3 and table 2, concerning the radial and lateral run-out of the reel, are to be observed by the reel manufacturer.
- A.2** The functional values *S* and *T*, shown in figure 3 and given in table 2, shall apply for testing the reel.
- A.3** Manufacturers of projection equipment and/or projector cassettes should provide for the necessary free space (see figures 2 and 3 and table 2), allowing the reel to spin freely.
- A.4** The usual winding of film on the reel having a solid flange is such that the film perforations are closest to the flange with the threading slot (i.e. opposite the solid flange). The film is threaded clockwise on the reel with its emulsion layer outside.
- A.5** Three drive slots are specified for the spindle hole of each flange to facilitate easy loading of the reel on the drive spindle when used on reel-to-reel projection equipment, even though only one is normally used to drive the reel. When used in a projection cassette during projection, the reel generally spins freely; the drive slots are then used for the purpose of rewinding.
- A.6** The solid flange of the reel allows its operation by peripheral driving means.

iTeh STANDARD PREVIEW
(standards.iteh.ai)

ISO 6033:1983

<https://standards.iteh.ai/catalog/standards/sist/2b978481-a224-4993-ad12-7120519ddb1/iso-6033-1983>

iTeh STANDARD PREVIEW
(standards.iteh.ai)

ISO 6033:1983

<https://standards.iteh.ai/catalog/standards/sist/2b978481-a224-4993-ad12-7120519ddb1/iso-6033-1983>

iTeh STANDARD PREVIEW
(standards.iteh.ai)

ISO 6033:1983

<https://standards.iteh.ai/catalog/standards/sist/2b978481-a224-4993-ad12-7120519ddb1/iso-6033-1983>