**Steel — Hardenability test by end
quenching (Jominy test)**

Acier — Essai de trempabilité par trempe en bout (essai Jominy)

iTeh Standards
(<https://standards.itih.ai>)
Document Preview

[ISO 642:1999](#)

<https://standards.itih.ai/catalog/standards/iso/000f8cb4-e39f-4877-8319-9af561bb1893/iso-642-1999>



Contents	Page
1 Scope	1
2 Normative references	1
3 Principle.....	1
4 Symbols and designations	2
5 Form of test pieces and their preparation.....	2
6 Apparatus	3
7 Heating and quenching of test piece.....	6
8 Preparation for, and measurement of, hardness after quenching.....	6
9 Expression of results	7
10 Test report	8
Annex A (informative) Specification for the hardenability of a product	10
Annex B (informative) Additional information to clause 10.....	13
Annex C (informative) Calculation of the hardenability.....	15
Bibliography.....	16

[ISO 642:1999](https://standards.iteh.ai/standards/iso/000f8cb4-e39f-4877-8319-9af561bb1893/iso-642-1999)

<https://standards.iteh.ai/catalog/standards/iso/000f8cb4-e39f-4877-8319-9af561bb1893/iso-642-1999>

© ISO 1999

All rights reserved. Unless otherwise specified, no part of this publication may be reproduced or utilized in any form or by any means, electronic or mechanical, including photocopying and microfilm, without permission in writing from the publisher.

International Organization for Standardization
Case postale 56 • CH-1211 Genève 20 • Switzerland
Internet iso@iso.ch

Printed in Switzerland

Foreword

ISO (the International Organization for Standardization) is a worldwide federation of national standards bodies (ISO member bodies). The work of preparing International Standards is normally carried out through ISO technical committees. Each member body interested in a subject for which a technical committee has been established has the right to be represented on that committee. International organizations, governmental and non-governmental, in liaison with ISO, also take part in the work. ISO collaborates closely with the International Electrotechnical Commission (IEC) on all matters of electrotechnical standardization.

International Standards are drafted in accordance with the rules given in the ISO/IEC Directives, Part 3.

Draft International Standards adopted by the technical committees are circulated to the member bodies for voting. Publication as an International Standard requires approval by at least 75 % of the member bodies casting a vote.

International Standard ISO 642 was prepared by Technical Committee ISO /TC 17 *Steel*, Subcommittee SC 7, *Methods of testing (other than mechanical tests and chemical analysis)*.

This second edition cancels and replaces the first edition (ISO 642:1979) which has been technically revised.

Annexes A, B, and C of this International Standard are for information only.

iTeh Standards
(<https://standards.itih.ai>)
Document Preview

[ISO 642:1999](https://standards.itih.ai/catalog/standards/iso/000f8cb4-e39f-4877-8319-9af561bb1893/iso-642-1999)

<https://standards.itih.ai/catalog/standards/iso/000f8cb4-e39f-4877-8319-9af561bb1893/iso-642-1999>

Steel — Hardenability test by end quenching (Jominy test)

1 Scope

This International Standard specifies a method for determining the hardenability of steel by end quenching (Jominy test) by using a test piece 25 mm in diameter and 100 mm long.

NOTE By agreement and for a defined field of application, the test described in this International Standard may be replaced by the calculation of the Jominy curve in accordance with an accepted mathematical model (see annex C). In case of dispute, the test shall be carried out.

2 Normative references

The following normative documents contain provisions which, through reference in this text, constitute provisions of this International Standard. For dated references, subsequent amendments to, or revisions of, any of these publications do not apply. However, parties to agreements based on this International Standard are encouraged to investigate the possibility of applying the most recent editions of the normative documents indicated below. For undated references, the latest edition of the normative document referred to applies. Members of ISO and IEC maintain registers of currently valid International Standards.

ISO 6507-1, *Metallic materials — Vickers hardness test — Part 1: Test method*.

ISO 6508-1, *Metallic materials — Rockwell hardness test — Part 1: Test method (scales A, B, C, D, E, F, G, H, K, N, T)*.

ISO 6508-2, *Metallic materials — Rockwell hardness test) — Part 2: Verification and calibration of testing machines (scales A, B, C, D, E, F, G, H, K, N, T)*.

ISO 6508-3, *Metallic materials — Rockwell hardness test — Part 3: Calibration of reference blocks (scales A, B, C, D, E, F, G, H, K, N, T)*.

3 Principle

The test consists of:

- a) heating a cylindrical test piece to a specified temperature in the austenitic range for a specified period of time;
- b) quenching it by spraying water on one of its ends under specified conditions;
- c) measuring the hardness at certain given points, on longitudinal flats made on the test piece, in order to determine the hardenability of the steel by variations of this hardness.

4 Symbols and designations

Symbol	Designation	Value
L	Total length of test piece	$(100 \pm 0,5)$ mm
D	Diameter of test piece	$(25^{+0,5}_0)$ mm
t	Time during which test piece is maintained at heating temperature	(30^{+5}_0) min
t_m	Maximum time lag between removal of test piece from furnace and start of quenching	5 s
T	Temperature of cooling water	(20 ± 5) °C
a	Internal diameter of vertical water supply pipe	$(12,5 \pm 0,5)$ mm
h	Height of water jet without test piece in position	(65 ± 10) mm
l	Distance from end of water supply pipe to lower end of test piece	$(12,5 \pm 0,5)$ mm
e	Depth of flats for measurement of hardness	$(0,4 \text{ to } 0,5)$ mm
d	Distance, in millimetres, from quenched end to points where hardness is measured	
J_{xx-d}	Jominy hardenability index at distance d , in Rockwell HRC-mm	
JHV_{xx-d}	Jominy hardenability index at distance d , in Vickers HV 30-mm	

5 Form of test pieces and their preparation

5.1 Sampling

ISO 642:1999

<https://standards.iteh.ai/catalog/standards/iso/00018cb4-e39f-4877-8319-9af561bb1893/iso-642-1999>

In the absence of specific requirements in the product standard, and unless otherwise agreed on the order and regardless of the thickness (or diameter) of the product, the sampling of test piece from the product can be made:

- either by hot rolling or forging of test piece with 30 mm to 32 mm diameter;
- or by machining of test piece with diameter $(25^{+0,5}_0)$ mm whose axis shall be at least at (20^{+5}_0) mm from the surface product (see Figure 1).

In case of products from continuous casting, a minimum reduction ratio 8:1 is recommended before sampling.

In all the forming processes preceding the machining of the test piece, the deformation of the product from all sides should be as uniform as possible.

In the case of a separately cast reference test piece, the original cross section before deformation must be at least three times that corresponding to the required diameter of 30 mm to 32 mm.

By special agreement, the test piece can be obtained by a suitable casting process and tested in the as-cast condition.

The flats of the test piece shall have their axes at approximately the same distance from the product surface (see Figure 1). For this purpose, the test piece shall be marked so that its position in the round bar can be clearly recognized.

5.2 Dimensions

5.2.1 The test piece shall consist of a round bar machined to a diameter of 25 mm and a length of 100 mm.

5.2.2 The end of the test piece which will not be quenched shall be 30 mm to 32 mm or 25 mm in diameter, depending upon the form of that end. Two examples, test pieces with a flange or an undercut (to permit rapid centring and fitting in position for the quenching operation by means of an appropriate support) are shown in Figure 2.

5.2.3 The test piece shall, if necessary, be marked (on the end opposite to the end to be quenched) to enable its position to be identified in relation to the original product.

5.3 Heat treatment

Unless otherwise agreed, the test piece shall be normalized before machining and quenching. The normalizing process shall be carried out at the average temperature within the range specified in the material standard. If the material standard does not specify a temperature for normalizing, the normalizing temperature shall be subject to special agreement or duly selected by the testing department. The holding time at normalizing temperature shall be $(30 \begin{smallmatrix} +5 \\ 0 \end{smallmatrix})$ min.

The heat treatment shall be carried out in each case in such a way that the finish-machined test piece shows absolutely no traces of decarburization.

5.4 Machining

The cylindrical surface of the test piece shall be machined by fine turning; the surface of the test piece end to be quenched shall have a reasonably fine finish, preferably obtained by fine grinding, and should be free from burrs (see Figure 2).

6 Apparatus

The apparatus consists of a device for quenching the test piece.

6.1 The quenching device consists essentially of a means of suddenly inducing the water jet to impinge on the end of the test piece to be quenched. This can be realized e.g., by a quick action tap and a system to adjust the flow rate of the water or a disc allowing the water jet to be released and cut off rapidly (see Figure 3). In the case of a quick action tap the length of the water supply pipe behind the tap shall be at least 50 mm in order to ensure non-turbulent water flow.

6.2 The relative positions of the end of the water supply pipe and the test piece support shall be such that the distance between the end of the water supply pipe and the test piece end to be quenched is $(12,5 \pm 0,5)$ mm (see Figure 3).

6.3 The test piece support shall allow precise centring of the test piece above the end of the water supply pipe and the holding of it in position during spraying. It shall be dry while the test piece is being placed in position; the test piece shall be protected from water splashes while it is being placed in position as well as before and during the actual end quenching operation.

6.4 The height of the water jet above the end of the water supply pipe without the test piece in position shall be (65 ± 10) mm (see Figure 4).

The water temperature in the pipe shall be (20 ± 5) °C.

In the case of comparative tests, tests shall be carried out with the same water temperature.

6.5 The test piece shall be protected from draughts throughout the heating and quenching.

Dimensions in millimetres

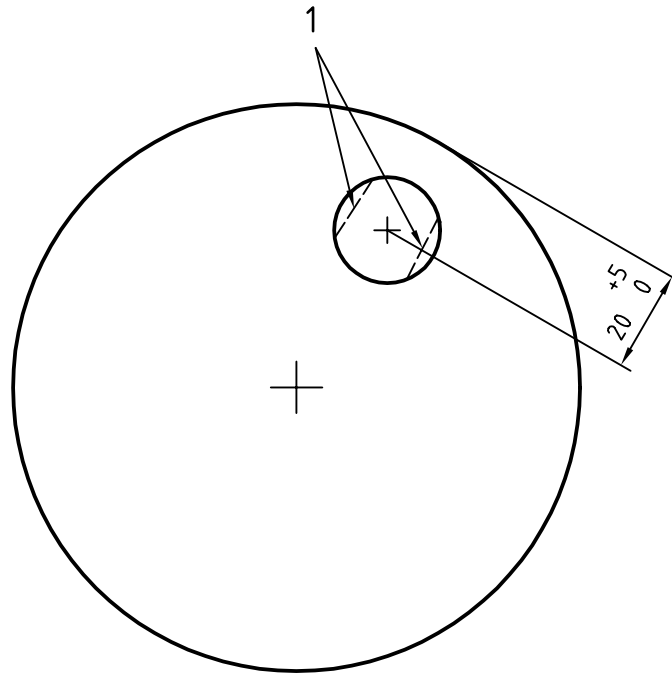

Key

- 1 Test flats.

Figure 1 — Sampling by machining of the test piece

Dimensions in millimetres

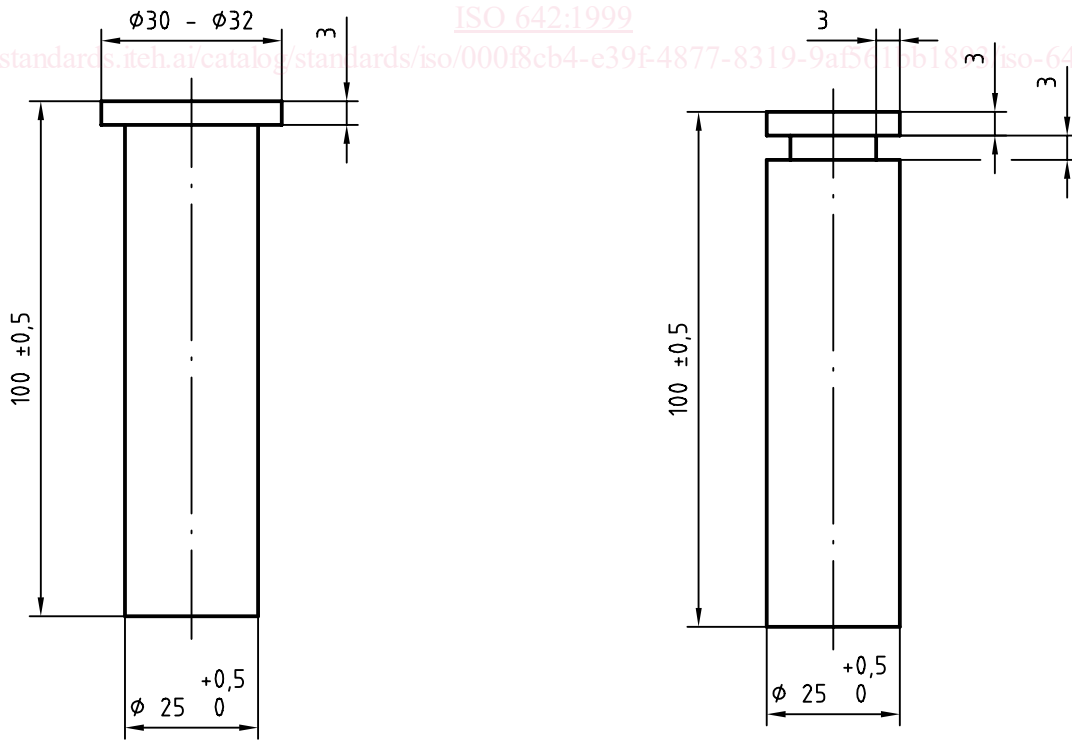

a) test piece with flange

b) test piece with undercut

Figure 2 — Dimensions of test piece

Dimensions in millimetres

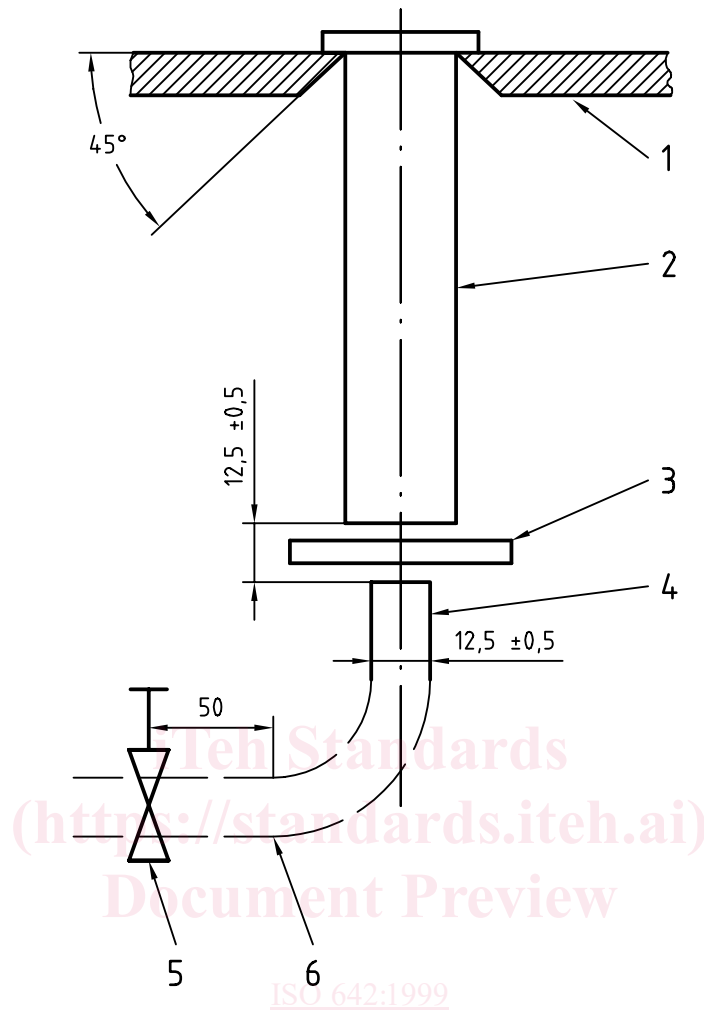
**Key**

- | | |
|--|-----------------------------|
| 1 Device for fixing and centring the test piece. | 4 End of water supply pipe. |
| 2 Test piece in position. | 5 Quick-action tap. |
| 3 Disc. | 6 Water supply pipe. |

Figure 3 — Diagram of quenching device

Dimensions in millimetres

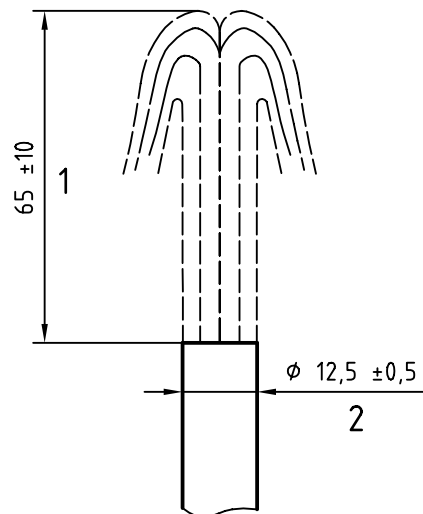
**Key**

- 1 Height of free water jet.
- 2 Diameter of end of water supply pipe.

Figure 4 — End of water supply pipe**7 Heating and quenching of test piece****7.1 Heating**

7.1.1 The test piece shall be heated uniformly to the temperature specified in the relevant product standard or fixed by special agreement for at least 20 min and then maintained for (30^{+5}_0) min at the agreed-upon temperature. For particular types of furnace, this period can be determined as a result of previous experience establishing the minimum time necessary for the centre of the test piece to reach the desired temperature (this temperature can be verified by means of, e.g., a thermocouple placed in a hole drilled along the axis of the test piece at the head end).

7.1.2 Precautions shall be taken to minimize decarburization or carburization of the test piece, and to avoid any marked oxidation with formation of scale.

7.2 Quenching

7.2.1 The time between removal of the test piece from the furnace and the commencement of spraying shall not exceed 5 s.

During its removal from the furnace and positioning in the holder, the test piece shall only be held with the tongs at the end which is not to be quenched either on the flange side or the undercut side.

7.2.2 The time of spraying shall be at least 10 min. After this time, the cooling of the test piece can be completed by immersing it in cold water.

8 Preparation for, and measurement of, hardness after quenching

8.1 Two flats for measuring the hardness shall be ground on the surface 180° apart and parallel to the axis of the test piece. In the case of test pieces prepared by machining, the two flats shall be at the same distance from the product surface (see Figure 1). They shall be from 0,4 mm to 0,5 mm deep. These flats shall be machined using an