



SLOVENSKI STANDARD SIST ISO 6099:1998

01-december-1998

Fluid power systems and components -- Cylinders -- Identification code for mounting dimensions and mounting types

Fluid power systems and components -- Cylinders -- Identification code for mounting dimensions and mounting types

Transmissions hydrauliques et pneumatiques -- Vérins -- Code d'identification des dimensions de montage et des modes de fixation

iteh STANDARD PREVIEW
(standards.iteh.ai)

Ta slovenski standard je istoveten z: **ISO 6099:1985**
<https://standards.iteh.ai/catalog/standards/sist/62707159-87f2-4212-9987-3ec8413f2f07/sist-iso-6099-1998>

ICS:

23.100.20 Pomoč pri delu Cylinders

SIST ISO 6099:1998 en

iTeh STANDARD PREVIEW
(standards.iteh.ai)

SIST ISO 6099:1998

<https://standards.iteh.ai/catalog/standards/sist/82707139-b7f2-4212-9987-3ec8413f2f07/sist-iso-6099-1998>

International Standard



6099

INTERNATIONAL ORGANIZATION FOR STANDARDIZATION • МЕЖДУНАРОДНАЯ ОРГАНИЗАЦИЯ ПО СТАНДАРТИЗАЦИИ • ORGANISATION INTERNATIONALE DE NORMALISATION

Fluid power systems and components — Cylinders — Identification code for mounting dimensions and mounting types

Transmissions hydrauliques et pneumatiques — Vérins — Code d'identification des dimensions de montage et des modes de fixation

iTeh STANDARD PREVIEW

Second edition — 1985-09-15 (standards.iteh.ai)

[SIST ISO 6099:1998](#)

<https://standards.iteh.ai/catalog/standards/sist/82707139-b7f2-4212-9987-3ec8413f2f07/sist-iso-6099-1998>

UDC 621.226

Ref. No. ISO 6099-1985 (E)

Descriptors : hydraulic fluid power, pneumatic fluid power, hydraulic equipment, pneumatic equipment, hydraulic cylinders, pneumatic cylinders, dimensioning, designation.

Foreword

ISO (the International Organization for Standardization) is a worldwide federation of national standards bodies (ISO member bodies). The work of preparing International Standards is normally carried out through ISO technical committees. Each member body interested in a subject for which a technical committee has been established has the right to be represented on that committee. International organizations, governmental and non-governmental, in liaison with ISO, also take part in the work.

Draft International Standards adopted by the technical committees are circulated to the member bodies for approval before their acceptance as International Standards by the ISO Council. They are approved in accordance with ISO procedures requiring at least 75 % approval by the member bodies voting.

International Standard ISO 6099 was prepared by Technical Committee ISO/TC 131, *Fluid power systems*.

ISO 6099 was first published in 1982. This second edition cancels and replaces the first edition; the following technical changes have been made to the previous edition:

- the definition for letter code *A* has been revised;
- definitions for the letter codes *AA* and *AM* have been added;
- figure 2 and figures 47 to 56 have been revised to take account of the new letter codes *AA* and *AM*;
- mounting types MF 8 (figure 24) and MS 3 (figure 39) have been added;
- because of the new mounting types, clauses 6.2 and 8 have been completed, and the numbering of figures from figure 24 has been changed accordingly.

Contents

	Page
0 Introduction	1
1 Scope and field of application	1
2 Reference	1
3 Definitions	1
4 Reference point	2
5 Letter codes for identifying cylinder mounting, envelope and accessory dimensions	2
6 Identification code for mounting types	5
7 Letter codes of mounting and envelope dimensions according to cylinder mounting types	6
8 Listing for letter codes	22
9 Identification statement	45

iTeh STANDARD PREVIEW
(standards.iteh.ai)

<https://standards.iteh.ai/catalog/standards/sist/82707139-b7f2-4212-9987-3ec841312f07/sist-iso-6099-1998>

iTeh STANDARD PREVIEW
(standards.iteh.ai)

This page intentionally left blank

SIST ISO 6099:1998

<https://standards.iteh.ai/catalog/standards/sist/82707139-b7f2-4212-9987-3ec8413f2f07/sist-iso-6099-1998>

Fluid power systems and components — Cylinders — Identification code for mounting dimensions and mounting types

iTeh STANDARD PREVIEW (standards.iteh.ai)

0 Introduction

In fluid power systems, power is transmitted and controlled through a fluid (liquid or gas) under pressure within an enclosed circuit. Systems and components are generally designed and marketed for a specific fluid pressure.

One component of such systems is the fluid power cylinder. This is a device which converts power into linear mechanical force and motion. It consists of a movable element, i.e. a piston and piston rod, operating within a cylindrical bore.

1 Scope and field of application

This International Standard specifies a conventional system for identifying fluid power cylinder dimensions and mounting dimensions thereof. Such a system will be composed of

- a) a letter code for identifying
 - mounting dimensions
 - envelope dimensions
 - cylinder fitting dimensions;
- b) a code for identifying cylinder mounting types.

This International Standard does not represent a standard list of all cylinder mounting types.

The codes indicated in this International Standard are also not to be considered as complete for the development of future interchangeability standards. It establishes uniform descriptions for dimensions and achieves a conformity of language.

Although this International Standard presents a code and a method of dimensioning, it is not intended that all dimensions shall be standardized.

The same codes can be used for analogous dimensions when this involves neither confusion nor misunderstanding.

2 Reference

ISO 5598, *Fluid power systems and components — Vocabulary.*

3 Definitions

For definitions of terms used in this International Standard, see ISO 5598.

ISO 6099-1985 (E)

4 Reference point

Axial dimensions are determined from a reference point which is the same for all cylinders, whatever their mounting method. It is the theoretical point of force transfer from the piston rod to the movable element [theoretical reference point (TRP)].

4.1 For a plain rod end, the reference point is located on the rod centreline at the end of the piston rod :

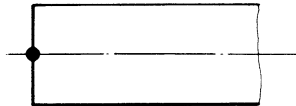

4.2 For a pin rod end, the reference point is located at the intersection of the pin centreline and of the piston rod centreline :

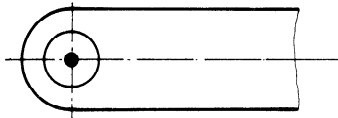

4.3 For a female threaded rod end, the reference point is located on the rod centreline at the end of the piston rod :

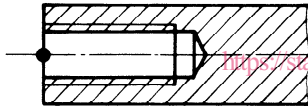

4.4 For a male threaded rod end, the reference point is located on the rod centreline, at the shoulder level :

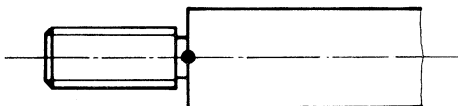

4.5 New types of rod ends can be introduced later as required.

5 Letter codes for identifying cylinder mounting, envelope and accessory dimensions

The code of identification for cylinder mounting, envelope and accessory dimensions is composed of one or two letters and, in some cases, the signs +, ++ or +/.

The meaning of the letters and of the sign + is given in 5.1 to 5.5.

5.1 Letter Z

Any group of two letters beginning with *Z* identifies a longitudinal envelope dimension.

5.2 Letter U

Any group of two letters beginning with *U* identifies an end view envelope dimension.

5.3 Letters W, X, Y, Z

Any group of two letters beginning with *W*, *X*, *Y*, or *Z* identifies a dimension end from the reference point.

5.4 Letter H

Any group of two letters ending with *H* identifies the cylinder centre height with respect to its mounting plane.

5.5 Sign +

The sign + after the letters means that the stroke is to be added :

$$ZJ + = ZJ \text{ plus stroke}$$

The sign ++ after the letters means that twice the stroke is to be added :

$$ZM ++ = ZM \text{ plus twice the stroke}$$

The sign +/ after the letters means that half the stroke is to be added :

$$XV +/ = XV \text{ plus half the stroke.}$$

iTeh STANDARD PREVIEW
(standards.iteh.ai)

SIST ISO 6099:1998
http://standards.iteh.ai/catalog/standards/sist/82707139-b742-4212-9987-3ec8413f07/sist-6099-1998

5.6 Dimensioning

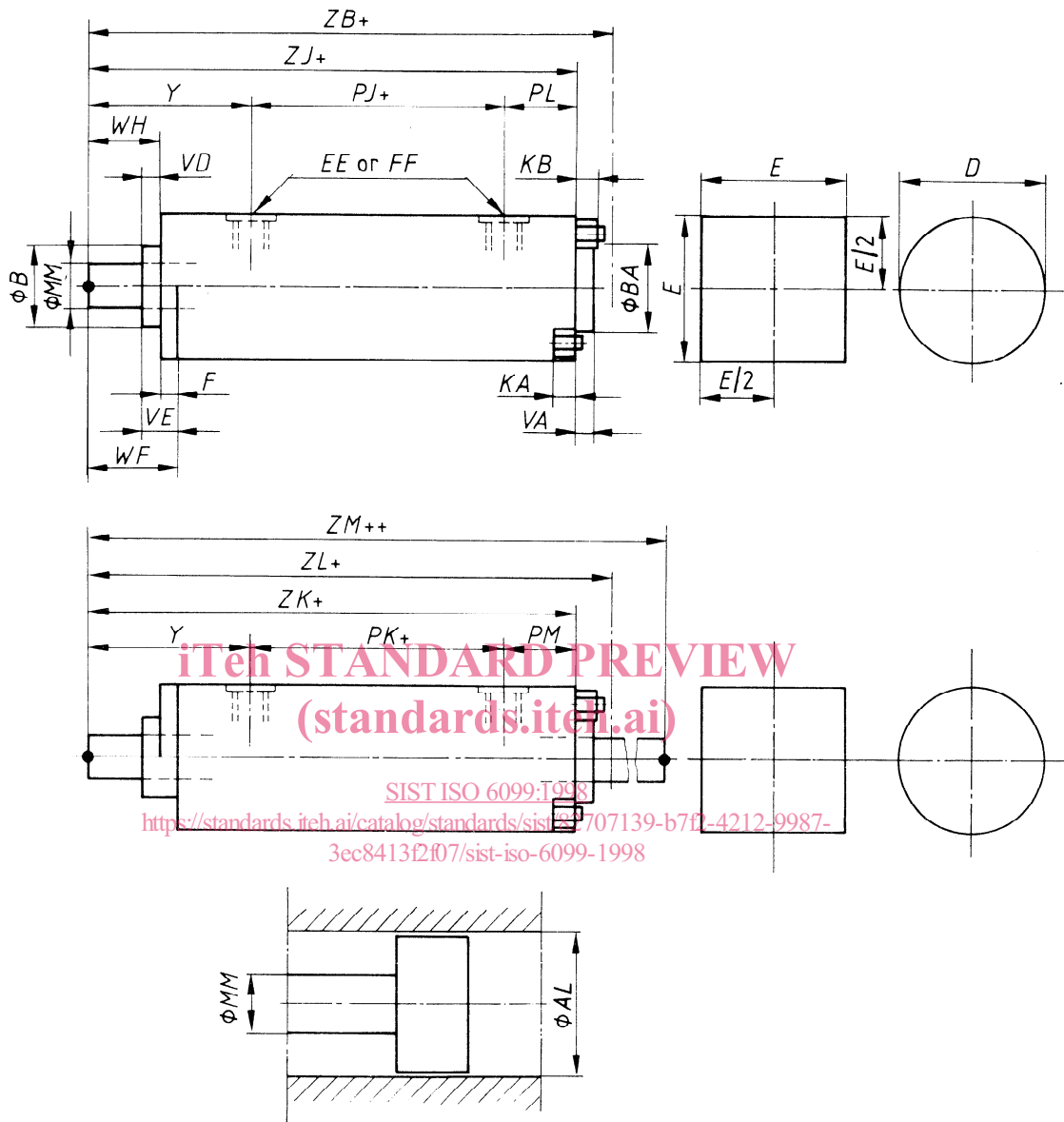

Figure 1 — Arrangement of general cylinder dimensions

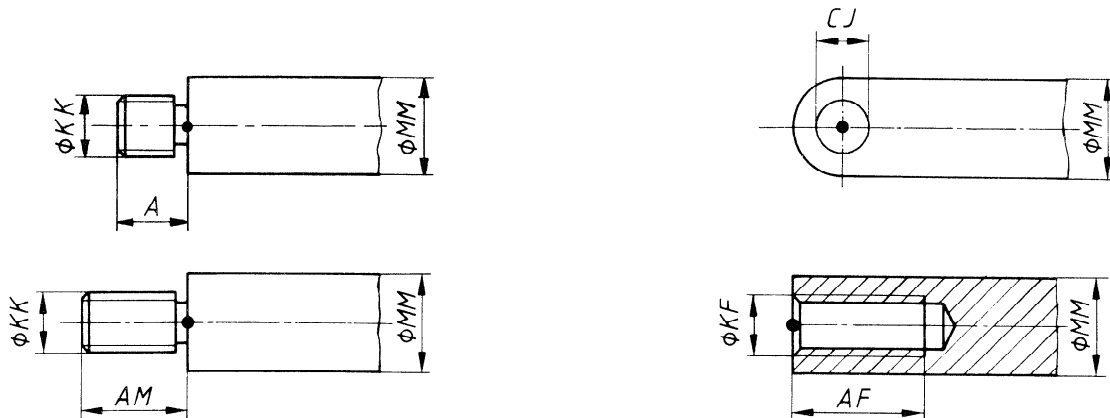
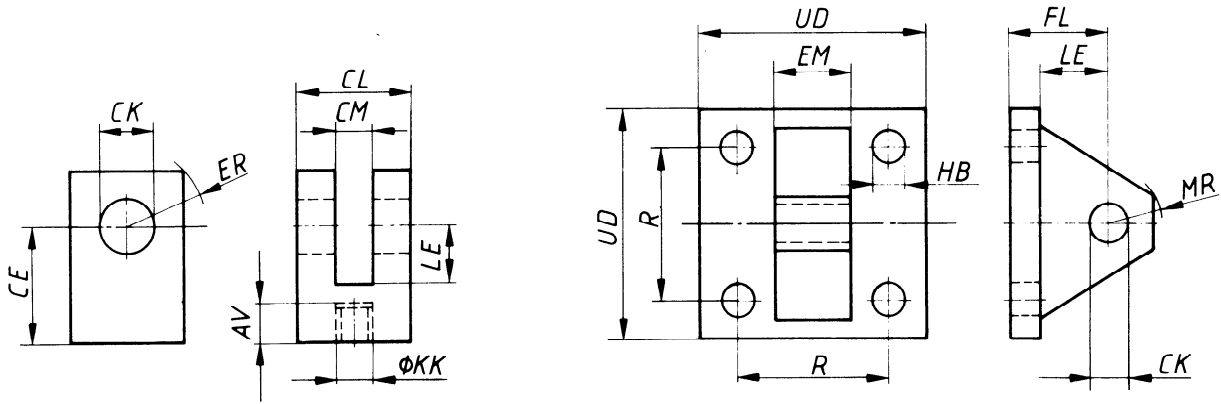

Figure 2 — Rod end dimensions



a) Rod clevis

b) Eye bracket



c) Rod eye, plain

d) Rod eye with spherical plain bearing

<https://standards.iteh.ai/catalog/standards/sist/82707139-b7f2-4212-9987-3ec8413f2f07/sist-iso-6099-1998>

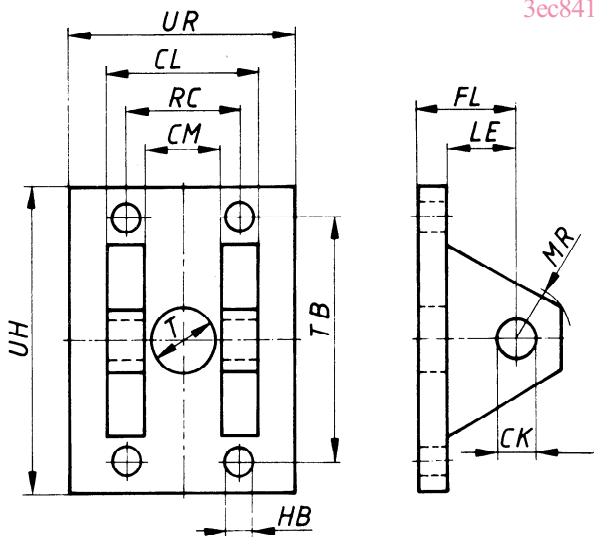

e) Clevis bracket

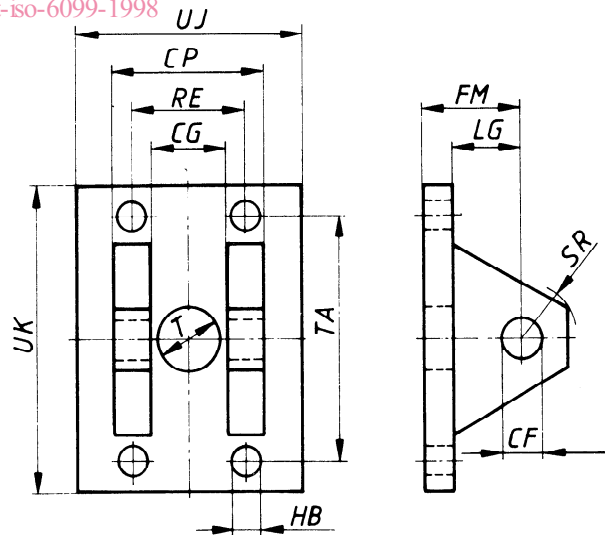

f) Clevis bracket for spherical plain bearing

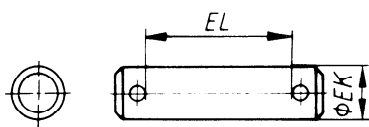

g) Pivot pin, plain (Cotter pin or snap ring type)

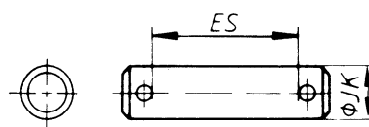

h) Pivot pin, spherical plain bearing (Cotter pin or snap ring type)

Figure 3 – Cylinder accessories

6 Identification code for mounting types

6.1 General

The identification code for cylinder mounting types consists of two or three letters and a number.

Example :

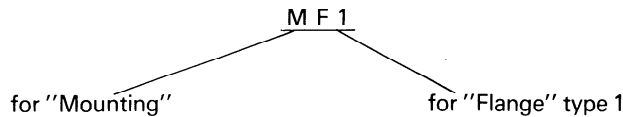

Example :

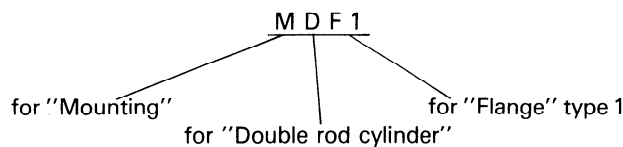

The following letters may be substituted for the letter designating flanges in the examples above :

Letter	Mounting type
E	Cap or head
F	Flange (detachable)
P	Pivot
R	Threaded nose
S	Foot or lugs
T	Trunnion
X	Studs or tie rods

6.2 Mounting types

The following types of mounting are defined in this International Standard :

ME	5	Head, rectangular (Figure 4)
MDE	5	Head, rectangular — Double rod (Figure 5)
ME	6	Cap, rectangular (Figure 6)
ME	7	Head, round (Figure 7)
MDE	7	Head, round — Double rod (Figure 8)
ME	8	Cap, round (Figure 9)
ME	9	Head, square (Figure 10)
MDE	9	Head, square — Double rod (Figure 11)
ME	10	Cap, square (Figure 12)
MF	1	Head, rectangular flange (Figure 13)

MDF	1	Head, rectangular flange — Double rod (Figure 14)
MF	2	Cap, rectangular flange (Figure 15)
MF	3	Head, circular flange (Figure 16)
MDF	3	Head, circular flange — Double rod (Figure 17)
MF	4	Cap, circular flange (Figure 18)
MF	5	Head, square flange (Figure 19)
MDF	5	Head, square flange — Double rod (Figure 20)
MF	6	Cap, square flange (Figure 21)
MF	7	Head, circular flange centred on the rearside (Figure 22)
MDF	7	Head, circular flange centred on the rearside — Double rod (Figure 23)
MF	8	Head, rectangular flange with two holes (Figure 24)
MP	1	Cap, fixed clevis (Figure 25)
MP	2	Cap, detachable clevis (Figure 26)
MP	3	Cap, fixed eye (Figure 27)
MP	4	Cap, detachable eye (Figure 28)
MP	5	Cap, fixed eye with spherical plain bearing (Figure 29)
MP	6	Cap, detachable eye with spherical plain bearing (Figure 30)
MP	7	Head, detachable clevis (Figure 31)
MR	3	Head, threaded (Figure 32)
MDR	3	Head, threaded — Double rod (Figure 33)
MR	4	Cap, threaded (Figure 34)
MS	1	End angles (Figure 35)
MDS	1	End angles — Double rod (Figure 36)
MS	2	Side lugs (Figure 37)
MDS	2	Side lugs — Double rod (Figure 38)
MS	3	Head angle (Figure 39)
MT	1	Head, integral trunnion (male) (Figure 40)
MDT	1	Head, integral trunnion (male) — Double rod (Figure 41)
MT	2	Cap, integral trunnion (male) (Figure 42)
MT	4	Intermediate fixed or movable trunnion (male) (Figure 43)
MDT	4	Intermediate fixed or movable trunnion (male) — Double rod (Figure 44)
MT	5	Head, detachable trunnion (male) (Figure 45)
MT	6	Cap, detachable trunnion (male) (Figure 46)
MX	1	Both ends studs or tie rods extended (Figure 47)
MDX	1	Both ends studs or tie rods extended — Double rod (Figure 48)
MX	2	Cap studs or tie rods extended (Figure 49)
MDX	2	Cap studs or tie rods extended — Double rod (Figure 50)
MX	3	Head studs or tie rods extended (Figure 51)
MX	4	Both ends 2 studs or tie rods extended (Figure 52)
MDX	4	Both ends 2 studs or tie rods extended — Double rod (Figure 53)
MX	5	Head, tapped (Figure 54)
MDX	5	Head, tapped — Double rod (Figure 55)
MX	6	Cap, tapped (Figure 56)

7 Letter codes of mounting and envelope dimensions according to cylinder mounting types

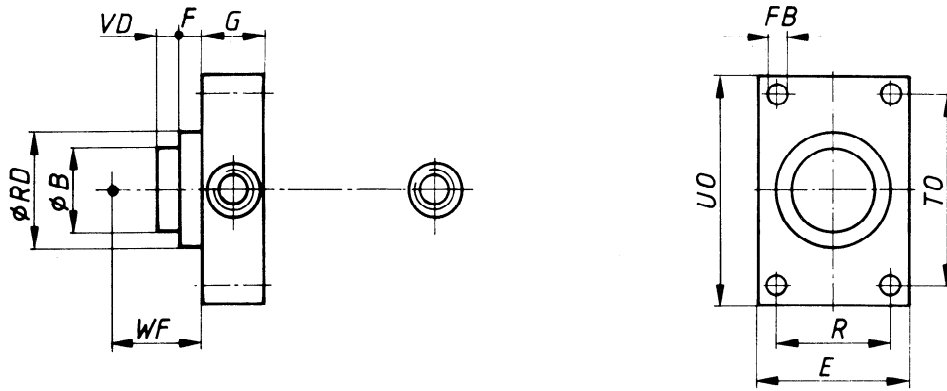

Figure 4 – (ME 5) Head, rectangular

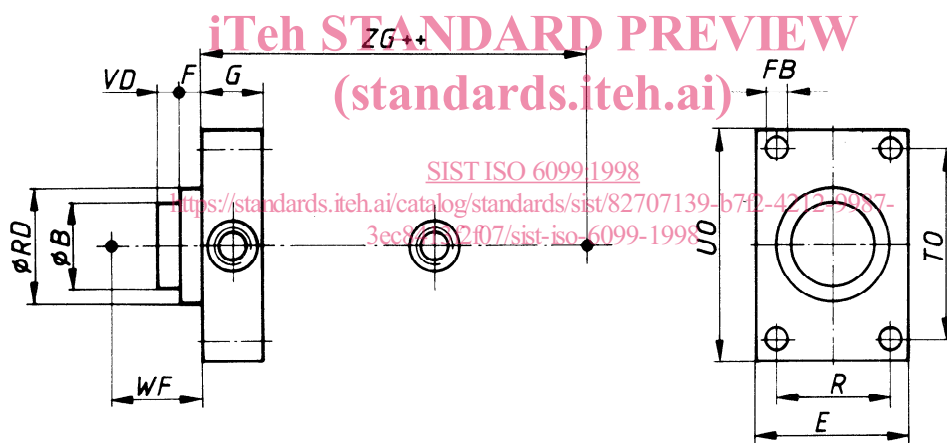

Figure 5 – (MDE 5) Head, rectangular – Double rod

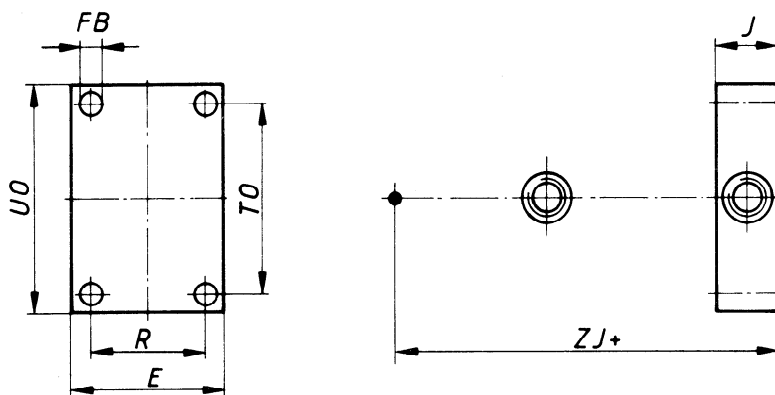

Figure 6 – (ME 6) Cap, rectangular

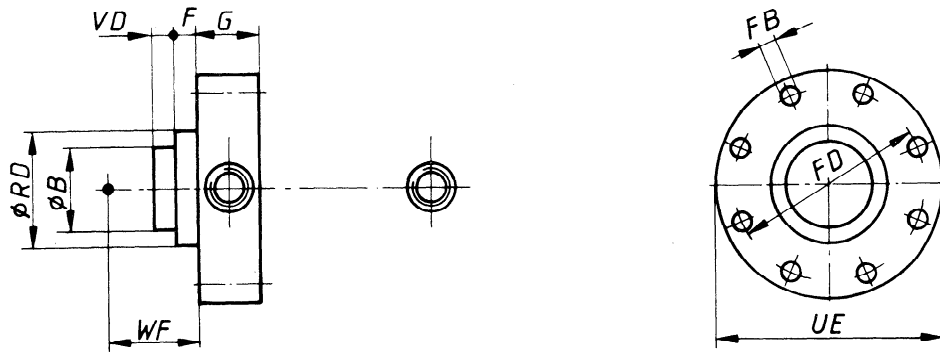

Figure 7 – (ME 7) Head, round

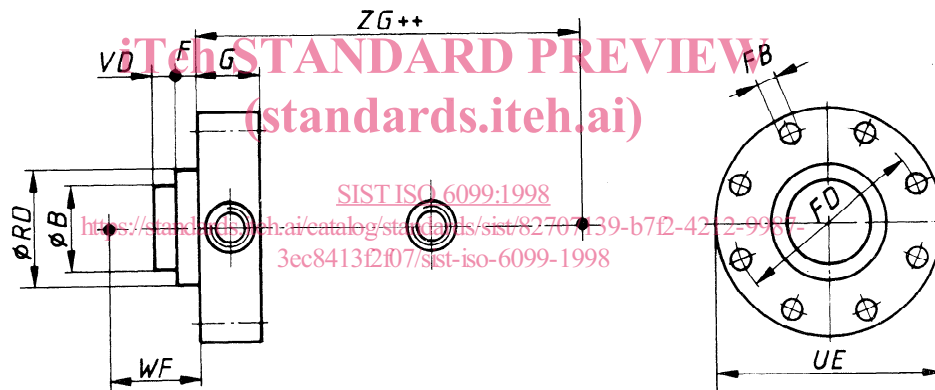

Figure 8 – (MDE 7) Head, round – Double rod

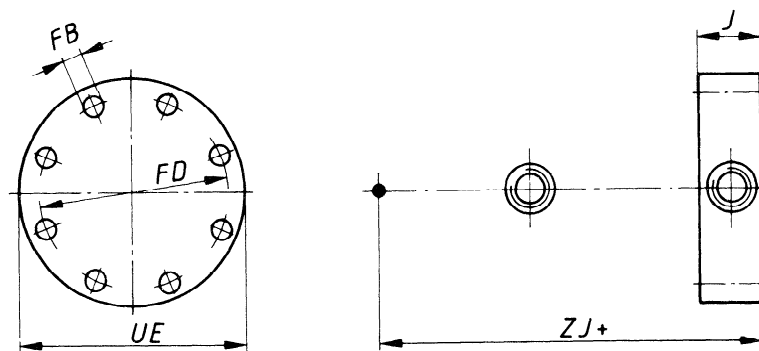

Figure 9 – (ME 8) Cap, round

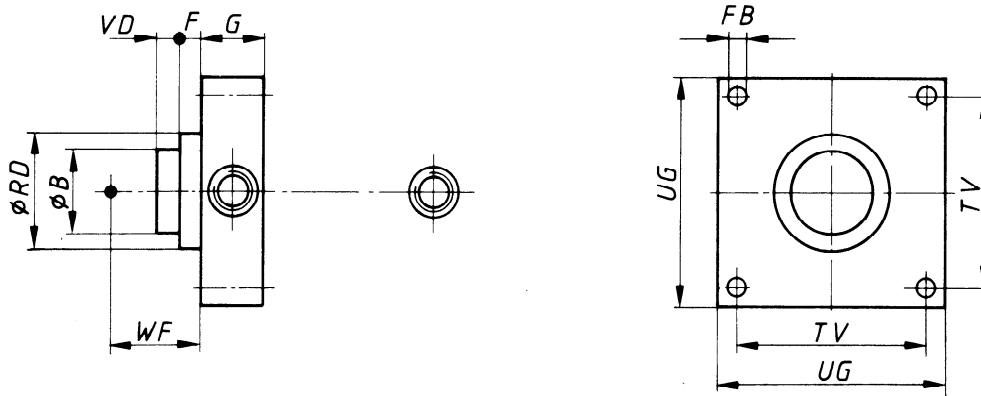

Figure 10 — (ME 9) Head, square

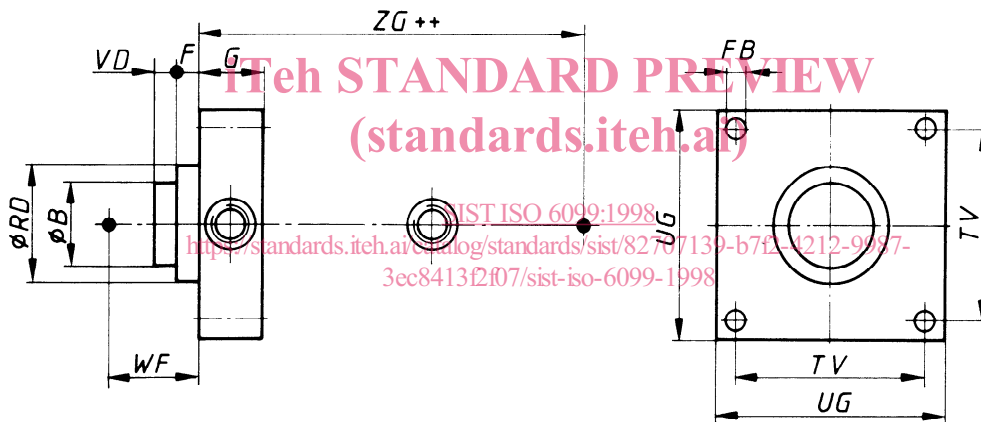

Figure 11 — (MDE 9) Head, square — Double rod

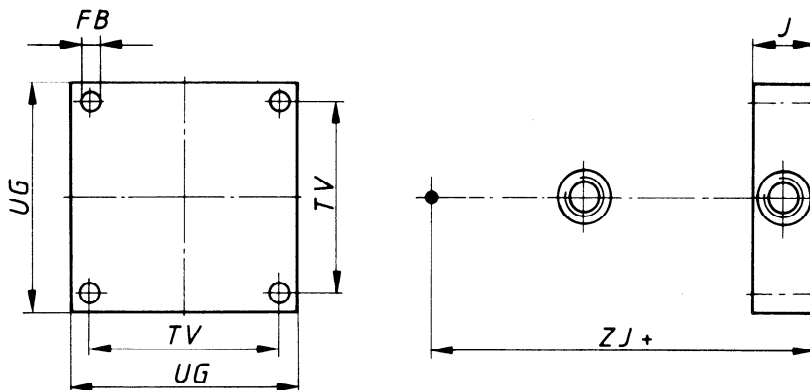

Figure 12 — (ME 10) Cap, square

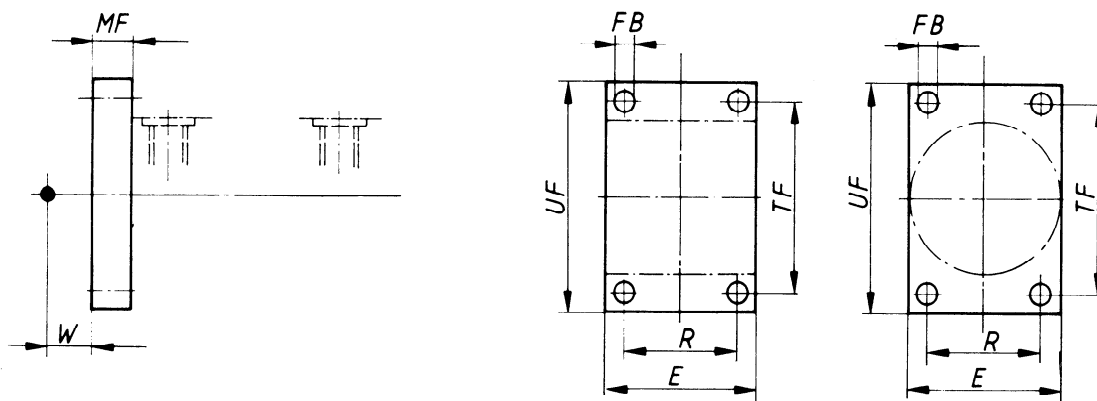

Figure 13 — (MF 1) Head, rectangular flange

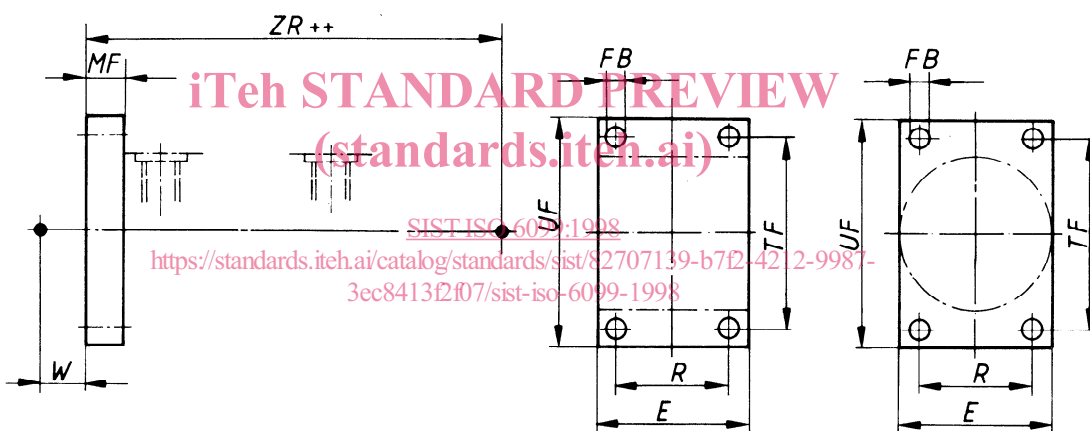

Figure 14 — (MDF 1) Head, rectangular flange — Double rod

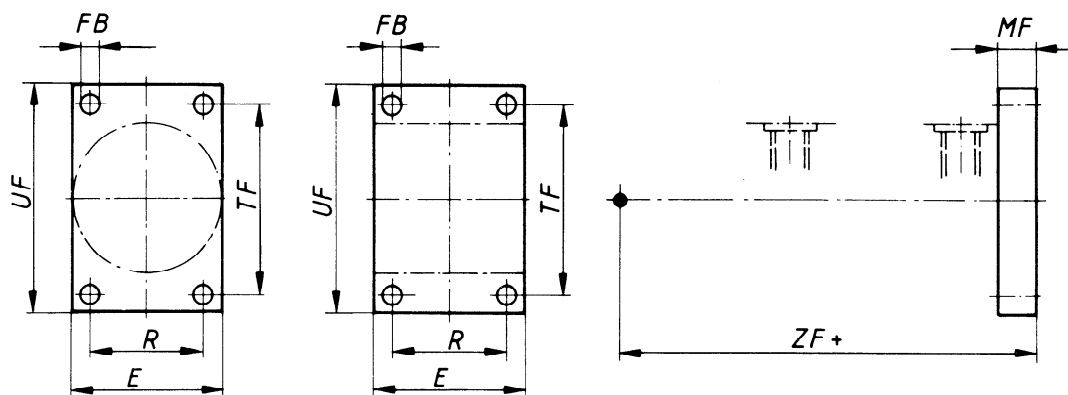

Figure 15 — (MF 2) Cap, rectangular flange