**Fluid power systems and components —
Cylinders — Identification code for
mounting dimensions and mounting types**

*Transmissions hydrauliques — Vérins — Code d'identification des
dimensions de montage et des modes de fixation*

iTeh STANDARD PREVIEW
(standards.iteh.ai)

[ISO 6099:2001](https://standards.iteh.ai/catalog/standards/sist/35005ded-a337-48e6-8f44-3d46f9719745/iso-6099-2001)

<https://standards.iteh.ai/catalog/standards/sist/35005ded-a337-48e6-8f44-3d46f9719745/iso-6099-2001>



PDF disclaimer

This PDF file may contain embedded typefaces. In accordance with Adobe's licensing policy, this file may be printed or viewed but shall not be edited unless the typefaces which are embedded are licensed to and installed on the computer performing the editing. In downloading this file, parties accept therein the responsibility of not infringing Adobe's licensing policy. The ISO Central Secretariat accepts no liability in this area.

Adobe is a trademark of Adobe Systems Incorporated.

Details of the software products used to create this PDF file can be found in the General Info relative to the file; the PDF-creation parameters were optimized for printing. Every care has been taken to ensure that the file is suitable for use by ISO member bodies. In the unlikely event that a problem relating to it is found, please inform the Central Secretariat at the address given below.

iTeh STANDARD PREVIEW
(standards.iteh.ai)

[ISO 6099:2001](#)

<https://standards.iteh.ai/catalog/standards/sist/35005ded-a337-48e6-8f44-3d46f9719745/iso-6099-2001>

© ISO 2001

All rights reserved. Unless otherwise specified, no part of this publication may be reproduced or utilized in any form or by any means, electronic or mechanical, including photocopying and microfilm, without permission in writing from either ISO at the address below or ISO's member body in the country of the requester.

ISO copyright office
Case postale 56 • CH-1211 Geneva 20
Tel. + 41 22 749 01 11
Fax + 41 22 749 09 47
E-mail copyright@iso.ch
Web www.iso.ch

Printed in Switzerland

Contents

Page

Foreword.....	iv
Introduction	v
1 Scope	1
2 Normative reference	1
3 Terms and definitions	1
4 Reference point.....	2
4.1 General.....	2
4.2 Plain rod end	2
4.3 Pin rod end	2
4.4 Female threaded rod end	2
4.5 Male threaded rod end	3
4.6 Wrench flat piston rod end	3
4.7 Flanged piston rod end — Alternative reference points.....	3
5 Letter code for identifying cylinder mounting, envelope and accessory dimensions	4
5.1 General.....	4
5.2 Letter <i>Z</i>	4
5.3 Letter <i>U</i>	4
5.4 Letters <i>W</i> , <i>X</i> , <i>Y</i> , <i>Z</i>	4
5.5 Signs	4
5.6 Dimensioning	4
6 Identification code for accessory types	7
6.1 General.....	7
6.2 Accessory types	7
7 Letter codes of accessories according to accessory type	8
8 Identification code for mounting types	12
8.1 General.....	12
8.2 Mounting types	13
9 Letter codes of mounting and envelope dimensions according to cylinder mounting type.....	15
10 Letter code listing.....	36
11 Identification statement (Reference to this International Standard).....	37

Foreword

ISO (the International Organization for Standardization) is a worldwide federation of national standards bodies (ISO member bodies). The work of preparing International Standards is normally carried out through ISO technical committees. Each member body interested in a subject for which a technical committee has been established has the right to be represented on that committee. International organizations, governmental and non-governmental, in liaison with ISO, also take part in the work. ISO collaborates closely with the International Electrotechnical Commission (IEC) on all matters of electrotechnical standardization.

International Standards are drafted in accordance with the rules given in the ISO/IEC Directives, Part 3.

Draft International Standards adopted by the technical committees are circulated to the member bodies for voting. Publication as an International Standard requires approval by at least 75 % of the member bodies casting a vote.

Attention is drawn to the possibility that some of the elements of this International Standard may be the subject of patent rights. ISO shall not be held responsible for identifying any or all such patent rights.

International Standard ISO 6099 was prepared by Technical Committee ISO/TC 131, *Fluid power systems*, Subcommittee SC 3, *Cylinders*.

This third edition cancels and replaces the second edition (ISO 6099:1985), which has been technically revised.

ITC STANDARD PREVIEW
(standards.iteh.ai)

[ISO 6099:2001](https://standards.iteh.ai/catalog/standards/sist/35005ded-a337-48e6-8f44-3d46f9719745/iso-6099-2001)

<https://standards.iteh.ai/catalog/standards/sist/35005ded-a337-48e6-8f44-3d46f9719745/iso-6099-2001>

Introduction

In fluid power systems, power is transmitted and controlled through a fluid (liquid or gas) under pressure within an enclosed circuit. Systems and their components are generally designed and marketed for a specific fluid pressure.

One such component is the fluid power cylinder. This is a device which converts power into linear mechanical force and motion. It consists of a movable element, i.e. a piston and piston rod, operating within a cylindrical bore.

Although this International Standard provides a code and means of dimensioning for cylinder mounting, it is not intended that all dimensions be standardized. The code specified in this International Standard is not to be considered as complete for the development of future interchangeability standards. It establishes uniform descriptions for dimensions and achieves a conformity of language.

The code can be used for analogous dimensions when this involves neither confusion nor misunderstanding.

iTeh STANDARD PREVIEW (standards.iteh.ai)

ISO 6099:2001

<https://standards.iteh.ai/catalog/standards/sist/35005ded-a337-48e6-8f44-3d46f9719745/iso-6099-2001>

iTeh STANDARD PREVIEW
(standards.iteh.ai)

ISO 6099:2001

<https://standards.iteh.ai/catalog/standards/sist/35005ded-a337-48e6-8f44-3d46f9719745/iso-6099-2001>

Fluid power systems and components — Cylinders — Identification code for mounting dimensions and mounting types

1 Scope

This International Standard establishes a convention for the identification of mounting dimensions and types used in the mounting of fluid power cylinders. It specifies a code for identifying cylinder mounting, envelope, accessory and connector dimensions, and for cylinder mounting and accessory types.

This International Standard does not represent a standard list of all fluid power cylinder mounting and accessory types.

[ISO 6099:2001](https://standards.iteh.ai/catalog/standards/sist/35005ded-a337-48e6-8f44-3d46f9719745/iso-6099-2001)

<https://standards.iteh.ai/catalog/standards/sist/35005ded-a337-48e6-8f44-3d46f9719745/iso-6099-2001>

2 Normative reference

The following normative document contains provisions which, through reference in this text, constitute provisions of this International Standard. For dated references, subsequent amendments to, or revisions of, any of these publications do not apply. However, parties to agreements based on this International Standard are encouraged to investigate the possibility of applying the most recent editions of the normative document indicated below. For undated references, the latest edition of the normative document referred to applies. Members of ISO and IEC maintain registers of currently valid International Standards.

ISO 5598, *Fluid power systems and components — Vocabulary*.

3 Terms and definitions

For the purpose of this International Standard, the terms and definitions given in ISO 5598 apply.

4 Reference point

4.1 General

Axial dimensions are determined from a reference point that is the same for all cylinders, whatever their mounting method. This theoretical reference point (TRP) is the point of force transfer from the piston rod to the movable element.

4.2 Plain rod end

For a plain rod end, the reference point is located on the rod centreline at the end of the piston rod. See Figure 1.

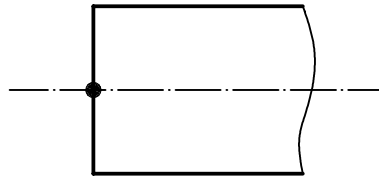

Figure 1 — Plain rod end

4.3 Pin rod end

For a pin rod end, the reference point is located at the intersection of the pin and piston rod centrelines. See Figure 2.

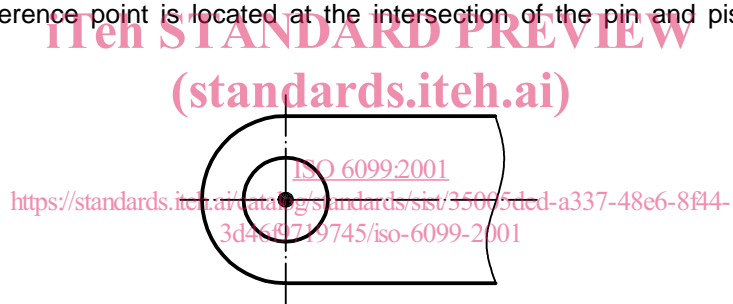

Figure 2 — Pin rod end

4.4 Female threaded rod end

For a female threaded rod end, the reference point is located on the rod centreline at the end of the piston rod. See Figure 3.

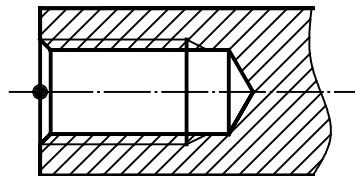

Figure 3 — Female threaded rod end

4.5 Male threaded rod end

For a male threaded rod end, the reference point is located on the rod centreline, at the shoulder level. See Figure 4.

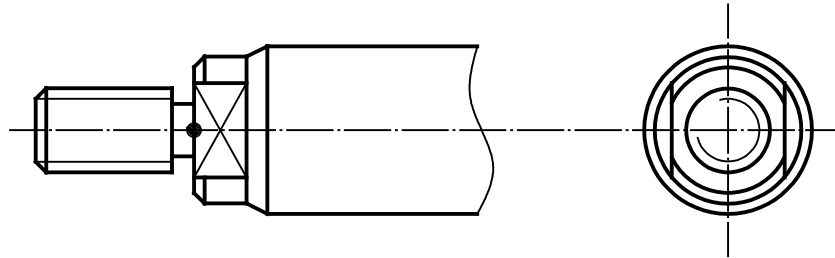

Figure 4 — Male threaded rod end

4.6 Wrench flat piston rod end

For a wrench flat piston rod end, the reference point is located on the wrench flat centreline and the piston rod centreline. See Figure 5.



Figure 5 — Wrench flat rod end
<https://standards.iteh.ai/catalog/standards/sist/89261e1d-37-48e6-8f44-3d46f9719745/iso-6099-2001>

4.7 Flanged piston rod end — Alternative reference points

For a flanged piston rod end, the reference point is either located on the rod centreline at the end of the piston rod (see Figure 6) or on the rod centreline at the shoulder level (see Figure 7).

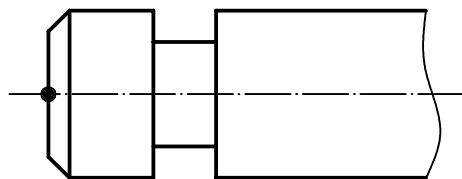

Figure 6 — Flanged piston rod end with TRP at the end of the piston rod

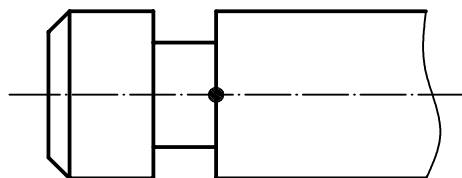

Figure 7 — Flanged piston rod end with TRP at the shoulder level

5 Letter code for identifying cylinder mounting, envelope and accessory dimensions

5.1 General

The code for identifying cylinder mounting, envelope and accessory dimensions is composed of one or two letters and, in some cases, the signs +, ++ or +/.

The meaning of these letters and signs is given in 5.2 to 5.5.

5.2 Letter *Z*

Any group of two letters beginning with *Z* identifies a longitudinal envelope dimension.

5.3 Letter *U*

Any group of two letters beginning with *U* identifies an end view envelope dimension.

5.4 Letters *W, X, Y, Z*

Any group of two letters beginning with *W, X, Y* or *Z* identifies a dimension end from the reference point.

5.5 Signs

The sign + after letters means that the stroke is to be added:

$ZJ + = ZJ$ plus stroke.

The sign ++ after letters means that twice the stroke is to be added:

$ZM ++ = ZM$ plus twice the stroke.

The sign +/ after letters means that half the stroke is to be added:

$XV +/ = XV$ plus half the stroke.

5.6 Dimensioning

The general dimensions are shown in Figure 8, while the rod-end dimensions are shown in Figure 9.

ITeH STANDARD PREVIEW
(standards.iteh.ai)

ISO 6099:2001
<https://standards.iteh.ai/catalog/standards/sist/35005ded-a337-48e6-8f44-3d46f9719745/iso-6099-2001>

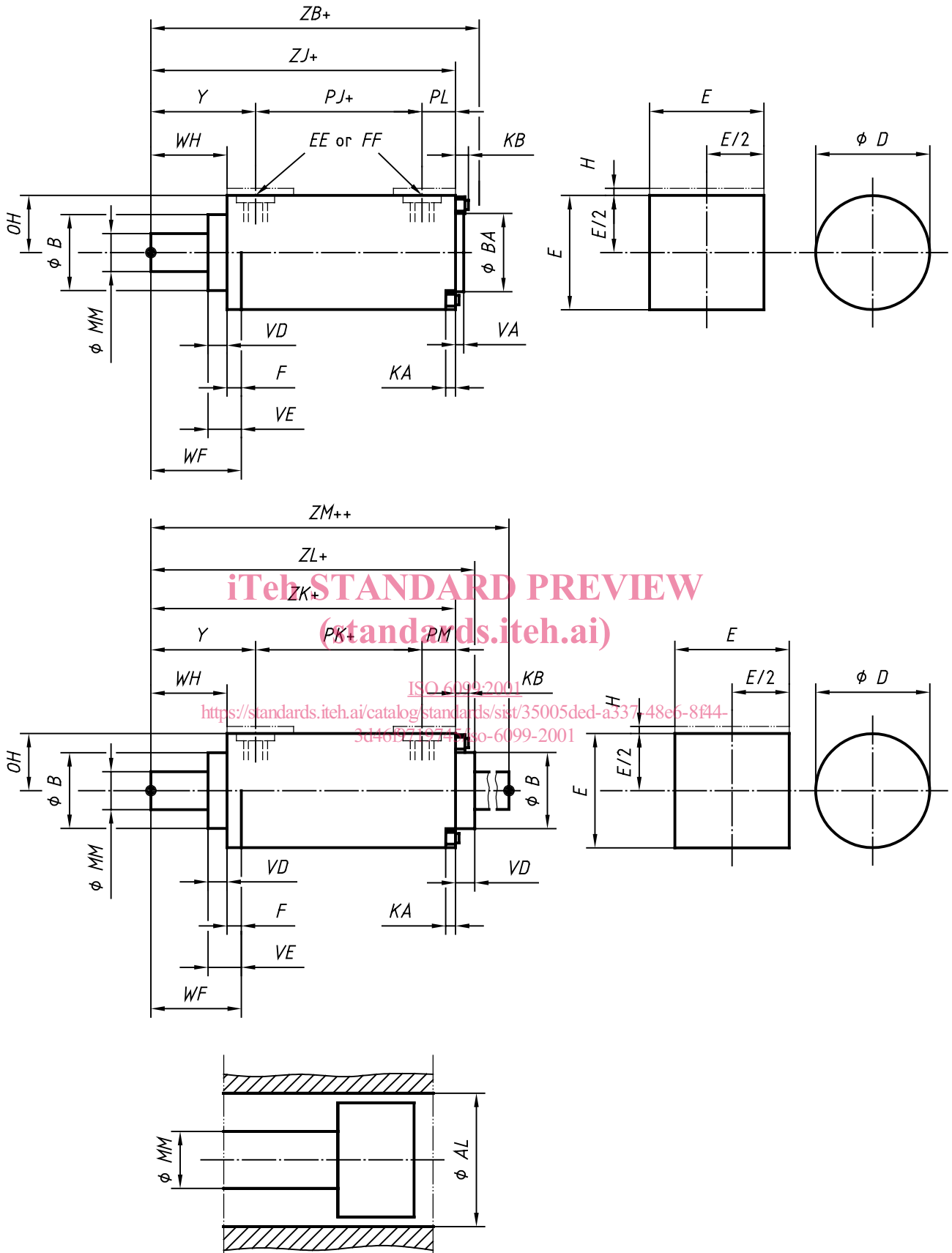

Figure 8 — Arrangement of general cylinder dimensions

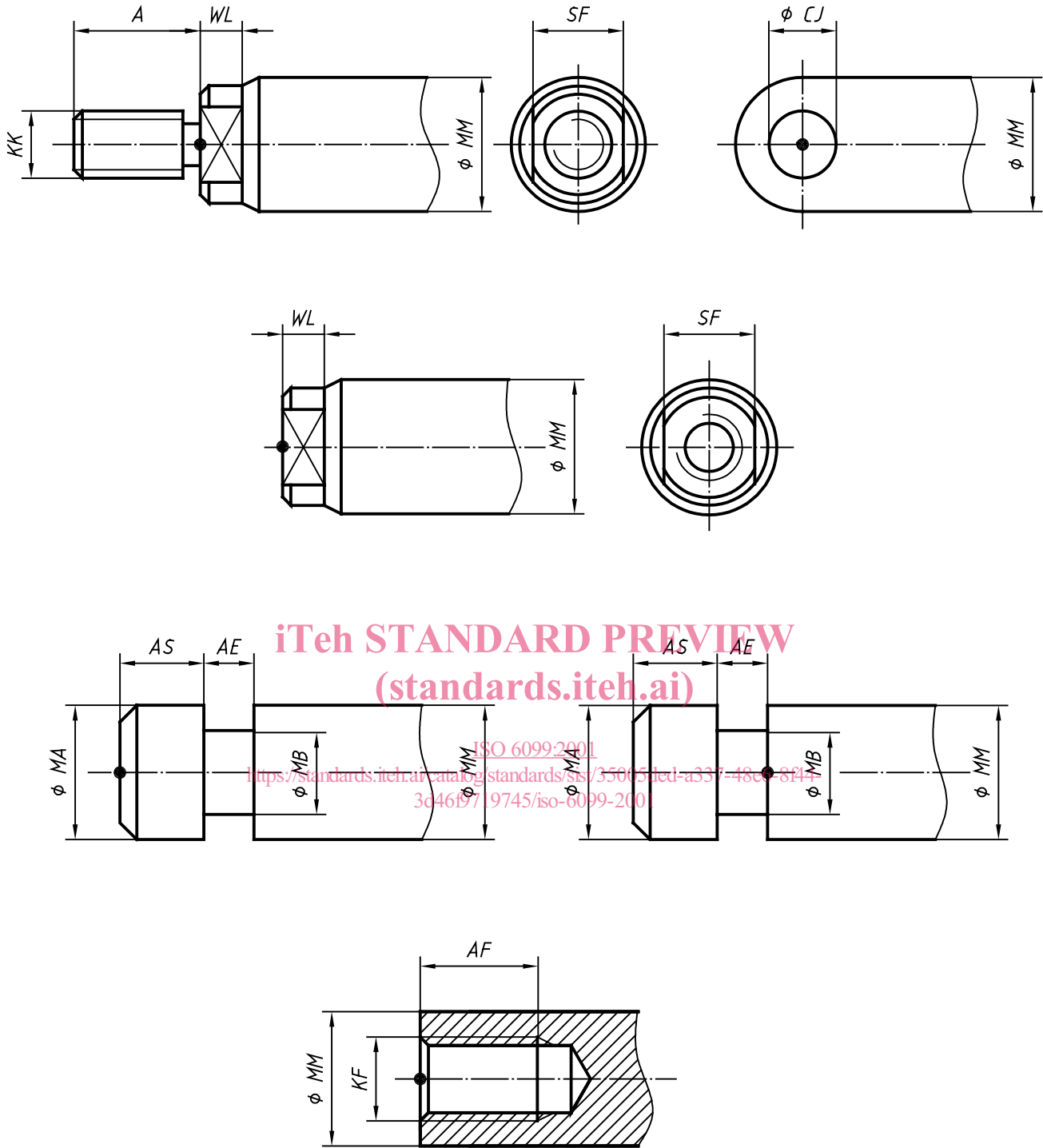

Figure 9 — Rod end dimensions

6 Identification code for accessory types

6.1 General

The identification code for cylinder accessory types consists of two letters and a number.

EXAMPLE

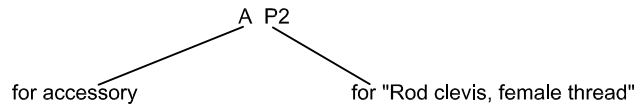

6.2 Accessory types

The accessory types defined in this International Standard are given with their identification code in Table 1.

Table 1 — Accessory types

Identification code	Description	Figure
AA4	Pivot pin, plain	20
AA6	Pivot pin, spherical bearing	21
AA7	Pivot pin, spherical bearing, locking plate	22
AB2	Eye bracket	13
AB3	Clevis bracket, in angle	15
AB4	Clevis bracket, straight	14
AB5	Clevis bracket, spherical eye, in angle	17
AB6	Clevis bracket, spherical eye, straight	16
AB7	Eye bracket, in angle	24
AF3	Rod flange, circular	18
AL7	Locking plate for pivot pin	23
AP2	Rod clevis, female thread	10
AP4	Rod eye plain, female thread	11
AP6	Rod eye spherical, female thread	12
AT4	Trunnion bracket	19

7 Letter codes of accessories according to accessory type

The letter code for accessories according to type is shown in Figures 10 to 24.

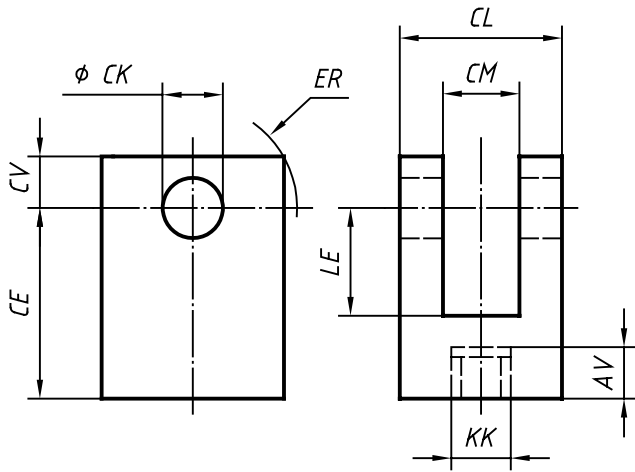

Figure 10 — AP2: Rod clevis, female thread

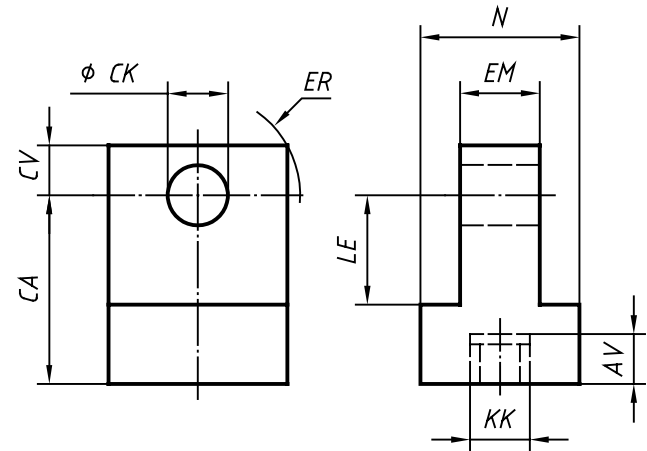

Figure 11 — AP4: Rod eye plain, female thread

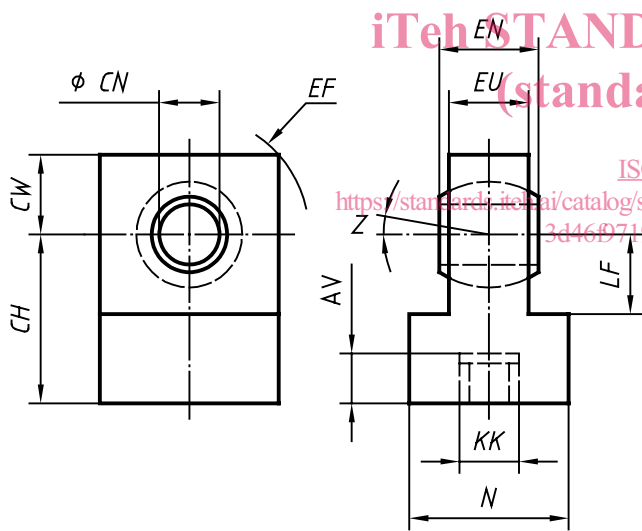

Figure 12 — AP6: Rod eye spherical, female thread

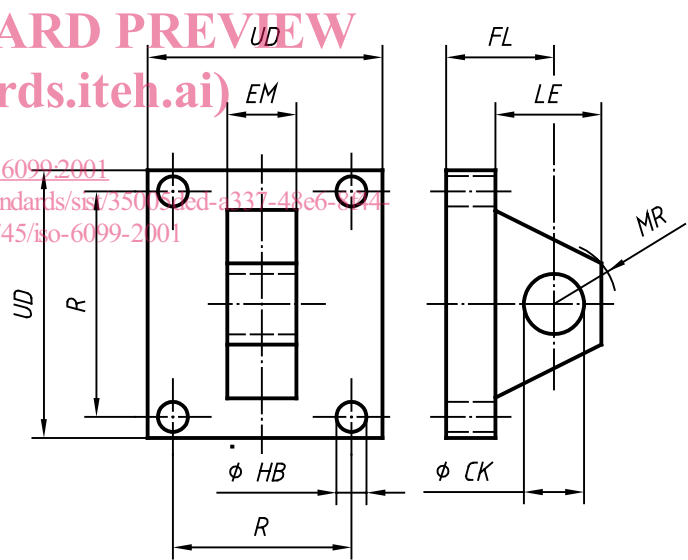

Figure 13 — AB2: Eye bracket

iTeh STANDARD PREVIEW
(standards.iteh.ai)

ISO 6099:2001
<https://standards.iteh.ai/catalog/standards/sis/735055ed-a337-48e6-b744-3d46d719745/iso-6099-2001>

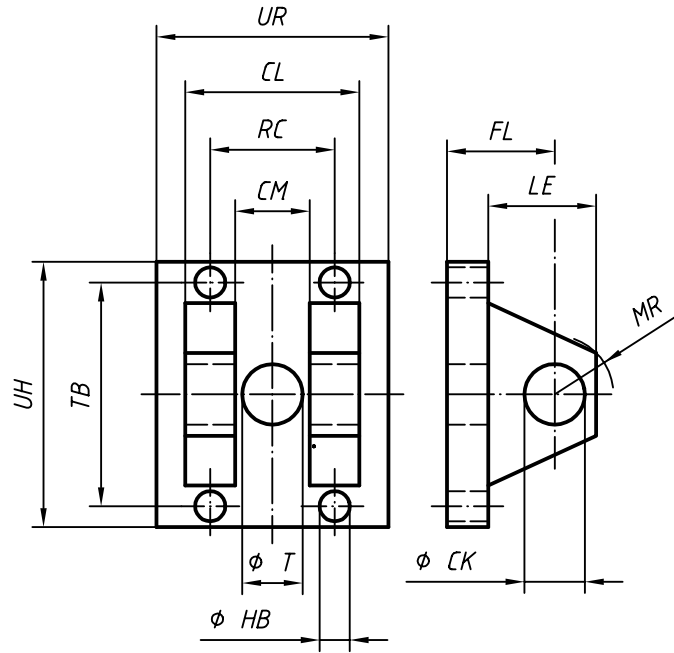

Figure 14 — AB4: Clevis bracket, straight

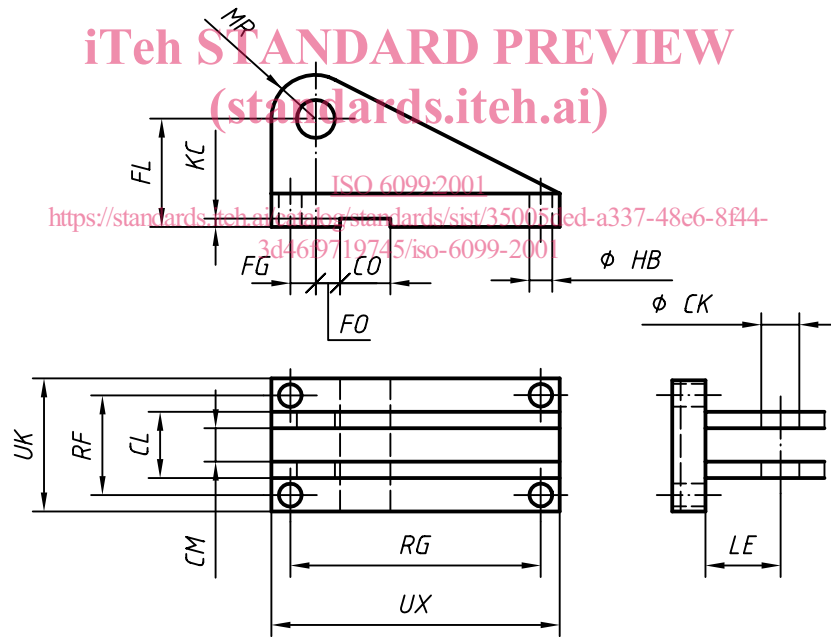

Figure 15 — AB3: Clevis bracket, in angle