

# INTERNATIONAL STANDARD

# NORME INTERNATIONALE



**Lamp controlgear –  
Part 2-12: Particular requirements for d.c. or a.c. supplied electronic ballasts for  
discharge lamps (excluding fluorescent lamps)**

**Appareillages de lampes –  
Partie 2-12: Exigences particulières pour les ballasts électroniques alimentés en  
courant continu ou alternatif pour lampes à décharge (à l'exclusion des lampes  
fluorescentes)**



**THIS PUBLICATION IS COPYRIGHT PROTECTED**  
**Copyright © 2010 IEC, Geneva, Switzerland**

All rights reserved. Unless otherwise specified, no part of this publication may be reproduced or utilized in any form or by any means, electronic or mechanical, including photocopying and microfilm, without permission in writing from either IEC or IEC's member National Committee in the country of the requester. If you have any questions about IEC copyright or have an enquiry about obtaining additional rights to this publication, please contact the address below or your local IEC member National Committee for further information.

Droits de reproduction réservés. Sauf indication contraire, aucune partie de cette publication ne peut être reproduite ni utilisée sous quelque forme que ce soit et par aucun procédé, électronique ou mécanique, y compris la photocopie et les microfilms, sans l'accord écrit de l'IEC ou du Comité national de l'IEC du pays du demandeur. Si vous avez des questions sur le copyright de l'IEC ou si vous désirez obtenir des droits supplémentaires sur cette publication, utilisez les coordonnées ci-après ou contactez le Comité national de l'IEC de votre pays de résidence.

IEC Central Office  
3, rue de Varembe  
CH-1211 Geneva 20  
Switzerland

Tel.: +41 22 919 02 11  
Fax: +41 22 919 03 00  
[info@iec.ch](mailto:info@iec.ch)  
[www.iec.ch](http://www.iec.ch)

#### About the IEC

The International Electrotechnical Commission (IEC) is the leading global organization that prepares and publishes International Standards for all electrical, electronic and related technologies

#### About IEC publications

The technical content of IEC publications is kept under constant review by the IEC. Please make sure that you have the latest edition, a corrigenda or an amendment might have been published.

#### IEC Catalogue - [webstore.iec.ch/catalogue](http://webstore.iec.ch/catalogue)

The stand-alone application for consulting the entire bibliographical information on IEC International Standards, Technical Specifications, Technical Reports and other documents. Available for PC, Mac OS, Android Tablets and iPad.

#### IEC publications search - [www.iec.ch/searchpub](http://www.iec.ch/searchpub)

The advanced search enables to find IEC publications by a variety of criteria (reference number, text, technical committee,...). It also gives information on projects, replaced and withdrawn publications.

#### IEC Just Published - [webstore.iec.ch/justpublished](http://webstore.iec.ch/justpublished)

Stay up to date on all new IEC publications. Just Published details all new publications released. Available online and also once a month by email.

#### Electropedia - [www.electropedia.org](http://www.electropedia.org)

The world's leading online dictionary of electronic and electrical terms containing 20 000 terms and definitions in English and French, with equivalent terms in 15 additional languages. Also known as the International Electrotechnical Vocabulary (IEV) online.

#### IEC Glossary - [std.iec.ch/glossary](http://std.iec.ch/glossary)

65 000 electrotechnical terminology entries in English and French extracted from the Terms and Definitions clause of IEC publications issued since 2002. Some entries have been collected from earlier publications of IEC TC 37, 77, 86 and CISPR.

#### IEC Customer Service Centre - [webstore.iec.ch/csc](http://webstore.iec.ch/csc)

If you wish to give us your feedback on this publication or need further assistance, please contact the Customer Service Centre: [csc@iec.ch](mailto:csc@iec.ch).

#### A propos de l'IEC

La Commission Electrotechnique Internationale (IEC) est la première organisation mondiale qui élabore et publie des Normes internationales pour tout ce qui a trait à l'électricité, à l'électronique et aux technologies apparentées.

#### A propos des publications IEC

Le contenu technique des publications IEC est constamment revu. Veuillez vous assurer que vous possédez l'édition la plus récente, un corrigendum ou amendement peut avoir été publié.

#### Catalogue IEC - [webstore.iec.ch/catalogue](http://webstore.iec.ch/catalogue)

Application autonome pour consulter tous les renseignements bibliographiques sur les Normes internationales, Spécifications techniques, Rapports techniques et autres documents de l'IEC. Disponible pour PC, Mac OS, tablettes Android et iPad.

#### Recherche de publications IEC - [www.iec.ch/searchpub](http://www.iec.ch/searchpub)

La recherche avancée permet de trouver des publications IEC en utilisant différents critères (numéro de référence, texte, comité d'études,...). Elle donne aussi des informations sur les projets et les publications remplacées ou retirées.

#### IEC Just Published - [webstore.iec.ch/justpublished](http://webstore.iec.ch/justpublished)

Restez informé sur les nouvelles publications IEC. Just Published détaille les nouvelles publications parues. Disponible en ligne et aussi une fois par mois par email.

#### Electropedia - [www.electropedia.org](http://www.electropedia.org)

Le premier dictionnaire en ligne de termes électroniques et électriques. Il contient 20 000 termes et définitions en anglais et en français, ainsi que les termes équivalents dans 15 langues additionnelles. Egalement appelé Vocabulaire Electrotechnique International (IEV) en ligne.

#### Glossaire IEC - [std.iec.ch/glossary](http://std.iec.ch/glossary)

65 000 entrées terminologiques électrotechniques, en anglais et en français, extraites des articles Termes et Définitions des publications IEC parues depuis 2002. Plus certaines entrées antérieures extraites des publications des CE 37, 77, 86 et CISPR de l'IEC.

#### Service Clients - [webstore.iec.ch/csc](http://webstore.iec.ch/csc)

Si vous désirez nous donner des commentaires sur cette publication ou si vous avez des questions contactez-nous: [csc@iec.ch](mailto:csc@iec.ch).

# INTERNATIONAL STANDARD

# NORME INTERNATIONALE



## Lamp controlgear –

**Part 2-12: Particular requirements for d.c. or a.c. supplied electronic ballasts for discharge lamps (excluding fluorescent lamps)**

## Appareillages de lampes –

**Partie 2-12: Exigences particulières pour les ballasts électroniques alimentés en courant continu ou alternatif pour lampes à décharge (à l'exclusion des lampes fluorescentes)**

INTERNATIONAL  
ELECTROTECHNICAL  
COMMISSION

COMMISSION  
ELECTROTECHNIQUE  
INTERNATIONALE

ICS 29.140.99

ISBN 978-2-8891-2233-2

**Warning! Make sure that you obtained this publication from an authorized distributor.  
Attention! Veuillez vous assurer que vous avez obtenu cette publication via un distributeur agréé.**

## CONTENTS

FOREWORD.....	3
INTRODUCTION .....	6
1 Scope.....	7
2 Normative references.....	7
3 Definitions .....	7
4 General requirements .....	8
5 General notes on tests .....	8
6 Classification .....	8
7 Marking .....	9
8 Terminals .....	9
9 Provisions for earthing .....	9
10 Protection against accidental contact with live parts .....	10
11 Moisture resistance and insulation.....	10
12 Electric strength .....	10
13 Thermal endurance test for windings .....	10
14 Fault conditions.....	10
15 Protection of associated components.....	10
16 Ignition voltage.....	10
17 Abnormal conditions .....	11
18 Construction .....	15
19 Creepage distances and clearances .....	15
20 Screws, current-carrying parts and connections.....	15
21 Resistance to heat, fire and tracking.....	15
22 Resistance to corrosion.....	15
Annex A (normative) Test to establish whether a conductive part is a live part which may cause an electric shock.....	16
Annex B (normative) Particular requirements for thermally protected lamp controlgear .....	17
Annex C (normative) Particular requirements for electronic lamp controlgear with means of protection against overheating.....	18
Annex D (normative) Information for carrying out the heating tests of thermally protected lamp controlgear .....	19
Annex E (normative) The use of constants S other than 4 500 in $t_w$ tests.....	20
Annex F (normative) Draught-proof enclosure.....	21
Annex G (normative) Explanation of the derivation of the values of pulse voltages .....	22
Annex H (normative) Tests .....	23
Annex I (normative) Precautions to be observed when measuring with spherical spark gaps.....	24
Bibliography.....	25

## INTERNATIONAL ELECTROTECHNICAL COMMISSION

## LAMP CONTROLGEAR –

**Part 2-12: Particular requirements for d.c. or a.c. supplied electronic ballasts for discharge lamps (excluding fluorescent lamps)**

## FOREWORD

- 1) The International Electrotechnical Commission (IEC) is a worldwide organization for standardization comprising all national electrotechnical committees (IEC National Committees). The object of IEC is to promote international co-operation on all questions concerning standardization in the electrical and electronic fields. To this end and in addition to other activities, IEC publishes International Standards, Technical Specifications, Technical Reports, Publicly Available Specifications (PAS) and Guides (hereafter referred to as "IEC Publication(s)"). Their preparation is entrusted to technical committees; any IEC National Committee interested in the subject dealt with may participate in this preparatory work. International, governmental and non-governmental organizations liaising with the IEC also participate in this preparation. IEC collaborates closely with the International Organization for Standardization (ISO) in accordance with conditions determined by agreement between the two organizations.
- 2) The formal decisions or agreements of IEC on technical matters express, as nearly as possible, an international consensus of opinion on the relevant subjects since each technical committee has representation from all interested IEC National Committees.
- 3) IEC Publications have the form of recommendations for international use and are accepted by IEC National Committees in that sense. While all reasonable efforts are made to ensure that the technical content of IEC Publications is accurate, IEC cannot be held responsible for the way in which they are used or for any misinterpretation by any end user.
- 4) In order to promote international uniformity, IEC National Committees undertake to apply IEC Publications transparently to the maximum extent possible in their national and regional publications. Any divergence between any IEC Publication and the corresponding national or regional publication shall be clearly indicated in the latter.
- 5) IEC itself does not provide any attestation of conformity. Independent certification bodies provide conformity assessment services and, in some areas, access to IEC marks of conformity. IEC is not responsible for any services carried out by independent certification bodies.
- 6) All users should ensure that they have the latest edition of this publication.
- 7) No liability shall attach to IEC or its directors, employees, servants or agents including individual experts and members of its technical committees and IEC National Committees for any personal injury, property damage or other damage of any nature whatsoever, whether direct or indirect, or for costs (including legal fees) and expenses arising out of the publication, use of, or reliance upon, this IEC Publication or any other IEC Publications.
- 8) Attention is drawn to the Normative references cited in this publication. Use of the referenced publications is indispensable for the correct application of this publication.
- 9) Attention is drawn to the possibility that some of the elements of this IEC Publication may be the subject of patent rights. IEC shall not be held responsible for identifying any or all such patent rights.

**This consolidated version of the official IEC Standard and its amendment has been prepared for user convenience.**

**IEC 61347-2-12 edition 1.1 contains the first edition (2005) [documents 34C/683/FDIS and 34C/687/RVD] and its amendment 1 (2010) [documents 34C/898/CDV and 34C/933/RVC].**

**A vertical line in the margin shows where the base publication has been modified by amendment 1. Additions and deletions are displayed in red, with deletions being struck through.**

International Standard IEC 61347-2-12 has been prepared by subcommittee 34C: Auxiliaries for lamps, of IEC technical committee 34: Lamps and related equipment.

This publication has been drafted in accordance with the ISO/IEC Directives, Part 2.

This standard shall be used in conjunction with IEC 61347-1. It was established on the basis of the first (2000) edition of that standard.

This part 2 supplements or modifies the corresponding clauses in IEC 61347-1, so as to convert that publication into the IEC Standard: Particular requirements for d.c. or a.c. supplied electronic ballasts for discharge lamps (excluding fluorescent lamps).

NOTE In this standard, the following print types are used:

- requirements: in roman type;
- *test specifications: in italic type*;
- notes: in small roman type.

IEC 61347-2 consists of the following parts, under the general title *Lamp controlgear*:

- Part 1: General and safety requirements
- Part 2-1: Particular requirements for starting devices (other than glow starters)
- Part 2-2: Particular requirements for d.c. or a.c. supplied electronic step-down convertors for filament lamps
- Part 2-3: Particular requirements for a.c. supplied electronic ballasts for fluorescent lamps
- Part 2-4: Particular requirements for d.c. supplied electronic ballasts for general lighting
- Part 2-5: Particular requirements for d.c. supplied electronic ballasts for public transport lighting
- Part 2-6: Particular requirements for d.c. supplied electronic ballasts for aircraft lighting
- Part 2-7: Particular requirements for d.c. supplied electronic ballasts for emergency lighting
- Part 2-8: Particular requirements for ballasts for fluorescent lamps
- Part 2-9: Particular requirements for ballasts for discharge lamps (excluding fluorescent lamps)
- Part 2-10: Particular requirements for electronic invertors and convertors for high-frequency operation of cold start tubular discharge lamps (neon tubes)
- Part 2-11: Particular requirements for miscellaneous electronic circuits used with luminaires
- Part 2-12: Particular requirements for d.c. or a.c. supplied electronic ballasts for discharge lamps (excluding fluorescent lamps)
- Part 2-13: Particular requirements for d.c. or a.c. supplied electronic controlgear for LED modules<sup>1)</sup>

---

<sup>1)</sup> To be published.

The committee has decided that the contents of the base publication and its amendments will remain unchanged until the stability date indicated on the IEC web site under "<http://webstore.iec.ch>" in the data related to the specific publication. At this date, the publication will be

- reconfirmed,
- withdrawn,
- replaced by a revised edition, or
- amended.

**IMPORTANT – The “colour inside” logo on the cover page of this publication indicates that it contains colours which are considered to be useful for the correct understanding of its contents. Users should therefore print this publication using a colour printer.**

iTech Standards  
(<https://standards.iteh.ai>)  
Document Preview

IEC 61347-2-12:2005

<https://standards.iteh.ai/catalog/standards/iec/90c253b2-82f4-4c00-b3e2-33534212ac65/iec-61347-2-12-2005>

## INTRODUCTION

This standard, and the parts which make up IEC 61347-1, in referring to any of the clauses of IEC 61347-1 specify the extent to which such a clause is applicable and the order in which the tests are to be performed; they also include additional requirements as necessary. All parts which make up IEC 61347-2 are self-contained and therefore do not include references to each other.

Where the requirements of any of the clauses of IEC 61347-1 are referred to in this standard by the phrase “The requirements of Clause n of IEC 61347-1 apply, this phrase is interpreted as meaning that all requirements of the clause in question of Part 1 apply, except any which are clearly inapplicable to the specific type of lamp controlgear covered by this particular part of IEC 61347-2.

Withholdam

iTech Standards  
(<https://standards.iteh.ai>)  
Document Preview

<https://standards.iteh.ai/standards/iec/90025362-82f4-4c00-b3e2-33534212ac65/iec-61347-2-12-2005>

<https://standards.iteh.ai/standards/iec/90025362-82f4-4c00-b3e2-33534212ac65/iec-61347-2-12-2005>



## LAMP CONTROLGEAR –

### Part 2-12: Particular requirements for d.c. or a.c. supplied electronic ballasts for discharge lamps (excluding fluorescent lamps)

#### 1 Scope

This part of IEC 61347 specifies particular general and safety requirements for d.c. or a.c. supplied electronic ballasts. The supply comprises a.c. voltages up to 1000 V at 50 Hz/60 Hz. The type of ballast is an converter that may contain igniting and stabilising elements for operation of a discharge lamp at d.c. or at a frequency that can deviate from the supply frequency. The lamps associated with the ballast are specified in IEC 60188 (High pressure mercury vapour lamps), IEC 60192 (Low pressure sodium vapour lamps), IEC 60662 (High pressure sodium vapour lamps), IEC 61167 (Metal halide lamps) and else for general purpose lighting. Ballasts for fluorescent lamps and for lamps for special applications like for theatre and for vehicles are excluded.

#### 2 Normative references

For the purpose of this part of IEC 61347, the normative references given in Clause 2 of IEC 61347-1 apply together with the following:

IEC 60052:2002, *Voltage measurement by means of standard air gaps*

IEC 60417-DB<sup>2)</sup>, *Graphical symbols for use on equipment*

IEC 61347-1, *Lamp controlgear – Part 1: General and safety requirements*

#### 3 Definitions

For the purpose of this part of IEC 61347, the definitions given in Cause 3 of IEC 61347-1 apply together with the following.

##### 3.1

##### **output power**

value of the mean power intended to be provided by an electronic ballast

##### 3.2

##### **output terminals**

ballast terminals, intended to be connected to the HID lamp

NOTE This terminal is not understood as a terminal allowing for intermediate operation of e.g. tungsten halogen lamps.

---

<sup>2)</sup> "DB" refers to the IEC on-line database.

### 3.3

#### ignition voltage

$U_p$

highest value of the voltage generated between the output terminals

NOTE 1 Basically, the following types of pulses are comprised:

- a) continuous r.m.s. working voltage with superimposed non-sinusoidal single pulse;
- b) continuous sinusoidal pulse voltage;
- c) continuous sinusoidal pulse voltage with superimposed non-sinusoidal single pulse;
- d) continuous square wave voltage with ringing sinusoidal voltage at each transition.

NOTE 2 The term 'pulse' is to be distinguished from the term 'surge' which refers to transients occurring in electrical equipment or networks in service.

### 3.4

#### spherical spark gap

two metal spheres of the same nominal diameter arranged at a specified distance and used under specified conditions for the measurement of peak voltages in excess of 15 kV

## 4 General requirements

The requirements of Clause 4 of IEC 61347-1 apply.

## 5 General notes on tests

The requirements of Clause 5 of IEC 61347-1 apply together with the following additional requirements:

### 5.1 Number of specimens

The following number of specimens shall be submitted for testing:

- one unit for the tests of Clauses 6 to 12 and 15 to 22;
- one unit for the tests of Clause 14; fault conditions (additional units or components, where necessary, may be required in consultation with the manufacturer).

5.2 Void.

## 6 Classification

The requirements of Clause 6 of IEC 61347-1 apply together with the following additional requirement:

### 6.1 Ignition voltage

Ballasts are classified according to ignition voltage:

- up to and including 5 kV;
- greater than 5 kV, and up to and including 10 kV;
- greater than 10 kV, and up to and including 100 kV.

6.2 Void.

## 7 Marking

Ballasts which form an integral part of the luminaire need not be marked. The requirements of 7.2 of IEC 61347-1 apply.

### 7.1 Mandatory markings

Ballasts, other than integral ballasts, shall be clearly and durably marked, in accordance with the requirements of 7.1 of IEC 61347-1, with the following mandatory markings:

- Items a), b), c), d), e), f), k) and l) of 7.1 of IEC 61347-1;
- for controllable ballasts, the control terminals shall be identified;
- output terminals shall be identified as such;
- the value of the ignition voltage (16), if it exceeds 1 500 V. Connections having this voltage shall be marked; for ballasts with an ignition voltage over 5 kV, this marking shall be a flash symbol, see IEC 60417-5036 (DB:2002-10);
- a declaration of the maximum working voltage (r.m.s.) according to 15.1 between
  - output terminals;
  - any output terminal and earth, if applicable.

The specification of each of these values shall be given in the manufacturer's description in steps of 10 V when the working voltage is equal to or less than 500 V, and in steps of 50 V when the working voltage is higher than 500 V.

The highest of the specified voltage values shall be marked on the ballast as "output working voltage = xx V" (or "U-OUT = xx V").

### 7.2 Information to be provided, if applicable

In addition to the above mandatory markings, the following information, if applicable, shall be given either on the ballast, if declared below, or be made available in the manufacturer's catalogue or the like.

Items h), i), j), m) and n) of 7.1 of IEC 61347-1 together with:

- in the case of a ballast consisting of more than one separate unit, all parts have to be marked such that the matching components can be identified clearly;
- warning to the installer to prevent overheating of ballasts and associated components in a multi ballast installation mounted in poles, boxes etc.;
- an indication of the time limitation of ignition voltage;
- If the control terminal is not basic insulated from the mains, this shall be indicated on the ballast.

## 8 Terminals

The requirements of Clause 8 of IEC 61347-1 apply.

## 9 Provisions for earthing

The requirements of Clause 9 of IEC 61347-1 apply.

## 10 Protection against accidental contact with live parts

The requirements of Clause 10 of IEC 61347-1 apply.

## 11 Moisture resistance and insulation

The requirements of Clause 11 of IEC 61347-1 apply.

## 12 Electric strength

The requirements of Clause 12 of IEC 61347-1 apply.

## 13 Thermal endurance test for windings

The requirements of Clause 13 of IEC 61347-1 do not apply.

## 14 Fault conditions

The requirements of Clause 14 of IEC 61347-1 apply.

## 15 Protection of associated components

Output voltages measured shall be those between all output terminals and any output terminal and earth.

**15.1** Under normal and abnormal operating conditions none of these output voltages shall exceed the working voltage as declared by the manufacturer. The ignition phase being defined by switch on or beginning of the ignition process up to the time limit as given in Clause 16 is exempted.

**15.2** Under normal and abnormal (see Clause 17) conditions, if a time limitation is declared for ignition, it shall not be exceeded.

**15.3** For controllable electronic ballasts, the control terminal shall be isolated from the mains circuit by an insulation at least equal to basic insulation unless otherwise indicated, see 7.2.

## 16 Ignition voltage

### 16.1 Instruments

Measurements are made by oscilloscope or electrostatic voltmeters for ignition voltages up to 100 kV.

NOTE A typical electrostatic voltmeter is prescribed in Figure 1 of IEC 61347-2-1.

Many electronic ballasts cannot have grounded outputs. In case a differential probe has to be used, it may have an impedance greater than 1 MΩ at up to 10 kHz. For higher frequencies  $f$  the probe must have an impedance  $Z$  greater than a 15 pF capacitor (C) based on the equation

$$Z = 1/(2\pi f C)$$

The cut-off frequency should be  $\geq 30$  MHz at  $-3$ dB.

Above 15 kV a spherical spark gap can be used, using the procedure based on that given in IEC 60052, and taking note of Annex I.

In case of doubt, the measurement with the electrostatic voltmeter shall be the reference method.

## 16.2 Ignition voltage limits

The maximum value of the ignition voltage shall not exceed 5 kV when operated at the rated voltage and with a load capacitance of 20 pF (including the capacitance of the probe), or using the circuit shown in Figure 1 of IEC 61347-2-1 for either positive or negative pulses, taking into account however, the maximum ignition voltage specified in the relevant lamp data sheets.

If not otherwise stated on the relevant lamp data sheets, for electronic ballasts with ignition voltages over 5 kV, the maximum value shall not exceed  $1,3 \times U_p$  declared by the manufacturer when operated at the rated supply voltage and with a load capacitance of 20 pF.

NOTE In some countries, the ignition voltage is restricted to 4 kV.

## 16.3 Ignition time cut-out

Electronic ballasts equipped with cut-outs shall be of such a construction that, in the case of non-igniting lamps, the cut-out interrupts at least the production of the ignition voltage.

After the cut-out has interrupted the circuit, the generation of the ignition voltage is allowed either after disconnecting and reconnecting the ballast to the supply or by control signal.

Electronic ballasts with ignition voltages over 5 kV shall be provided with a cut-out for igniting. Time to cut-out is limited:

- for ignition voltages 5 to 10 kV to 60 s,
- for ignition voltages > 10 kV a) to 3 s, or b) to 30 s, if declared in the manufacturer's literature.

The cut-out time of 60 s for ignition voltage from 5 kV to 10 kV can be extended, depending on the lamp type, up to a period of 20 min within which the combined intervals of ignition attempts add up to 60 s, provided it is evident for the maintenance service staff that the controlgear is still trying to ignite.

## 17 Abnormal conditions

~~The ballast shall not impair safety when operated under abnormal conditions at any voltage between 90 % and 110 % of rated supply voltage. The range of rated supply voltage may be declared differently by the manufacturer.~~

~~Compliance is checked by the following test.~~

~~Each of the following conditions shall be applied with the ballast operating to the manufacturer's instructions (including a heat sink, if specified) for 1 h:~~

- a) lamp is not inserted or does not ignite;
- b) burner leaks;
- c) the lamp operates, but rectifies.

Condition a) is tested with open output.

Condition b) is tested with circuit in Figure 1 (see below).

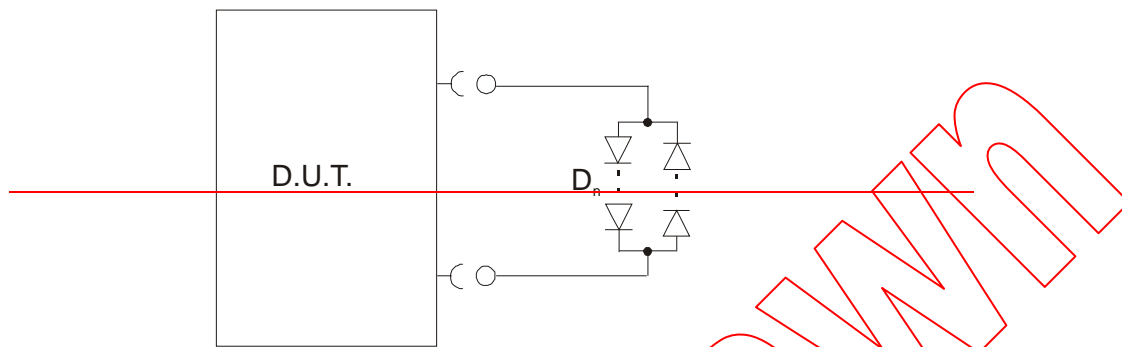

**Key**

D.U.T.: Device under test

D<sub>n</sub>: circuit of some diodes in series, and anti parallel to them, the same number of diodes in series which yields a voltage of 10 V to 15 V across them.

**Figure 1 – Circuit to test whether a ballast can withstand a leaking burner**

Condition c) is tested with circuit in Figure 2 (see below).

Both current directions have to be checked: ballast terminal 1 with circuit wire 1 and ballast terminal 1 with circuit wire 2.

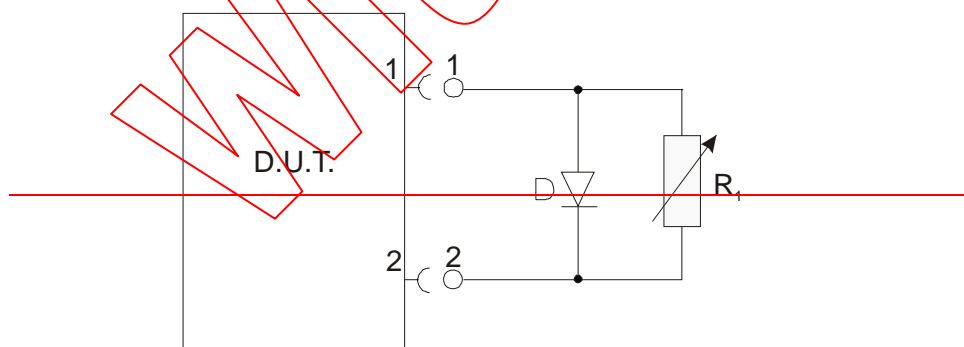

**Key**

D.U.T.: Device under test

D: 100 A, 600 V

R1: 0...200 Ω (wattage rating of the resistor to be at least ½ lamp wattage)

**Figure 2 – Circuit to test whether a ballast can withstand rectification**