

---

# International Standard



# 6103

---

INTERNATIONAL ORGANIZATION FOR STANDARDIZATION • МЕЖДУНАРОДНАЯ ОРГАНИЗАЦИЯ ПО СТАНДАРТИЗАЦИИ • ORGANISATION INTERNATIONALE DE NORMALISATION

---

## **Bonded abrasive products — Static balancing of grinding wheels — Testing**

*Produits abrasifs agglomérés — Équilibrage statique des meules — Contrôle*

**First edition — 1986-12-15**

**iTeh STANDARD PREVIEW**  
**(standards.iteh.ai)**

ISO 6103:1986

<https://standards.iteh.ai/catalog/standards/sist/d39b1314-377f-4bdd-90f2-13ae7e204c7b/iso-6103-1986>

---

**UDC 621.922.0.25-56**

**Ref. No. ISO 6103-1986 (E)**

**Descriptors :** tools, abrasives, grinding wheels, balancing, specifications, tests.



# Bonded abrasive products – Static balancing of grinding wheels – Testing

## 1 Scope and field of application

This International Standard specifies the maximum permissible values of unbalance for various types of grinding wheels in the as-delivered condition, with outside diameter equal to or greater than 125 mm and with a peripheral speed greater than or equal to 16 m/s.

It also specifies the method for measuring the unbalance and the practical method for testing whether a grinding wheel is acceptable or not.

This International Standard applies to bonded abrasive grinding wheels in the as-delivered condition.

This International Standard does not apply to

- diamond, cubic boron nitride or natural stone grinding wheels;
- centreless control wheels, lapping and disc wheels, ball wheels or glass grinding wheels.

### NOTES

- 1 The values given refer to the grinding wheel itself, independent of any unbalance which may exist in the balancing arbor or in the means of fastening it to this arbor. These various elements, together with the flanges or hub-flanges, are assumed to be balanced, homogeneous and free from geometrical defects.
- 2 The effects of unbalance are basically
  - additional stresses on the arbor, the machine and its mounting;
  - excessive wear of the bearings;
  - vibration prejudicial to the quality of machining and increased internal stresses in the grinding wheel;
  - increased operator fatigue.

## 2 Reference

ISO 1925, *Balancing – Vocabulary*.

## 3 Definitions

**3.1 unbalance:** The product of an offset, in millimetres, and a mass, in grams; the unbalance is therefore expressed in grams millimetres.

**3.2 intrinsic unbalance of a grinding wheel,  $U_i$ :** The product of the mass  $m_1$  of the grinding wheel and the distance  $e$  between its centre of mass  $G$  (centre of gravity) and the axis  $O$  of its bore (see figure 1).

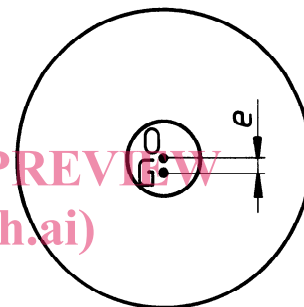

$$U_i = m_1 \cdot e$$

Figure 1

**3.3 measured unbalance,  $U_c$ :** The product of a mass  $m_2$ , affixed to the grinding wheel to balance it, and the distance between the centre of mass  $G_{m_2}$  (centre of gravity) of the mass  $m_2$  and the axis  $O$  of the grinding wheel bore; in practice, this distance is equal to the radius  $r$  of the grinding wheel (see figure 2).

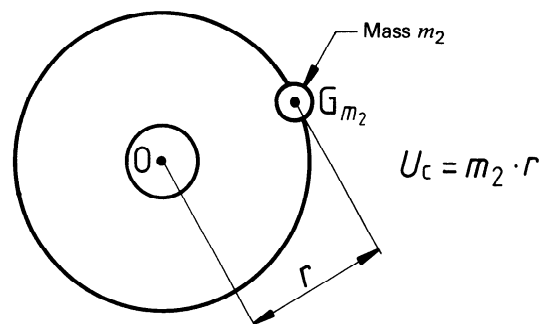

$$U_c = m_2 \cdot r$$

Figure 2

#### 4 Permissible unbalance, $U_a$

On the basis of experience, the maximum permissible unbalance  $U_a$  is determined using a mass  $m_a = U_a/r$ , such that

$$m_a = k \sqrt{m_1}$$

where

$m_a$  is the mass whose centre is located on the circumference of the grinding wheel, in grams;

$m_1$  is the mass of the grinding wheel, in grams;

$r$  is the radius of the grinding wheel, in millimetres;

$k$  is a coefficient which depends on the nature and usage of the grinding wheel.

The values of  $k$  are given in the table and the values of  $m_a$ , as a function of  $m_1$  and  $k$ , are shown in figure 5.

The values of  $k$  have been selected on the basis of experience so that the resulting unbalance allows for normal usage of the grinding wheel.

#### 5 Measurement of the intrinsic unbalance

Place a balancing arbor through the bore of the grinding wheel to hold its mid-plane in a vertical position. For plain wheels or wheels of similar shape, the wheel is free-standing; wheels of other shapes may be supported using suitable flanges.

Rest the balancing arbor on two parallel horizontal bevelled guide-bars or cylindrical bars (figure 3), or on a balancing stand consisting of two pairs of overlapping, freely rotating steel discs (figure 4), so that the grinding wheel attains an equilibrium position with a minimum of friction.

The clearance between the balancing arbor and the bore of the grinding wheel shall not exceed 0,4 mm.

The arbor and the supports (guide-bars, bars or discs) shall have an adequate surface hardness and an appropriate surface condition to minimize friction.

When the grinding wheel attains the equilibrium position, its centre of mass is then as low as possible. In this position, mark the upper peripheral point of the grinding wheel.

Rotate the grinding wheel through 90° to bring this mark into the horizontal plane of the arbor axis.

Determine the mass  $m_2$  which, when affixed to the periphery of the grinding wheel at a position at right angles to the mark, maintains the grinding wheel in equilibrium. The amount of unbalance thus introduced,  $U_c = m_2 \cdot r$ , is equal and opposite to the intrinsic balance of the wheel.

The value of the mass  $m_2$  is used to determine the intrinsic unbalance of the wheel using the following formula:

$$U_i = U_c = m_2 \cdot r$$

#### 6 Checking the intrinsic unbalance

A grinding wheel is only acceptable if its intrinsic unbalance  $U_i$  is less than or equal to the permissible unbalance  $U_a$ , i.e.

$$U_i \leq U_a$$

The testing is done with a mass

$$m_a = \frac{U_a}{r}$$

##### 6.1 Determination of $m_a$

From the table, determine the coefficient  $k$  by reading off the value according to the various parameters related to the grinding wheel and its application.

Figure 5 then gives the value of the mass  $m_a$ , in grams, as a function of the mass  $m_1$  of the wheel, in grams, and the coefficient  $k$ .

##### 6.2 Acceptance testing of the grinding wheel

With the grinding wheel mounted in accordance with the instructions given in clause 5, place a mass  $m_a$  as determined in 6.1 on the periphery of the grinding wheel at the mark. If the wheel remains stationary or rotates so that the mark is at the bottom, the grinding wheel is accepted. Otherwise, it is rejected.

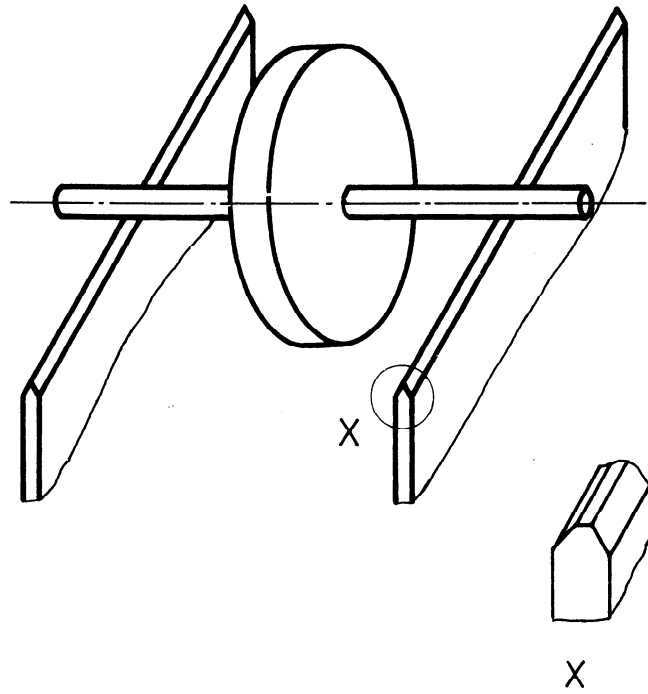

**iTeh STANDARD PREVIEW**  
**Alternative:** The two bevelled guide-bars may be replaced by two cylindrical bars.  
**(standards.iteh.ai)**

**ISO 6 Figure 3**

<https://standards.iteh.ai/catalog/standards/sist/d39b1314-377f-4bdd-90f2-13ae7e204c7b/iso-6103-1986>

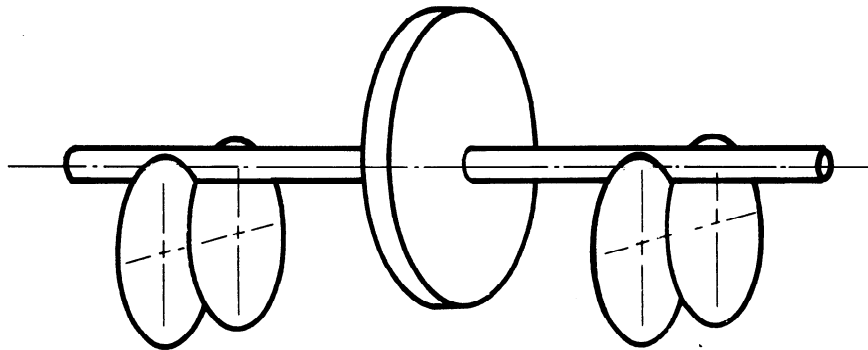

**Figure 4**

Table — Values of the coefficient  $k$ 

Use	Machines	Grinding wheels		Coefficient $k$		
				$16 < v^{1)} < 40$	$40 < v < 63$	$63 < v < 100$
Snagging and fettling	Portable	All types		0,40	0,32	0,25
	Stationary machines Swing-frame machines Other machines	All types		0,63	0,50	0,40
	Fixed high pressure machines	Organic bond, high density, grinding wheels		0,80	0,63	0,50
Precision : — cylindrical grinding — surface grinding — sharpening	Stationary machines Other fixed machines	All types	$D^{2)} < 305$	0,25	0,20	0,16
			$305 < D < 610$	0,32	0,25	0,20
			$D > 610$	0,40	0,32	0,25
Cutting	Portable	All types		—	0,32	0,25
	Stationary or oscillating	All types	$D < 305$	0,50	0,40	0,32
			$D > 305$	0,63	0,50	0,40

1)  $v$  is the maximal peripheral speed of the wheel, in metres per second.

2)  $D$  is the nominal diameter of the wheel, in millimetres.

## iTeh STANDARD PREVIEW (standards.iteh.ai)

ISO 6103:1986

<https://standards.iteh.ai/catalog/standards/sist/d39b1314-377f-4bdd-90f2-13ae7e204c7b/iso-6103-1986>

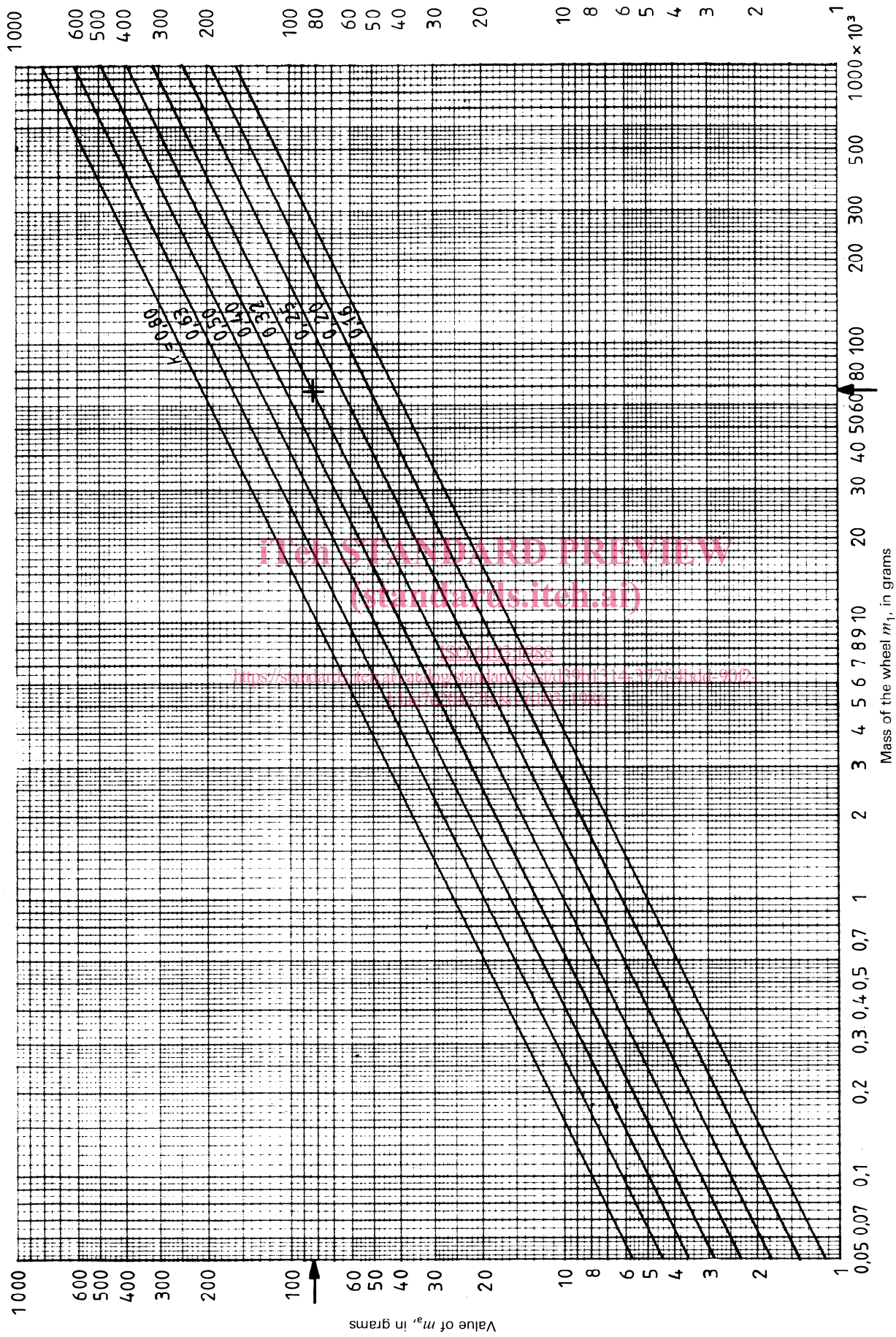

Figure 5

Example:

For a plain wheel for precision grinding, of outside diameter  $D = 760$  mm and mass  $m_1 = 68\ 000$  g used on a stationary machine at a surface speed of 60 m/s, the coefficient  $k = 0,32$  (see the table) and the maximum permissible mass  $m_3 = 83$  g.

## iTeh STANDARD PREVIEW

This page intentionally left blank  
(standards.iteh.ai)

ISO 6103:1986

<https://standards.iteh.ai/catalog/standards/sist/d39b1314-377f-4bdd-90f2-13ae7e204c7b/iso-6103-1986>