International Standard



6123/3

INTERNATIONAL ORGANIZATION FOR STANDARDIZATION • МЕЖДУНАРОДНАЯ ОРГАНИЗАЦИЯ ПО СТАНДАРТИЗАЦИИ • ORGANISATION INTERNATIONALE DE NORMALISATION

Rubber- or plastics-covered rollers — Specifications — Part 3: Dimensional tolerances

Cylindres revêtus de caoutchouc ou de plastique — Spécifications — Partie 3: Tolérances dimensionnelles

First edition — 1985-09-15

ITeH STANDARD PREVIEW
(standards.iteh.ai)

ISO 6123-3:1985

<https://standards.iteh.ai/catalog/standards/sist/d57bf98a-24d4-49d4-9fc0-7b77db66a66e/iso-6123-3-1985>

UDC 678.06 : 62-434 : 621.753.1

Ref. No. ISO 6123/3-1985 (E)

Descriptors : rubber products, plastics products, rollers, specifications, dimensional tolerances, form tolerances.

Foreword

ISO (the International Organization for Standardization) is a worldwide federation of national standards bodies (ISO member bodies). The work of preparing International Standards is normally carried out through ISO technical committees. Each member body interested in a subject for which a technical committee has been established has the right to be represented on that committee. International organizations, governmental and non-governmental, in liaison with ISO, also take part in the work.

Draft International Standards adopted by the technical committees are circulated to the member bodies for approval before their acceptance as International Standards by the ISO Council. They are approved in accordance with ISO procedures requiring at least 75 % approval by the member bodies voting.

International Standard ISO 6123/3 was prepared by Technical Committee ISO/TC 45, *Rubber and rubber products*.

ISO 6123-3:1985
<https://standards.iteh.ai/catalog/standards/sist/d57bf98a-24d4-49d4-9fc0-7b77db66a66e/iso-6123-3-1985>

Rubber- or plastics-covered rollers — Specifications — Part 3: Dimensional tolerances

iTeh STANDARD PREVIEW (standards.iteh.ai)

0 Introduction

Covered rollers are cylindrical cores, generally of metal, with a cover of rubber or plastics for a particular use. They are manufactured in a wide variety of sizes and hardness grades depending on the intended use.

ISO 6123 consists of the following parts:

- Part 1: Requirements for hardness.
- Part 2: Surface characteristics.
- Part 3: Dimensional tolerances.

1 Scope and field of application

This part of ISO 6123 specifies classes of dimensional tolerances for rubber- or plastics-covered rollers and tests methods for the measurement of dimensions.

2 References

ISO 471, *Rubber — Standard temperatures, humidities and times for the conditioning and testing of test pieces.*

ISO 1101, *Technical drawings — Geometrical tolerancing — Tolerances of form, orientation, location and run-out — Generalities, definitions, symbols, indications on drawings.*

ISO/TR 7621, *Rubber or plastics covered rollers — Enquiries and orders — Recommendations for technical information to be supplied by the purchaser.*

3 Definitions

3.1 crown (of a rubber- or plastics-covered roller): The difference between the diameter in the centre of the roller and the diameter at or near the edges of the roller.

The profiles and dimensions of crown are referred to and measured on the measured crown face (MCF).

For definition of the *profile tolerance* of the MCF see ISO 1101, sub-clause 14.5.

NOTES

- 1 Normally the crown is positive. If the covered roller is larger in diameter at the ends than in the centre it is called an inverse crown.
- 2 Unless otherwise specified, a crown is symmetrical above the centre-line of the roller which is the centre-line of the MCF.
- 3 Two types of crown are usual:
 - a) taper crown where there is a linear change in diameter with distance along the roller face from around the centre-line;
 - b) crown where the variation in diameter is non-linear, for example cosine crown.
- 4 Normally the MCF starts 50 mm in from the ends of the roller cover or from the ends of any edge relief such as taper, chamfer or dub.
- 5 Conventionally the MCF is divided into ten equally spaced parts from end to centre, i.e. total 20 parts. The crown shape is described by ten readings from end to centre, i.e. total 21 diametral readings.

3.2 cylindricity tolerance

See ISO 1101, sub-clause 14.4.

3.3 run-out tolerance

See ISO 1101, sub-clause 14.13.1.

3.4 Other terms

For *cover face length*, *cover thickness*, *cover outside diameter (finished diameter)*, *core outside diameter*, *taper*, *chamfer*, and *dub*, see ISO/TR 7621, figure 1.

4 Test methods

4.1 Test temperature

Measurement shall be carried out at a standard temperature ($23 \pm 2 \text{ }^\circ\text{C}$ or $27 \pm 2 \text{ }^\circ\text{C}$) in accordance with ISO 471, when and where possible. The covered roller shall be brought to the test temperature prior to measuring to ensure temperature equilibrium.

As dimensions can be affected by temperature, the same test temperature shall be used throughout any one test or series of tests intended to be comparable. If this condition cannot be met, it is necessary to consider the influence of temperature on the used compound in order to compare the results correctly.

The measuring temperature shall be recorded.

4.2 Test instruments

The dimensions of the rubber- or plastics-covered rollers, the deviation from cylindricity and the run-out shall be measured by suitable instruments.

Calipers and dial-gauges shall be used with plungers or rolls which shall exert a pressure of $22 \pm 5 \text{ kPa}$ for rubber or plastics of hardness equal to or greater than 35 IRHD or of $10 \pm 2 \text{ kPa}$ for hardness less than 35 IRHD.

NOTE — The following instruments can be taken as suitable :

- a) tape measures (with or without vernier), sliding calipers or micrometer calipers for diameters and lengths;
- b) sliding calipers, micrometer calipers or roll calipers with dial indicator gauge for crown and cylindricity;
- c) dial indicator gauges for run-out.

5 Classes of dimensional tolerances

This part of ISO 6123 specifies six classes of tolerances as follows :

XXP	Very high precision
XP	High precision
P	Precision
H	High quality
Q	Quality
N	Non-critical

The class specified depends on the type of roller and the requirements of the application.

Within a single roller a different class may apply to each of the dimensions in clauses 6 to 9.

It should be noted (see clauses 6, 8 and 9) that the closest tolerances are not applicable to all hardnesses of the cover. In general, soft covers need greater tolerances than harder ones.

Class N tolerances are to be used when the roller specification does not indicate a required tolerance class.

NOTE — Nominal dimensions in tables 1 to 6 are based on the R 5 series of preferred numbers.

6 Dimensional tolerances on roller diameter

6.1 General

The permissible tolerance depends on the length and rigidity of the roller and the hardness of the cover. The class shall be taken from table 1 or table 2.

When the thickness of the cover is specified the tolerance shall be based on the diameter of the finished roller being the core diameter plus two times the cover thickness.

A change of tolerances in either direction is permissible, so that, for example, the permissible tolerance of $\pm 0,4$ may also be stated as

$$\begin{matrix} +0,2 & \text{or} & +0,8 & \text{or} & 0 & \text{etc.} \\ -0,6 & & 0 & & -0,8 & \end{matrix}$$

6.2 Roller length to diameter ratio up to 15

Diameter tolerances for rollers of sufficient rigidity and with a length of cover of up to 15 times the core diameter are specified in table 1-1985

6.3 Roller length to diameter ratio between 15 and 25

Diameter tolerances for rollers of sufficient rigidity and with a length of cover above 15 and up to 25 times the core diameter are specified in table 2.

6.4 Other rollers

Diameter tolerances for rollers of insufficient rigidity or with a length of cover above 25 times the core diameter shall be agreed between the interested parties.

7 Dimensional tolerances on cover length

The permissible cover length tolerance shall be taken from the classes in table 3.

Class XP (high precision) applies to a roller with uncovered ends where the cover face terminates plane with the core end. The tolerance is based not on the nominal but on the real length of the core.

A change of tolerances in either direction is permissible, so that, for example, the permissible tolerance of $\pm 0,8$ may also be stated as

$$\begin{matrix} +0,4 & \text{or} & +1,6 & \text{or} & 0 & \text{etc.} \\ -1,2 & & 0 & & -1,6 & \end{matrix}$$

Table 1

Hardness		Class					
IRHD Shore A	Pusey and Jones						
< 50	> 120	—	—	—	H	Q	N
50 to 70	120 to 70	—	—	P	H	Q	N
> 70 to < 100	< 70 to 10	—	XP	P	H	Q	N
≈ 100	9 to 0	XXP	XP	P	H	Q	N
Nominal roller cover diameter (mm)		Diameter tolerance (mm)					
< 40		± 0,04	± 0,06	± 0,10	± 0,15	± 0,3	± 0,5
> 40 to < 63		± 0,05	± 0,07	± 0,15	± 0,20	± 0,3	± 0,6
> 63 to < 100		± 0,06	± 0,09	± 0,15	± 0,25	± 0,4	± 0,7
> 100 to < 160		± 0,07	± 0,11	± 0,20	± 0,30	± 0,5	± 0,9
> 160 to < 250		± 0,08	± 0,14	± 0,25	± 0,40	± 0,6	± 1,1
> 250 to < 400		± 0,11	± 0,18	± 0,30	± 0,50	± 0,8	± 1,4
> 400 to < 630		± 0,14	± 0,23	± 0,40	± 0,65	± 1,1	± 1,8
> 630		— *	± 0,50	± 0,75	± 1,25	± 2,0	± 3,0

* XPP—tolerances for diameters above nominal dimension 630 shall be agreed between the interested parties.

iTeh STANDARD PREVIEW

Table 2

Hardness		Class					
IRHD Shore A	Pusey and Jones						
< 50	> 120	—	—	H	Q	N	
50 to 70	120 to 70	—	—	H	Q	N	
> 70 to < 100	< 70 to 10	—	XP	P	H	Q	N
≈ 100	9 to 0	XXP	XP	P	H	Q	N
Nominal roller cover diameter (mm)		Diameter tolerance (mm)					
< 40		± 0,06	± 0,10	± 0,15	± 0,3	± 0,5	± 0,8
> 40 to < 63		± 0,07	± 0,15	± 0,20	± 0,3	± 0,6	± 1,0
> 63 to < 100		± 0,09	± 0,15	± 0,25	± 0,4	± 0,7	± 1,2
> 100 to < 160		± 0,11	± 0,20	± 0,30	± 0,5	± 0,9	± 1,5
> 160 to < 250		± 0,14	± 0,25	± 0,40	± 0,6	± 1,1	± 1,8
> 250 to < 400		± 0,18	± 0,30	± 0,50	± 0,8	± 1,4	± 2,3
> 400 to < 630		± 0,23	± 0,40	± 0,65	± 1,1	± 1,8	± 3
> 630		± 0,50	± 0,75	± 1,25	± 2,0	± 3,0	± 5

Table 3

Values in millimetres

Nominal cover face length	Class		
	XP	O	N
	Length tolerance		
< 250	± 0,2	± 0,5	± 1,0
> 250 to < 400	± 0,2	± 0,8	± 1,5
> 400 to < 630	± 0,2	± 1,0	± 2,0
> 630 to < 1 000	± 0,2	± 1,0	± 2,5
> 1 000 to < 1 600	± 0,2	± 1,5	± 3,0
> 1 600 to < 2 500	± 0,2	± 1,8	± 3,5
> 2 500	± 0,2	± 0,08 %	± 0,15 %

8 Run-out tolerances

The permissible tolerances depend on the hardness of the cover and the diameter of the roller. When the thickness of the cover is specified the tolerances shall be based on the diameter of the finished roller being the core diameter plus twice the cover thickness.

Run-out tolerances (see figure 1) for rollers of sufficient rigidity are specified in table 4. Tolerances for rollers of insufficient rigidity shall be agreed between the interested parties.

NOTE — For run-out tolerance testing, the roller circumferential speed should not exceed 30 m/min.

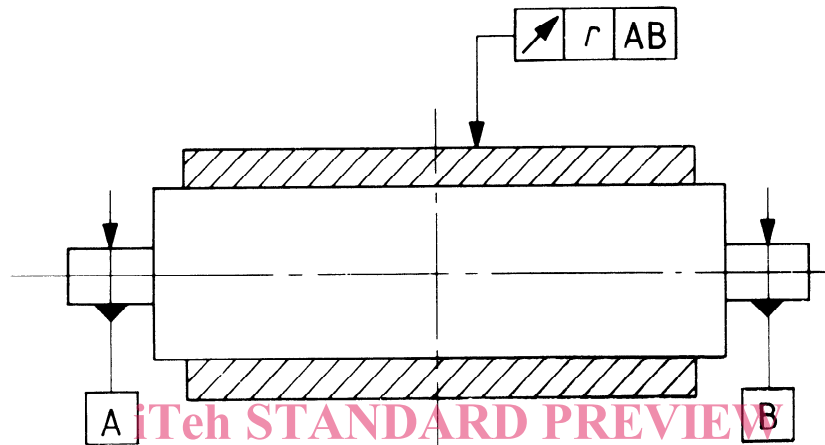

(standards.iteh.ai)

Figure 1 — Run-out tolerances

ISO 6123-3:1985

<https://standards.iteh.ai/catalog/standards/sist/d57bf98a-24d4-49d4-9fc0-7b77db66a66e/iso-6123-3-1985>

Table 4

Hardness		Class				
IRHD Shore A	Pusey and Jones					
< 50	> 120	—	—	H	Q	N
50 to 70	120 to 70	—	P	H	Q	N
> 70 to < 100	< 70 to 10	—	P	H	Q	N
≈ 100	9 to 0	XP	P	H	Q	N
Nominal roller cover diameter (mm)		Run-out tolerance, <i>r</i> (mm)				
< 40		0,01	0,02	0,04	0,08	0,15
> 40 to < 63		0,02	0,03	0,06	0,10	0,18
> 63 to < 100		0,03	0,04	0,08	0,13	0,20
> 100 to < 160		0,03	0,05	0,10	0,17	0,25
> 160 to < 250		0,03	0,06	0,12	0,20	0,30
> 250 to < 400		0,04	0,07	0,14	0,23	0,35
> 400 to < 630		0,04	0,08	0,18	0,30	0,45
> 630		0,05	0,10	0,25	0,35	0,55

9 Cylindricity or crown tolerances

9.1 Cylindricity tolerances

The permissible tolerances depend on the hardness of the cover and the diameter of the roller. When the thickness of the cover is specified, the tolerances shall be based on the diameter of the finished roller being the core diameter plus twice the cover thickness.

Cylindricity tolerances (see figure 2) for rollers of sufficient rigidity are specified in table 5. Tolerances for rollers of insufficient rigidity shall be agreed between the interested parties.

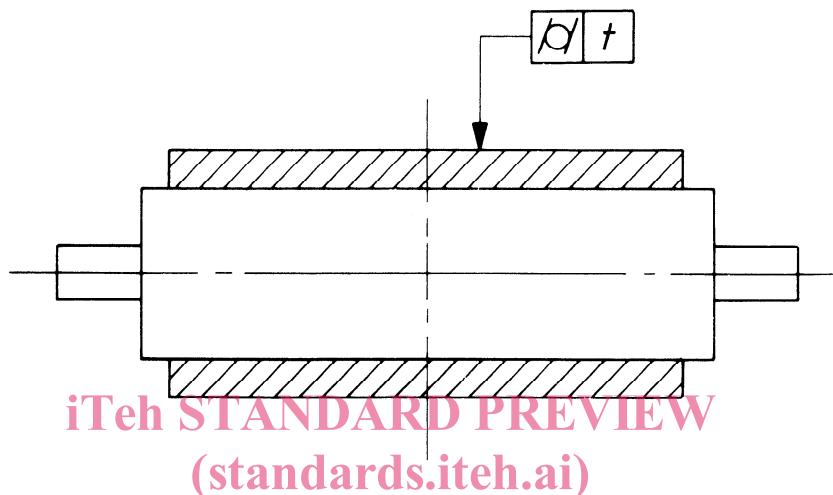

Figure 2 — Cylindricity tolerances

<https://standards.iteh.ai/catalog/standards/sist/d57bf98a-24d4-49d4-9fc0-7b77db66a66e/iso-6123-3-1985>

Table 5

Hardness		Class				
IRHD Shore A	Pusey and Jones				H	Q
< 50	> 120	—	—	—	H	Q
50 to 70	120 to 70	—	—	P	H	Q
> 70 to < 100	< 70 to 10	—	XP	P	H	Q
≈ 100	9 to 0	XXP	XP	P	H	Q
Nominal roller cover diameter (mm)		Cylindricity tolerance, t (mm)				
≤ 40		0,01	0,02	0,04	0,08	0,15
> 40 to < 63		0,02	0,03	0,06	0,10	0,19
> 63 to < 100		0,03	0,04	0,08	0,13	0,20
> 100 to < 160		0,03	0,05	0,10	0,17	0,25
> 160 to < 250		0,03	0,06	0,12	0,20	0,30
> 250 to < 400		0,04	0,07	0,14	0,23	0,35
> 400 to < 630		0,04	0,08	0,18	0,30	0,45
> 630		0,05	0,10	0,25	0,35	0,55

9.2 Crown tolerances

The permissible crown tolerance (see figure 3) shall be taken from classes in table 6.

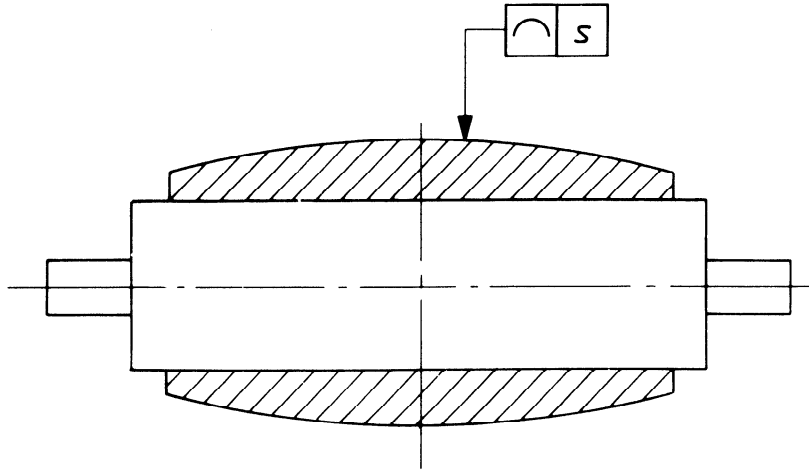

Figure 3 – Crown tolerances

iTeh STANDARD PREVIEW

Table 6

Values in millimetres

Nominal crown	Class	
	XP	P
	Crown profile tolerance, s	
< 0,10	0,04	0,06
> 0,10 to < 0,16	0,05	0,08
> 0,16 to < 0,25	0,06	0,10
> 0,25 to < 0,40	0,08	0,12
> 0,40 to < 0,63	0,10	0,16
> 0,63 to < 1,00	0,12	0,20
> 1,00 to < 1,60	0,16	0,30
> 1,60 to < 2,50	0,25	0,40
> 2,50 to < 4,00	0,40	0,60
> 4,00	10 %	— *

* P—tolerances for crowns above nominal dimension 4,00 shall be agreed between the interested parties and expressed as a percentage.