

4

INTERNATIONAL STANDARD

ISO 6124-1

Third edition
1987-11-15



INTERNATIONAL ORGANIZATION FOR STANDARDIZATION
ORGANISATION INTERNATIONALE DE NORMALISATION
МЕЖДУНАРОДНАЯ ОРГАНИЗАЦИЯ ПО СТАНДАРТИЗАЦИИ

Spherical plain radial bearings, joint type — Boundary dimensions —

Part 1: Dimension series E and G

STANDARD PREVIEW
(standards.iteh.ai)

Rotules lisses d'articulation à contact radial — Dimensions d'encombrement —

Partie 1: Séries de dimensions E et G

ISO 6124-1:1987

<https://standards.iteh.ai/catalog/standards/sist/ee1b2d99-1bcc-43d6-aaa6-e9ff4ca173e/iso-6124-1-1987>

Library / Библиотека
Do not remove / Не пас отлевер

Foreword

ISO (the International Organization for Standardization) is a worldwide federation of national standards bodies (ISO member bodies). The work of preparing International Standards is normally carried out through ISO technical committees. Each member body interested in a subject for which a technical committee has been established has the right to be represented on that committee. International organizations, governmental and non-governmental, in liaison with ISO, also take part in the work.

Draft International Standards adopted by the technical committees are circulated to the member bodies for approval before their acceptance as International Standards by the ISO Council. They are approved in accordance with ISO procedures requiring at least 75 % approval by the member bodies voting.

International Standard ISO 6124-1 was prepared by Technical Committee ISO/TC 4, *Rolling bearings*.

This third edition cancels and replaces the second edition (ISO 6124-1 : 1982), of which it constitutes a minor revision.

Users should note that all International Standards undergo revision from time to time and that any reference made herein to any other International Standard implies its latest edition, unless otherwise stated.

iTeh STANDARD PREVIEW
(standards.iteh.ai)

[ISO 6124-1:1987](https://standards.iteh.ai/catalog/standards/sist/ee1b2d99-1bcc-43d6-aaa6-e9ff4ca173e/iso-6124-1-1987)

[https://standards.iteh.ai/catalog/standards/sist/ee1b2d99-1bcc-43d6-aaa6-](https://standards.iteh.ai/catalog/standards/sist/ee1b2d99-1bcc-43d6-aaa6-e9ff4ca173e/iso-6124-1-1987)

[e9ff4ca173e/iso-6124-1-1987](https://standards.iteh.ai/catalog/standards/sist/ee1b2d99-1bcc-43d6-aaa6-e9ff4ca173e/iso-6124-1-1987)

Spherical plain radial bearings, joint type — Boundary dimensions —

Part 1: Dimension series E and G

iTeh STANDARD PREVIEW
(standards.iteh.ai)

1 Scope and field of application

This part of ISO 6124 specifies dimensions for spherical plain radial bearings, joint type, dimension series E and G.

These dimensions define the bearings geometrically but do not impose any restrictions as to material or manufacturing methods.

Chamfer dimension values are given as minimum values. Appropriate maximum values are the same as those specified in ISO 582 for rolling bearings.

Tolerances for the bore diameter, outside diameter and width are given in ISO 6125.

2 References

ISO 582, *Rolling bearings — Metric series — Chamfer dimension limits.*

ISO 6125, *Spherical plain radial bearings; joint type — Tolerances.*

3 Symbols

B	= inner ring width, nominal
C	= outer ring width, nominal
d	= bearing bore diameter, nominal
d_1	= outer diameter of inner ring face
D	= bearing outside diameter, nominal
r_1	= inner ring chamfer, height and width
r_2	= outer ring chamfer, height and width
$r_{1\text{min}}$	= smallest permissible single r_1
$r_{2\text{min}}$	= smallest permissible single r_2
α	= angle of permissible tilt

4 Dimensions

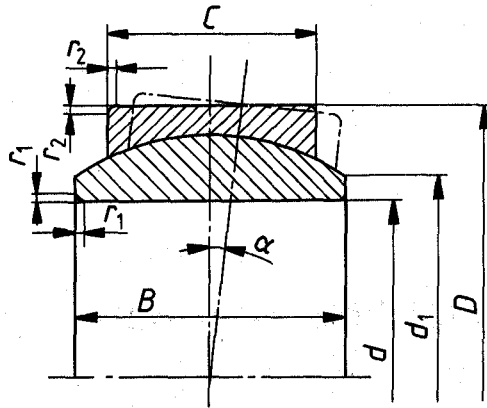

Table 1 — Series E

Dimensions in millimetres

d	D	B	C	d _{1min}	r _{1smin}	r _{2smin}	α ¹⁾
4	12	5	3	6	0,3	0,3	16°
5	14	6	4	7	0,3	0,3	13°
6	14	6	4	8	0,3	0,3	13°
8	16	8	5	10	0,3	0,3	15°
10	19	9	6	13	0,3	0,3	12°
12	22	10	7	15	0,3	0,3	10°
14	26	12	9	18	0,3	0,3	8°
15	26	12	9	18	0,3	0,3	8°
16	30	14	10	20	0,3	0,3	10°
17	30	14	10	20	0,3	0,3	10°
20	35	16	12	24	0,3	0,3	9°
24	42	20	16	29	0,6	0,6	7°
25	42	20	16	29	0,6	0,6	7°
30	47	22	18	34	0,6	0,6	6°
35	55	25	20	39	0,6	1	6°
40	62	28	22	45	0,6	1	7°
45	68	32	25	50	0,6	1	7°
50	75	35	28	55	0,6	1	6°
55	85	40	32	62	0,6	1	7°
60	90	44	36	66	1	1	6°
70	105	49	40	77	1	1	6°
80	120	55	45	88	1	1	6°
90	130	60	50	98	1	1	5°
100	150	70	55	109	1	1	7°
110	160	70	55	120	1	1	6°
120	180	85	70	130	1	1	6°
140	210	90	70	150	1	1	7°
160	230	105	80	170	1	1	8°
180	260	105	80	192	1,1	1,1	6°
200	290	130	100	212	1,1	1,1	7°
220	320	135	100	238	1,1	1,1	8°
240	340	140	100	265	1,1	1,1	8°
260	370	150	110	285	1,1	1,1	7°
280	400	155	120	310	1,1	1,1	6°
300	430	165	120	330	1,1	1,1	7°

1) Approximate values.

Table 2 — Series G

Dimensions in millimetres

d	D	B	C	d _{1min}	r _{1smin}	r _{2smin}	α ¹⁾
4	14	7	4	7	0,3	0,3	20°
5	16	9	5	8	0,3	0,3	21°
6	16	9	5	9	0,3	0,3	21°
8	19	11	6	11	0,3	0,3	21°
10	22	12	7	13	0,3	0,3	18°
12	26	15	9	16	0,3	0,3	18°
14	30	16	10	19	0,3	0,3	16°
15	30	16	10	19	0,3	0,3	16°
16	35	20	12	21	0,3	0,3	19°
17	35	20	12	21	0,3	0,3	19°
20	42	25	16	24	0,3	0,6	17°
24	47	28	18	29	0,6	0,6	17°
25	47	28	18	29	0,6	0,6	17°
30	55	32	20	34	0,6	1	17°
35	65	35	22	39	0,6	1	16°
40	68	40	25	44	0,6	1	17°
45	75	43	28	50	0,6	1	15°
50	90	56	36	57	0,6	1	17°
60	105	63	40	67	1	1	17°
70	120	70	45	77	1	1	16°
80	130	75	50	87	1	1	14°
90	150	85	55	98	1	1	15°
100	160	85	55	110	1	1	14°
110	180	100	70	122	1	1	12°
120	210	115	70	132	1	1	16°
140	230	130	80	151	1	1	16°
160	260	135	80	176	1	1,1	16°
180	290	155	100	196	1,1	1,1	14°
200	320	165	100	220	1,1	1,1	15°
220	340	175	100	243	1,1	1,1	16°
240	370	190	110	263	1,1	1,1	15°
260	400	205	120	285	1,1	1,1	15°
280	430	210	120	310	1,1	1,1	15°

1) Approximate values.

UDC 621.822.3

Descriptors : bearings, plain bearings, radial bearings, spherical bearings, dimensions.

Price based on 2 pages