

INTERNATIONAL STANDARD

ISO
6150

First edition
1988-04-15



INTERNATIONAL ORGANIZATION FOR STANDARDIZATION
ORGANISATION INTERNATIONALE DE NORMALISATION
МЕЖДУНАРОДНАЯ ОРГАНИЗАЦИЯ ПО СТАНДАРТИЗАЦИИ

Pneumatic fluid power — Cylindrical quick-action couplings for maximum working pressures of 10 bar, 16 bar and 25 bar (1 MPa, 1,6 MPa and 2,5 MPa) — Plug connecting dimensions, specifications, application guidelines and testing

(standards.iteh.ai)

Transmissions pneumatiques — Raccords rapides cylindriques pour pressions maximales d'utilisation 10 bar, 16 bar et 25 bar (1 MPa, 1,6 MPa et 2,5 MPa) — Dimensions de raccordement de la partie mâle, spécifications, conseils d'utilisation et essais

5322586ed060/iso-6150-1988

Reference number
ISO 6150:1988 (E)

Foreword

ISO (the International Organization for Standardization) is a worldwide federation of national standards bodies (ISO member bodies). The work of preparing International Standards is normally carried out through ISO technical committees. Each member body interested in a subject for which a technical committee has been established has the right to be represented on that committee. International organizations, governmental and non-governmental, in liaison with ISO, also take part in the work. ISO collaborates closely with the International Electrotechnical Commission (IEC) on all matters of electrotechnical standardization.

Draft International Standards adopted by the technical committees are circulated to the member bodies for approval before their acceptance as International Standards by the ISO Council. They are approved in accordance with ISO procedures requiring at least 75 % approval by the member bodies voting.

International Standard ISO 6150 was prepared by Technical Committee ISO/TC 131, *Fluid power systems*.

[ISO 6150:1988](#)

Users should note that all International Standards undergo revision from time to time and that any reference made herein to any other International Standard implies its latest edition, unless otherwise stated.

Pneumatic fluid power — Cylindrical quick-action couplings for maximum working pressures of 10 bar, 16 bar and 25 bar (1 MPa, 1,6 MPa and 2,5 MPa) — Plug connecting dimensions, specifications, application guidelines and testing

0 Introduction

In pneumatic fluid power systems, power is transmitted and controlled through gas under pressure within a circuit.

Quick-action couplings are used to join or separate fluid conducting lines quickly without the use of tools or special devices.

1 Scope and field of application

This International Standard lays down the dimensions and tolerances so as to ensure the interchangeability of pneumatic quick-action coupling plugs. It also lays down specifications and application guidelines, and specifies the tests to be applied to the plugs together with sockets.

NOTE — The construction and dimensions of sockets are left to the manufacturer's option.

This International Standard applies to cylindrical quick-action couplings for maximum working pressures of 10 bar¹⁾, 16 bar and 25 bar (1 MPa, 1,6 MPa and 2,5 MPa) for use in pneumatic fluid power systems.

NOTE — Quick-action couplings with shut-off valves for equipment for welding, cutting and related processes are covered by ISO 7289, *Quick-action couplings with shut-off valve for welding, cutting and allied processes*.²⁾

This International Standard applies only to the dimensional criteria of products manufactured in accordance with this International Standard. It does not apply to their functional characteristics.

2 References

ISO 3768, *Metallic coatings — Neutral salt spray test (NSS test)*.

ISO 4399, *Fluid power systems and components — Connectors and associated components — Nominal pressures*.

ISO 4414, *Pneumatic fluid power — Recommendations for the application of equipment to transmission and control systems*.

ISO 5598, *Fluid power systems and components — Vocabulary*.

3 Definitions

For the purposes of this International Standard, the definitions given in ISO 5598 and the following definition apply.

maximum working pressure: The maximum pressure at the coupling in a system.

4 Dimensions and tolerances

4.1 Cylindrical quick-action couplings for pneumatic fluid power systems are classified according to their maximum working pressure into the following three different series:

- **Series A:** Cylindrical quick-action couplings for a maximum working pressure of 10 bar (1 MPa).
- **Series B:** Cylindrical quick-action couplings for a maximum working pressure of 16 bar (1,6 MPa).
- **Series C:** Cylindrical quick-action couplings for a maximum working pressure of 25 bar (2,5 MPa).

4.2 Tables 1 to 3 and figures 1 to 3 are only concerned with the dimensions and tolerances of the plug. The socket is left to the manufacturer's option; the same condition applies to the plug end for connection to either a component, or a pipe or hose.

1) 1 bar = 0,1 MPa = 10⁵ Pa; 1 Pa = 1 N/m²

2) At present at the stage of draft.

4.2.1 The dimensions and tolerances for plugs on series A cylindrical quick-action couplings are shown in figure 1 and given in table 1.

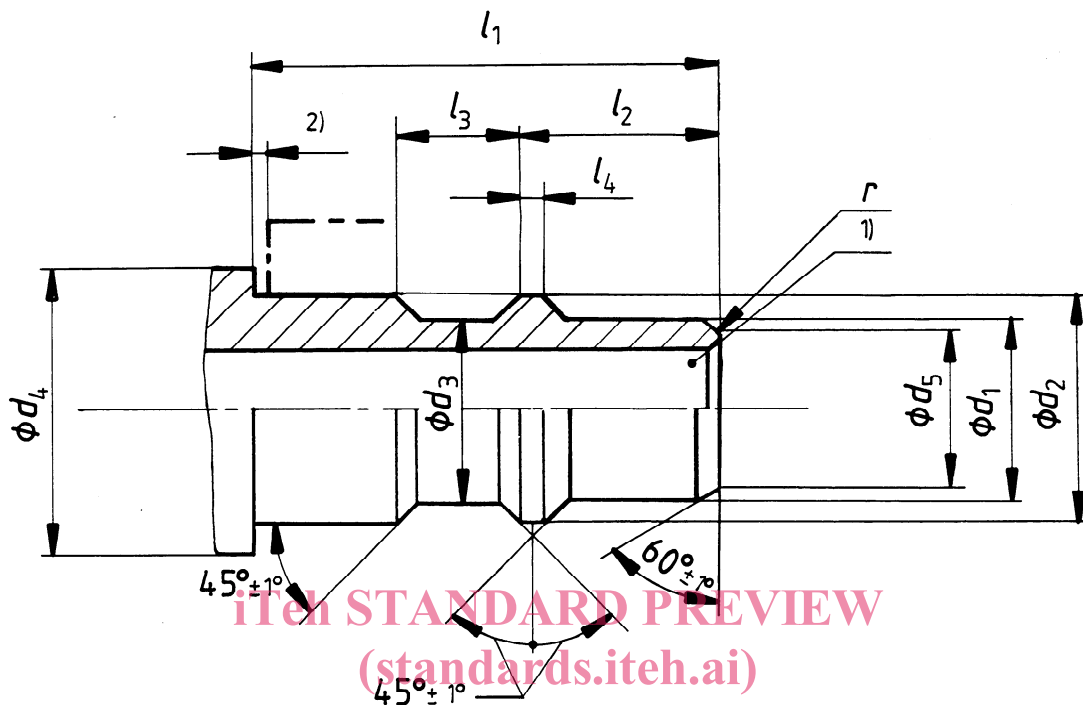

Figure 1 — Plug for 10 bar (1 MPa) maximum working pressure (series A)

Table 1 — Dimensions for plug for 10 bar (1 MPa) maximum working pressure (series A)

Dimensions in millimetres

Nominal diameter	d_1 h11	d_2 d11	d_3	$d_4^{3)}$ min.	d_5	l_1 $+0,2$ 0	l_2	l_3	l_4	r
6	4,5	6	4,5	11	3,9	16	$7 +0,2$ 0	$3 +0,15$ 0	0,5	0,2 to 0,3
10	8	10	8	15	7	20	$8,5 +0,3$ 0	$5,5 +0,2$ 0	1	0,3 to 0,5
13	11	13	11	18	10	21				
15	13	15	13	20	12	24				
18	16	18	16	23	15	27				

1) Inside diameter as large as possible.

2) The distance between the shoulder of the plug and the end surface of the socket, when connected, shall not exceed 1 mm.

3) Minimum actual diameter.

4.2.2 The dimensions and tolerances for plugs on series B cylindrical quick-action couplings are shown in figure 2 and given in table 2.

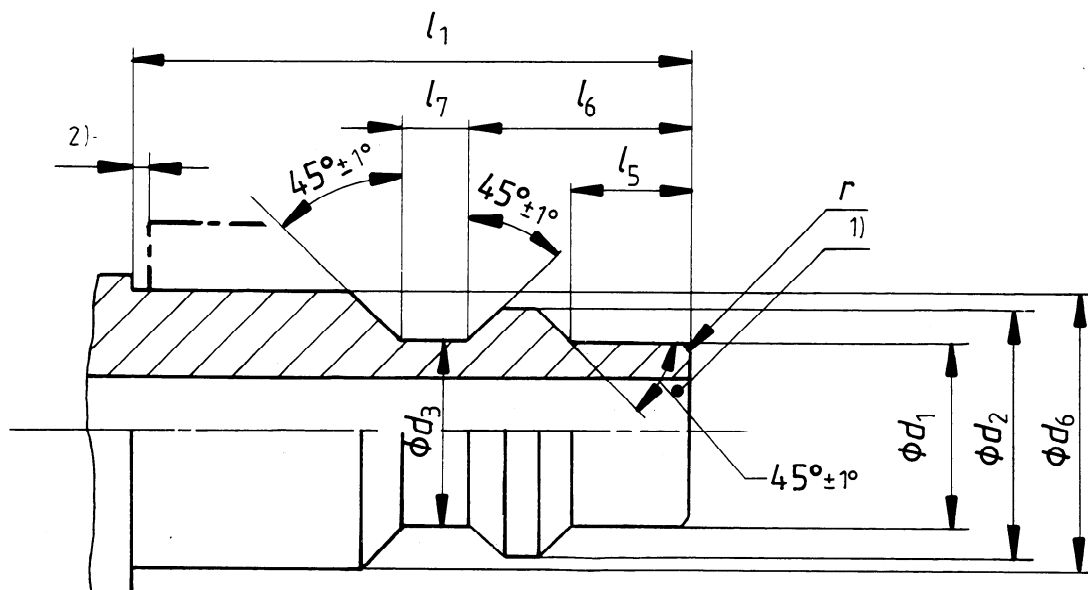

Figure 2 — Plug for 16 bar (1.6 MPa) maximum working pressure (series B)
 (standards.iteh.ai)

Table 2 — Dimensions for plug for 16 bar (1.6 MPa) maximum working pressure (series B)

<https://standards.iteh.ai/catalog/standards/sist/444bcc5d-22ae-4bd3-95ch-5322586ed090/iso-6150-1988>

Dimensions in millimetres

Nominal diameter	d_1 -0,1 -0,2	d_2 -0,1 -0,2	d_3 -0,05 -0,15	d_6 -0,1 -0,2	l_1 min.	l_5 +0,10 -0,15	l_6 +0,10 -0,15	l_7 +0,10 -0,15	r +0,10 -0,15
7	4,55	6,5	4,45	7	20	5	8	2,5	0,4
12	8,2	11	7,9	11,9	23,6	5,4	9,4	2,8	
15	11	14,4	11,6	15,2	26,1	7,65	12,3	2,6	1
17	14,4	16,8	14,3	16,8	34,8	9,55	14,7	2,8	0,4
23	20,55	23	20,45	23	35	6,5	10,7	3	1

1) Inside diameter as large as possible; break corner at 0,5 mm max. Test that the flow characteristics of the male part provide sufficient air flow and strength at the male part.

2) The distance between the shoulder of the plug and the end surface of the socket, when connected, shall not exceed 1 mm.

4.2.3 The dimensions and tolerances for plugs on series C cylindrical quick-action couplings are shown in figure 3 and given in table 3.

Dimensions in millimetres

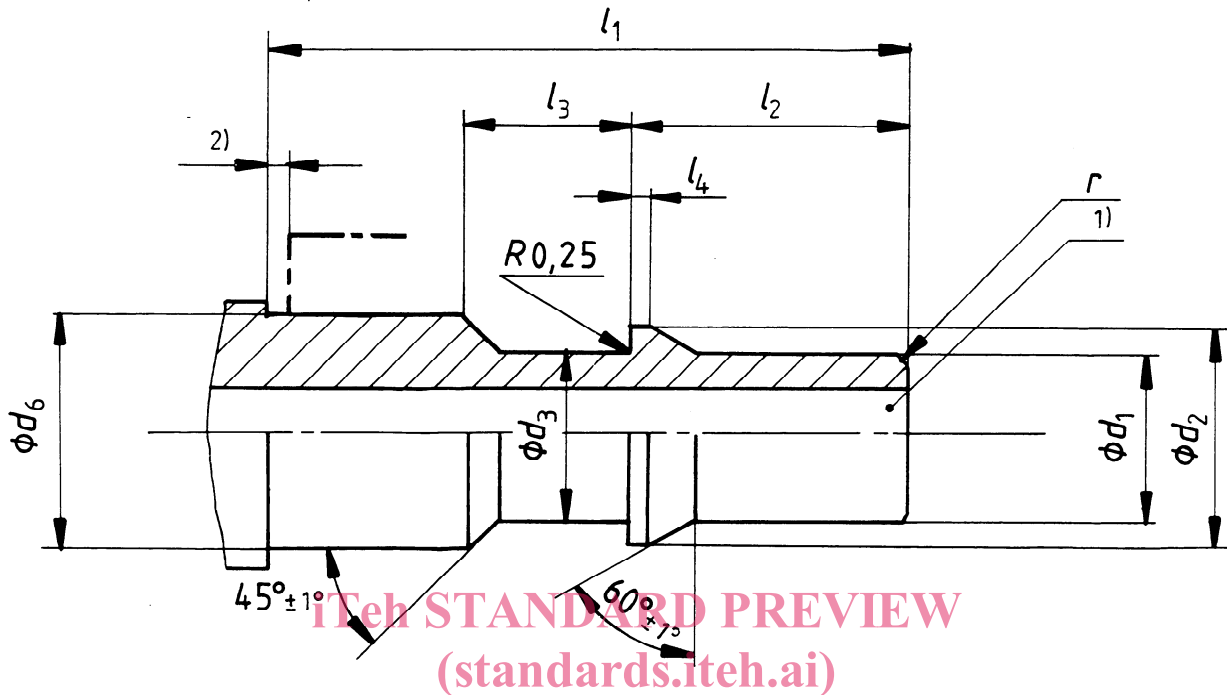

Figure 3 — Plug for 25 bar (2,5 MPa) maximum working pressure (series C)

ISO 6150:1988

<https://standards.iteh.ai/catalog/standards/sist/444bcc5d-22ae-4bd3-95cb->

Table 3 — Dimensions for plug for 25 bar (2,5 MPa) maximum working pressure (series C)

Dimensions in millimetres

Nominal diameter	d_1 f8	d_2 js11	d_3 $\pm 0,15$	d_3 f8	l_1 min.	l_2 $\pm 0,1$	l_3 JS13	l_4 $\pm 0,1$	r max.
8	5	7,4	5	7,5	25	10	4,5	0,7	0,3
10	7,5	9,7	7,4	10	27,5	12	7	0,75	1
14	11	13,7	11	14	36,5	17	9,5	1,5	
17	14	16,7	14	17	41	18	12,5	2	
27	23	26,7	23	27	61	27	16	2,5	2

1) Inside diameter as large as possible.

2) The distance between the shoulder of the plug and the end surface of the socket, when connected, shall not exceed 1 mm.

5 Designation

The designation for a quick-action coupling in accordance with this International Standard shall include, in the order given, the following information:

- a) identity block, i.e. the word "Coupling";
- b) the reference to this International Standard;
- c) the letter standing for the series of coupling (i.e. A, B or C);
- d) the nominal diameter.

Example:

A cylindrical quick-action coupling for maximum working pressure of 16 bar (1,6 MPa), i.e. series B, and having a nominal diameter of 15 mm shall be designated as follows:

Coupling ISO 6150-B-15

6 Requirements

6.1 Material

The choice of the material is left to the discretion of the manufacturer who shall take account of the intended application.

6.2 Hardness

The plug shall have a hardness suitable for applications as recommended by the manufacturer.

6.3 Surface finish

The surface finish of the plug shall be left to the manufacturer's option, but the surface roughness, R_a , of the sealing surface as defined in figure 4 shall be $3,2 \mu\text{m}$ max.

NOTE — The requirements for the surface finish of the coupling plug in contact with the seal are dependent on the application and the life-time requirements; any such requirements should be subject to agreement between the manufacturer and user.

6.4 Corrosion protection

The quick-action coupling plug shall meet the requirements for the tests described in 8.4.

6.5 Number of couplings and uncouplings

After completing 5 000 coupling and uncoupling cycles at maximum working pressure, quick-action couplings shall still meet the requirements specified by the manufacturer.

6.6 Test pressures

6.6.1 Quick-action couplings shall be usable after they have been subjected to a pressure test, as described in 8.3, at 1,5 times the maximum working pressure.

6.6.2 Quick-action couplings shall be designed to withstand four times the maximum working pressure.

6.7 Tests at extreme working temperatures

6.7.1 Subject couplings, in accordance with the procedure described in 8.6.4, to the manufacturer's recommended constant extreme operating temperatures in both positions, coupled and uncoupled.

- for 6 h at maximum working temperature, in each position;
- for 4 h at minimum working temperature, in each position.

6.7.2 Record any signs of leakage, deformation or malfunction.

6.8 Limited rotation for self-alignment

The male plug and female socket shall be such that, when subjected to maximum working pressure, the downstream hose or tool may rotate for alignment to prevent torque loading of the hose or coupling.

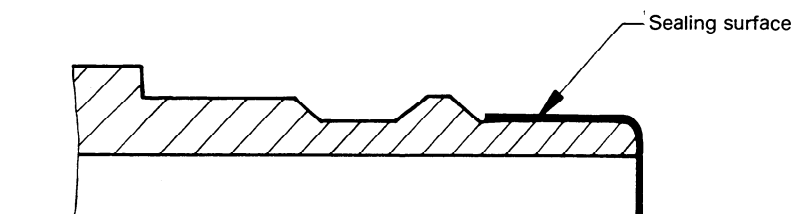

Figure 4 — Definition of sealing surface

6.9 Structural rigidity

Coupled quick-action couplings shall withstand

- a) a radial load of 2 200 N;
- b) an axial load of 2 200 N.

NOTE — For couplings made of plastic materials, the load should be limited to 440 N.

6.10 Leakage

The coupled quick-action coupling or the female socket only shall have leakage which does not exceed the value indicated by the manufacturer at maximum working pressure.

This requirement shall be verified in accordance with the procedure described in 8.6.3.

7 Application guidelines

7.1 Installation with vibrating tools

It is recommended that a minimum length of 300 mm of flexible hose for compressed air be inserted between a vibrating tool and the quick-action coupling.

7.2 Coupling and uncoupling safety considerations

Attention of the circuit designer and/or user is drawn to the fact that a decompression system should be provided to increase safety when coupling or uncoupling (see ISO 4414), for example

- to avoid the plug being forced out dangerously due to pressure;
- to avoid compressed air or particulate matter being expelled dangerously;
- to allow coupling and uncoupling at safe pressure levels.

8 Testing

The test procedures described in this clause apply to the quick-action coupling plug, manufactured in accordance with this International Standard, together with the socket.

The test procedures described are intended for "type-testing" quick-action couplings.

The test methods and diagrams of the test set-ups as shown in figures 5 to 11 are given for illustration purposes and do not form part of the requirements.

8.1 Accuracy of test equipment and instrumentation

The accuracy of the test equipment and instrumentation shall be selected, set and maintained within the limits specified in table 4.

Table 4 — Accuracy of test equipment and instrumentation

Parameter	Unit	Accuracy
Temperature	°C	± 5 °C
Leakage	mm ³	± 2 %
Side load	N	± 2 %
Pressure	bar (MPa)	± 2 %
Flow rate	l/s	± 2 %

8.2 Checking of compliance

8.2.1 Examine each type component carefully to see that it complies with the manufacturer's drawings, catalogue sheets and with tables 1 to 3 of this International Standard.

8.2.2 Mark each component permanently in a manner which will not interfere with its normal operation, but will enable it to be related to each appropriate test procedure and/or report.

8.2.3 Measure and record the actual sizes of the standardized dimensions of the components for possible use in a test report.

Carry out measurements at a temperature of 20 °C.

8.3 Hydraulic test

8.3.1 The quick-action coupling plug shall be matched and coupled with the corresponding socket.

8.3.2 Couple the female socket to a hydraulic pressure source.

8.3.3 Block the open end of the male plug.

8.3.4 Raise the pressure within the coupling assembly to four times the manufacturer's recommended working pressure.

NOTE — No rupture or permanent deformation should occur after 1 min of test.

8.4 Corrosion test

8.4.1 Only the plug of the coupling shall be subjected to this test which shall be performed in accordance with ISO 3768.

8.4.2 Carry out the tests for 24 h. The results of the tests shall be declared acceptable if, on completion of the test duration, no sign of corrosion is observed on outside surfaces after surface corrosion products have been removed.

8.5 Test for structural rigidity

8.5.1 Submit the coupled coupling to the radial load specified in 6.9, the load being applied to the actuating sleeve or main part of the coupling body in a test set-up as shown in figure 10. After 1 min, no deformation or failure shall be noted.

NOTE — This test is intended to simulate an accidental radial load, e.g. a truck running over a coupling.

8.5.2 Submit the coupled coupling to the axial load specified in 6.9, the load being applied directly to the plug inserted in the socket as shown in figure 11.

During testing, the plug or socket shall not uncouple, deform or fail.

Furthermore, after this test, the coupling shall be submitted to a leakage test as described in 8.6.3. No leak shall be observed.

8.6 Operational tests

Carry out the test on quick-action couplings lightly lubricated with an approved lubricant compatible with the seal material.

8.6.1 Disconnect force

8.6.1.1 Insert the coupling assembly in an appropriate test fixture (see figure 5).

8.6.1.2 Maintain the manufacturer's recommended working pressure as test pressure.

8.6.1.3 Apply a force and/or torque to the locking mechanism until the assembly disconnects.

8.6.1.4 Measure the force and/or torque needed to disconnect the coupling assembly.

8.6.1.5 Repeat the test five times within a 10 min period. Leave coupled for 1 h, then disconnect, check and note the force and/or torque for this uncoupling and the average disconnect force for the first five tests.

8.6.1.6 Record any sign of flow blocking, damage or malfunction.

8.6.2 Connect force

8.6.2.1 Insert the coupling in an appropriate test fixture (see figure 6).

8.6.2.2 Maintain the manufacturer's recommended working pressure as test pressure.

8.6.2.3 Apply a force and/or torque to the plug until the plug is fully connected.

NOTE — During this operation, the locking mechanism may be operated manually, if necessary, so that both halves can be coupled normally.

8.6.2.4 Measure the force and/or torque needed to connect the coupling assembly.

8.6.2.5 Repeat the test five times within a 10 min period.

8.6.2.6 Average the results of the five tests to determine the connect force and/or torque.

8.6.2.7 Record any sign of flow blocking, damage or malfunction.

8.6.3 Measurement of leakage at maximum working pressure

8.6.3.1 Uncoupled

8.6.3.1.1 Install the valved socket in the test container as shown in figure 7.

8.6.3.1.2 Hold the inverted graduated cylinder over the coupling with the mouth below the surface.

8.6.3.1.3 Maintain the maximum working pressure as test pressure.

8.6.3.1.4 Measure and record leakage within the accuracy limits specified in table 4 by collecting, for example, the escaped air with an inverted graduated cylinder.

8.6.3.1.5 Measure the volume of air when the fluid levels inside and outside the graduated container coincide.

8.6.3.2 Coupled

8.6.3.2.1 Install the coupling in the test container as shown in figure 7.

8.6.3.2.2 Apply a side load of 40 N as shown in figure 8.

8.6.3.2.3 Maintain the maximum working pressure for 5 min.

8.6.3.2.4 Measure and record leakage as specified in 8.6.3.1.5.

8.6.4 Extreme temperature test at maximum working pressure

8.6.4.1 Maximum operating temperature, uncoupled

8.6.4.1.1 Use a test set-up similar to that shown in figure 9.

8.6.4.1.2 Subject the socket to the manufacturer's recommended maximum constant temperature and pressure for 6 h.

8.6.4.1.3 Let the temperature return to ambient (without pressure).

8.6.4.1.4 Determine leakage as specified in 8.6.3.1.

8.6.4.2 Maximum operating temperature, coupled

8.6.4.2.1 Use a test set-up similar to that shown in figure 9.

iTeh STANDARD PREVIEW
(standards.iteh.ai)

ISO 6150:1988

<https://standards.iteh.ai/catalog/standards/sist/444bccc5d-22ac-4bd3-95cb-5372581a1860/iso-6150-1988>