

INTERNATIONAL STANDARD

ISO
6157-1

First edition
1988-08-01



INTERNATIONAL ORGANIZATION FOR STANDARDIZATION
ORGANISATION INTERNATIONALE DE NORMALISATION
МЕЖДУНАРОДНАЯ ОРГАНИЗАЦИЯ ПО СТАНДАРТИЗАЦИИ

Fasteners — Surface discontinuities —

Part 1:

Bolts, screws and studs for general requirements

iteh STANDARD PREVIEW

(standards.iteh.ai)

Éléments de fixation — Défauts de surface —

Partie 1: Boulons, vis et goujons d'usage général 6157-1:1988

<https://standards.iteh.ai/catalog/standards/sist/3c110000-825e-4706-a9b5-3e8672f193c3/iso-6157-1-1988>

Reference number
ISO 6157-1:1988 (E)

Foreword

ISO (the International Organization for Standardization) is a worldwide federation of national standards bodies (ISO member bodies). The work of preparing International Standards is normally carried out through ISO technical committees. Each member body interested in a subject for which a technical committee has been established has the right to be represented on that committee. International organizations, governmental and non-governmental, in liaison with ISO, also take part in the work. ISO collaborates closely with the International Electrotechnical Commission (IEC) on all matters of electrotechnical standardization.

Draft International Standards adopted by the technical committees are circulated to the member bodies for approval before their acceptance as International Standards by the ISO Council. They are approved in accordance with ISO procedures requiring at least 75 % approval by the member bodies voting.

International Standard ISO 6157-1 was prepared by Technical Committee ISO/TC 2, *Fasteners*.

[ISO 6157-1:1988](#)

<https://standards.iteh.ai/catalog/standards/sist/3c110000-825e-4706-a9b5-ec0211391c06/iso-6157-1-1988>

Users should note that all International Standards undergo revision from time to time and that any reference made herein to any other International Standard implies its latest edition, unless otherwise stated.

Fasteners — Surface discontinuities —

Part 1 : Bolts, screws and studs for general requirements

iTeh STANDARD PREVIEW (standards.iteh.ai)

1 Scope and field of application

1.1 This part of ISO 6157 establishes limits for various types of surface discontinuities on bolts, screws and studs for general requirements.

It applies to bolts, screws and studs with

- nominal thread diameters 5 mm and larger;
- product grades A and B;
- property classes up to and including 10.9, unless otherwise specified in product standards or agreed between supplier and purchaser.

1.2 Limits for surface discontinuities on bolts, screws and studs for special requirements (e.g. automatic assembly) are laid down in ISO 6157-3. When the engineering requirements of the application necessitate that surface discontinuities on bolts, screws and studs be more closely controlled, it should be specified in the respective product standard, or the purchaser shall specify the applicable limits in the inquiry and purchase order.

1.3 Where the permissible limits for surface discontinuities indicated in clause 3 occur, the minimum values for the mechanical and functional properties specified in ISO 898-1 should still be met.

NOTES

1 The figures in clause 3 are examples only. They apply correspondingly also to other types of bolts, screws and studs.

2 The individual figures show the surface discontinuities exaggerated in some cases for clarity.

2 References

ISO 468, *Surface roughness — Parameters, their values and general rules for specifying requirements.*

ISO 898-1, *Mechanical properties of fasteners — Part 1: Bolts, screws and studs.*

ISO 2859, *Sampling procedures and tables for inspection by attributes.*

ISO 3269, *Fasteners — Acceptance inspection.*

3 Types, causes, appearance and limits of surface discontinuities

3.1 Cracks

A crack is a clean (crystalline) fracture passing through or across the grain boundaries and may possibly follow inclusions of foreign elements. Cracks are normally caused by overstressing the metal during forging or other forming operations, or during heat treatment. Where parts are subjected to significant reheating, cracks usually are discoloured by scale.

3.1.1 Quench cracks

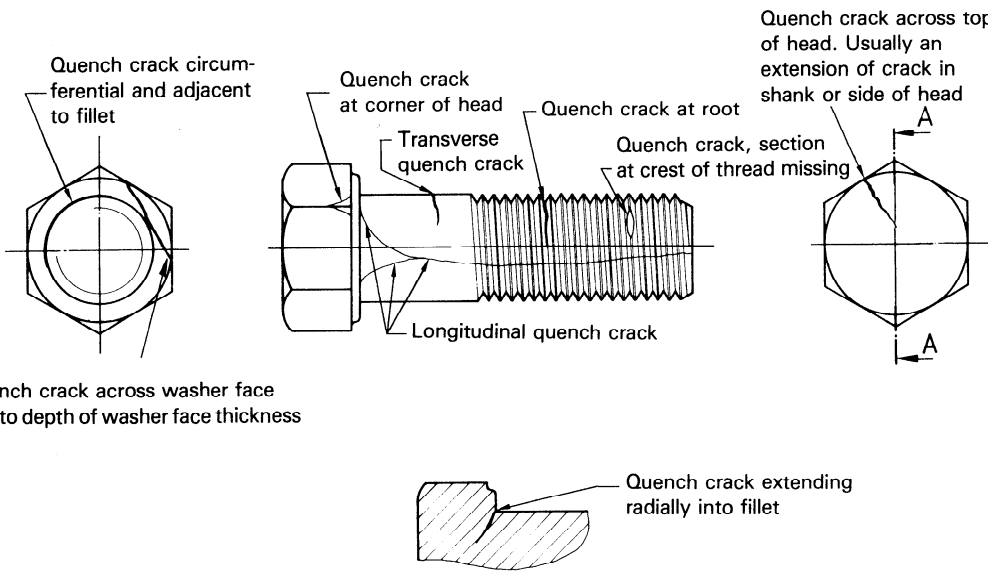
Cause	Quench cracks may occur during hardening due to excessively high thermal and transformation stresses. Quench cracks usually follow an irregular and erratic course on the surface of the fastener.
Appearance	 <p>Quench crack circumferential and adjacent to fillet</p> <p>Quench crack at corner of head</p> <p>Transverse quench crack</p> <p>Quench crack at root</p> <p>Quench crack, section at crest of thread missing</p> <p>Longitudinal quench crack</p> <p>Quench crack across washer face and to depth of washer face thickness</p> <p>Quench crack extending radially into fillet</p> <p>A-A</p> <p>Quench crack, at root</p> <p>Quench crack</p> <p>ISO 6157-1:1988 https://standards.iteh.ai/catalog/standards/sist/3c110000-825e-4706-a9b5-3e8672503c38/iso-6157-1-1988</p>
Limits	Quench cracks of any depth, any length, or in any location are not permitted.

3.1.2 Forging cracks

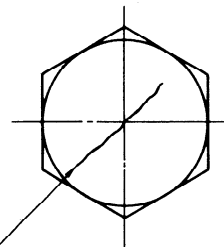
Cause	Forging cracks may occur during the cut-off or forging operations and are located on the top of the head of screws and bolts and on the raised periphery of indented head bolts and screws.
Appearance	 <p>Forging crack on top of head</p>
Limits	<p>Length, l, of forging cracks : $l < d^{1)}$</p> <p>Depth or width, b, of forging cracks : $b < 0,04d$</p> <p>1) d = nominal thread diameter</p>

3.1.3 Forging bursts

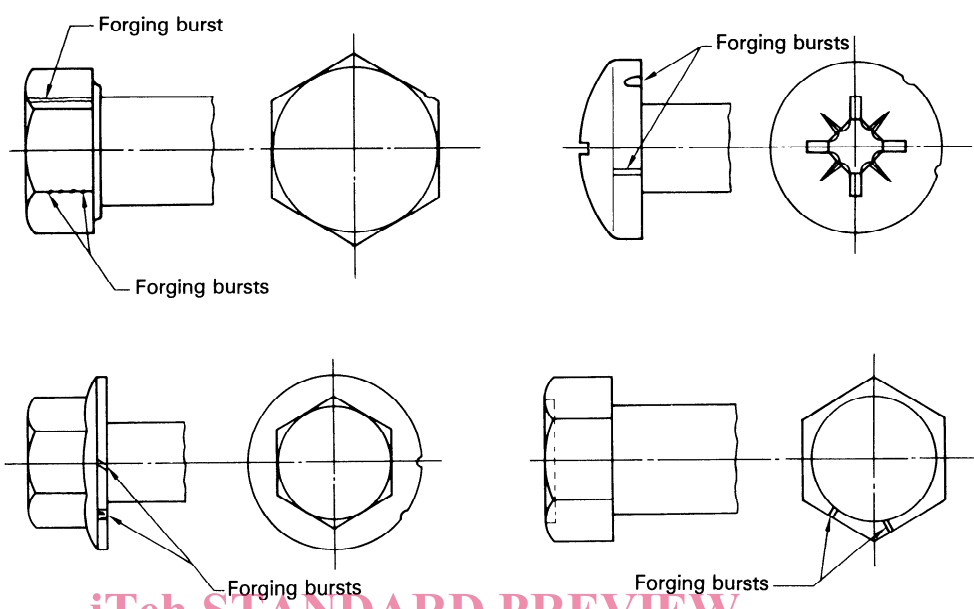
<p>Cause</p>	<p>Forging bursts may occur for example during forging on the flats or corners of the heads of bolts and screws, at the periphery of flanged or circular head products or on the raised periphery of indented head bolts and screws.</p>
<p>Appearance</p>	
<p>Limits</p>	<p>Hexagon head screws (standards.iteh.ai)</p> <p>No forging burst in the flats of hexagon bolts and screws shall extend into the crown circle on the top of the head surface (chamfer circle) or into the underhead bearing surface. Forging bursts occurring at the intersection of two wrenching flats shall not reduce the width across corners below the specified minimum.</p> <p>Forging bursts in the raised periphery of indented head bolts and screws shall not exceed a width of $0,06d^{1)}$ or have a depth extending below the indented portion.</p> <p>Circular head screws</p> <p>Flanges of bolts and screws and peripheries of circular head screws may have forging bursts, but they shall not exceed the following limits:</p> <p>Width of forging bursts:</p> <p>$0,08d_c^{2)}$ (with only one forging burst);</p> <p>$0,04d_c$ (with two or more forging bursts, one of which may extend to $0,08d_c$).</p> <p>1) d = nominal thread diameter 2) d_c = head or flange diameter</p>

3.1.4 Shear bursts

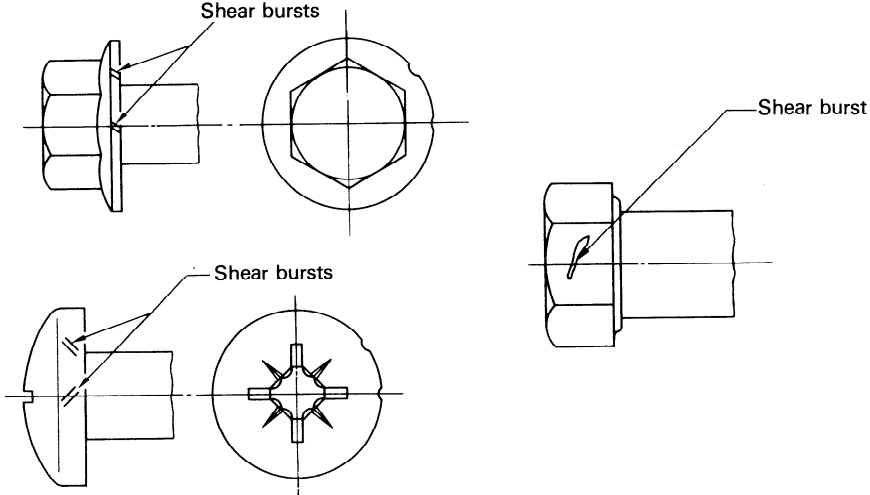
<p>Cause</p>	<p>Shear bursts may occur, for example during forging, frequently at the periphery of products having circular or flanged heads, and are located at approximately 45° to the product axis.</p> <p>Shear bursts may also occur on the sides of hexagon head products.</p>
<p>Appearance</p>	
<p>Limits</p>	<p>Hexagon head screws</p> <p>No shear burst in the flats of hexagon bolts and screws shall extend into the crown circle on the top of the head surface (chamfer circle) or into the underhead bearing surface. Shear bursts, occurring at the intersection of two wrenching flats, shall not reduce the width across corners below the specified minimum.</p> <p>Shear bursts in the raised periphery of indented head bolts and screws shall not exceed a width of $0,06d^{(1)}$ or have a depth extending below the indented portion.</p> <p>Circular head screws</p> <p>Flanges of bolts and screws and peripheries of circular head products may have shear bursts, but shall not exceed the following limits :</p> <p>Width of shear bursts :</p> <p>$0,08d_c^{(2)}$ (for only one shear burst);</p> <p>$0,04d_c$ (with two or more forging shear bursts, one of which may extend to $0,08d_c$).</p> <p>1) d = nominal thread diameter 2) d_c = head or flange diameter</p>

3.2 Raw material seams and laps

A seam or lap is a narrow, generally straight or smooth curved line discontinuity running longitudinally on the thread, shank or head.

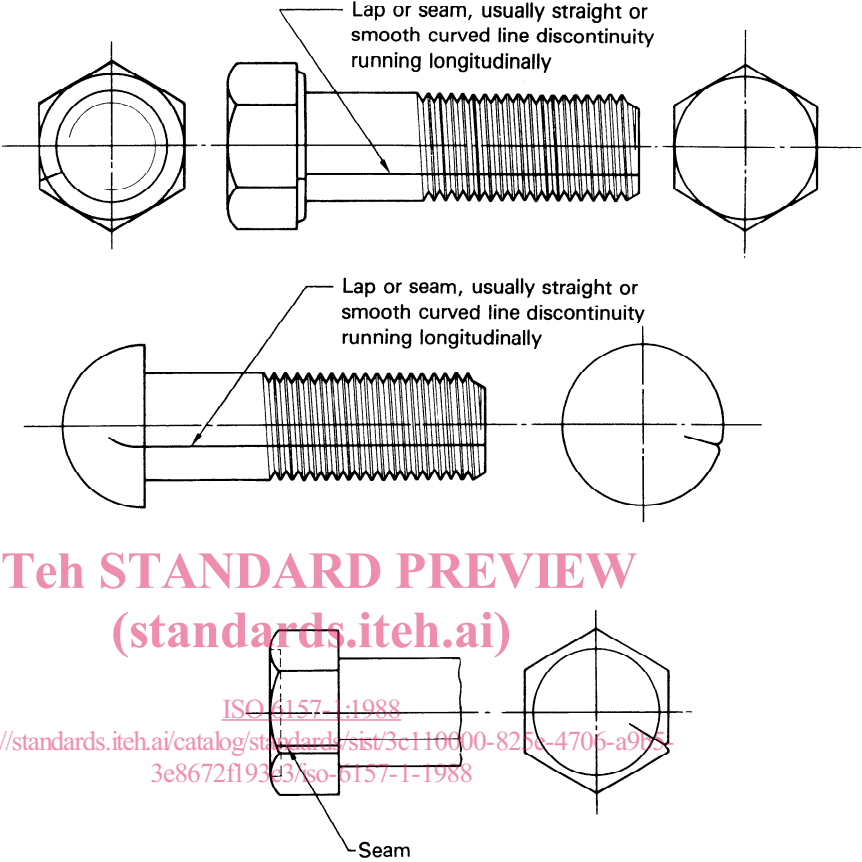
<p>Cause</p>	<p>Seams and laps are inherent in the raw material from which fasteners are made.</p>
<p>Appearance</p>	 <p>Lap or seam, usually straight or smooth curved line discontinuity running longitudinally</p> <p>Lap or seam, usually straight or smooth curved line discontinuity running longitudinally</p> <p>iTeh STANDARD PREVIEW (standards.iteh.ai)</p> <p>ISO 6157-1:1988 https://standards.iteh.ai/catalog/standards/sist/3c110600-8258-4706-a917-3e8672f19343/iso-6157-1-1988</p> <p>Seam</p>
<p>Limits</p>	<p>Permissible depth : $0,03d^{1)}$</p> <p>If laps or seams extend into the head, they shall not exceed the permissible limits for width and depth specified for bursts (see 3.1.3).</p> <p>1) d = nominal thread diameter</p>

3.3 Voids

A void is a shallow pocket or hollow on the surface of a bolt or screw due to non-filling of metal during forging or upsetting.

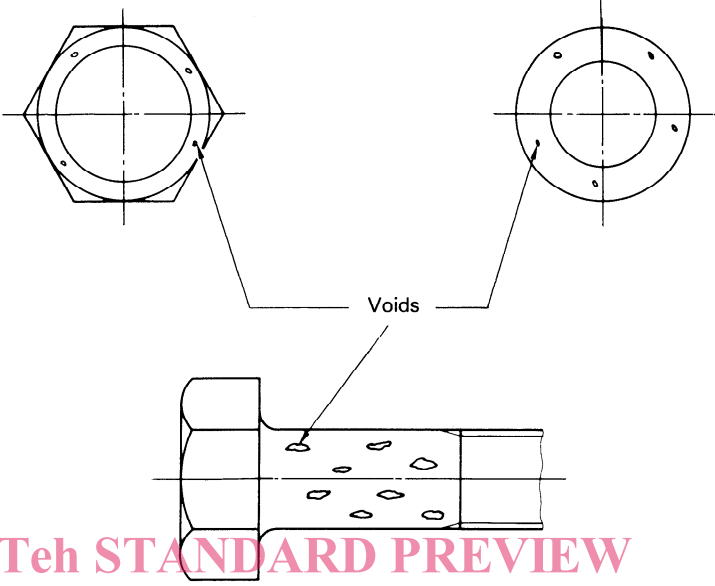
Cause	Voids are produced by marks and impressions due to chips (shear burrs) or by rust formation on the raw material. They are not eliminated during forging or upsetting operations.
Appearance	 <p style="text-align: center;">Voids</p> <p style="text-align: center;">iTeh STANDARD PREVIEW (standards.iteh.ai)</p>
Limits	<p>Depth, h, of voids:</p> <p style="text-align: center;">ISO 6157-1:1988</p> <p>$h < 0,02 d^1)$, 0,25 mm max.</p> <p>Area of all voids:</p> <p>The combined surface area of all voids on the bearing face shall not exceed 10 % of the total area.</p> <p>1) d = nominal thread diameter</p>

3.4 Folds

A fold is a doubling over of metal which occurs at the surface of the fastener during forging.

<p>Cause</p>	<p>Folds are produced by material displacements due to lack of congruence of forms and volumes of the single forging steps.</p>
<p>Appearance</p>	<p>Permissible, typical "clover leaf" fold in non-circular shoulder fastener</p> <p>Permissible, at the intersection between flange and driving part</p> <p>Permissible, fold at exterior corner</p> <p>Not permissible, fold at interior corner</p> <p>Permissible, fold at exterior corner</p> <p>Not permissible, fold at interior corner</p> <p>Permissible, at the surface of the bolt end</p> <p>iTeh STANDARD PREVIEW (standards.iteh.ai)</p> <p>ISO 6157-1:1988 https://standards.iteh.ai/catalog/standards/sist/3c110000-825e-4706-a706-3e8672f193c3/iso-6157-1-1988</p>
<p>Limits</p>	<p>Folds at interior corners at or below the bearing surface are not permissible, unless specifically permitted in this part of ISO 6157 or in the product standard.</p> <p>Folds at exterior corners are permissible.</p>

3.5 Tool marks

Tool marks are longitudinal or circumferential grooves of shallow depth.

<p>Cause</p>	<p>Tool marks are produced by the movement of manufacturing tools over the surface of the bolt or screw.</p>
<p>Appearance</p>	<p>Tool mark</p> <p>Permissible tool mark from trimming operation</p>
<p>Limits</p>	<p>Tool marks produced by machining in the shank, fillet or bearing surface shall not exceed a surface roughness of $R_a = 3,2 \mu\text{m}$ when tested in accordance with ISO 468.</p>