



SLOVENSKI STANDARD

SIST ISO 6194-3:1997

01-februar-1997

Gredne ustnične tesnilke - 3. del: Skladiščenje, ravnanje in vgradnja

Rotary shaft lip type seals -- Part 3: Storage, handling and installation

Bagues d'étanchéité à lèvres pour arbres tournants -- Partie 3: Stockage, manipulation et montage

(standards.iteh.ai)

Ta slovenski standard je istoveten z: **ISO 6194-3:1988**

<https://standards.iteh.ai/catalog/standards/sist/235c2b4a-ed76-4807-8cc1-7e2afde59006/sist-iso-6194-3-1997>

ICS:

23.100.60	Filtri, tesnila in onesnaževanje tekočin	Filters, seals and contamination of fluids
-----------	--	--

SIST ISO 6194-3:1997

en

iTeh STANDARD PREVIEW
(standards.iteh.ai)

SIST ISO 6194-3:1997

<https://standards.iteh.ai/catalog/standards/sist/235c2b4a-ed76-4807-8cc1-7e2afde59006/sist-iso-6194-3-1997>

INTERNATIONAL STANDARD

ISO
6194-3

First edition
1988-11-01



INTERNATIONAL ORGANIZATION FOR STANDARDIZATION
ORGANISATION INTERNATIONALE DE NORMALISATION
МЕЖДУНАРОДНАЯ ОРГАНИЗАЦИЯ ПО СТАНДАРТИЗАЦИИ

Rotary shaft lip type seals —

Part 3 : Storage, handling and installation

iteh STANDARD PREVIEW
(standards.iteh.ai)

Bagues d'étanchéité à lèvres pour arbres tournants —

Partie 3 : Stockage, manipulation et montage

SIST ISO 6194-3:1997

<https://standards.iteh.ai/catalog/standards/sist/235c2b4a-ed76-4807-8cc1-7e2afde59006/sist-iso-6194-3-1997>

ISO 6194-3 : 1988 (E)**Foreword**

ISO (the International Organization for Standardization) is a worldwide federation of national standards bodies (ISO member bodies). The work of preparing International Standards is normally carried out through ISO technical committees. Each member body interested in a subject for which a technical committee has been established has the right to be represented on that committee. International organizations, governmental and non-governmental, in liaison with ISO, also take part in the work. ISO collaborates closely with the International Electrotechnical Commission (IEC) on all matters of electrotechnical standardization.

Draft International Standards adopted by the technical committees are circulated to the member bodies for approval before their acceptance as International Standards by the ISO Council. They are approved in accordance with ISO procedures requiring at least 75 % approval by the member bodies voting.

International Standard ISO 6194-3 was prepared by Technical Committee ISO/TC 131, *Fluid power systems*.

<https://standards.iteh.ai/catalog/standards/sist/235c2b4a-ed76-4807-8cc1-7e2c7b59006/sist/6194-3-1997>

Users should note that all International Standards undergo revision from time to time and that any reference made herein to any other International Standard implies its latest edition, unless otherwise stated.

Rotary shaft lip type seals —

Part 3 : Storage, handling and installation

0 Introduction

0.1 This International Standard on rotary shaft lip type seals will consist of the following parts :

Part 1 : Nominal dimensions and tolerances.

Part 2 : Terminology.

Part 3 : Storage, handling and installation.

Part 4 : Performance test procedures.

Part 5 : Identification of visual imperfections.

0.2 Lip type seals are used for retaining fluid or grease in equipment employing rotating shafts. In some instances, the shaft is stationary and the housing rotates. Sealing of a lip type seal with low differential pressure is normally a result of a designed interference fit between the shaft and the flexible sealing element, which is usually fitted with a garter spring. An interference fit between the outside surface of the seal and the housing bore surface retains the seal in the housing and prevents leakage at the outer diameter.

0.3 Careful storage, handling and proper installation of rotary shaft lip type seals are necessary to avoid hazards both prior to and during installation which would adversely affect service life.

1 Scope and field of application

This part of ISO 6194 gives lip seal users guidance on the careful storage, handling and proper installation of rotary shaft lip type seals; attention is drawn to the hazards involved and ways of avoiding them are pointed out.

This part of ISO 6194 covers the storage and handling of lip seals, including the installation process, from the time they are received by the user.

2 References

ISO 5598, *Fluid power systems and components — Vocabulary*.

ISO 6194-1, *Rotary shaft lip type seals — Nominal dimensions and tolerances*.

3 Definitions

For the purposes of this part of ISO 6194, the definitions given in ISO 5598 apply.

NOTE — Terminology specific to rotary shaft lip type seals will be dealt with in ISO 6194-2.

4 General storage

4.1 Rotary shaft lip type seals shall be stored with caution because the service life of bearings and/or other costly machined parts may depend on how well the lip seal performs. Hazards which may be encountered include :

- temperature (see 4.2);
- ozone (see 4.4);
- humidity (see 4.2);
- radioactive materials (see 4.5);
- fumes (see 4.5);
- insects (see 4.6);
- rodents (see 4.6);
- dust (see 4.7);
- grit (see 4.7);
- mechanical damage (see 4.7).

4.2 The storage area shall be kept cool (below 30 °C) with an average relative humidity of 40 % to 70 %.

4.3 Seals shall be stored on a "first in, first out" basis, since, even under ideal conditions, an unusually long shelf-life may cause deterioration of element materials.

4.4 To retard ozone ageing, seals shall be kept away from direct or reflected sunlight and electrical equipment that may generate ozone. Excessive heat and/or exposure to ozone can cause premature ageing of the seal element thus reducing service life. Excessive humidity will deteriorate some seal element materials as well as cause corrosive damage to metal cases and springs.

ISO 6194-3 : 1988 (E)

4.5 Seals shall be protected from radioactive materials and certain fumes which can also cause deterioration of the seal element.

4.6 Seals shall be protected from insects and rodents, some of whom thrive on rubber products.

4.7 Lip seals should preferably be stored in a place other than a work area to avoid possible mechanical damage by equipment or falling objects. A closed container will provide protection from mechanical damage, as well as from dust, grit and other contaminants.

4.8 When cartons of lip seals are stacked, care shall be taken to avoid damage to the bottom parts due to excessive weight.

5 Packaging

5.1 The product shall be protected from damage and foreign material en route from the manufacturer to the user and during storage.

NOTE — Several methods are used to package lip seals. Good commercial practice dictates that the best packaging is the least expensive which still affords the protection desired. This should be assessed and agreed upon between the vendor and customer for each part shipped.

5.2 During unpacking, care shall be exercised so as not to cut or tear the seal element with sharp instruments, such as knives, screwdrivers, etc., brought about by improperly unpacking bulk packs, roll packs, and individually wrapped or boxed packs.

5.3 Seals shall not be removed from their packaging until they are ready for installation; this will ensure protection and identification.

6 Handling of loose parts

6.1 After seals have been removed from their packaging, they shall be handled carefully to prevent damage prior to installation. It shall be borne in mind that seal lips are extremely vulnerable to damage and that the smallest nick can provide a potential leak path.

6.2 Seals shall never be threaded on wires or strings or be hung on nails or pegs. Mishandling seals in this way can lead to the lip being distorted or even cut.

6.3 Care shall be exercised when handling seals with metal outside surfaces which may damage other seals, especially if the metal edges come into contact with the rubber parts of adjacent seals.

6.4 The seal surfaces shall be free of grit, chips and other abrasives since lip seals which are dumped onto surfaces such as work benches, are subject to contamination; seals which have been prelubricated are particularly susceptible to this hazard.

6.5 If it becomes necessary to clean lip seals, the manufacturer shall be asked to recommend a suitable cleaning solution. These cleaning materials vary with the type of compound used for the seal element. Commonly used solvents include high-flash naphthas and fluorocarbon solvents.

Abrasive cleaners shall never be used on lip seals as they can remove rubber and metal, causing flat spots and operating deficiencies.

Solvents, corrosive liquids and chemical cleaners shall not be allowed to come into contact with lip seals; these materials may be absorbed by the seal element causing it to swell, disintegrate or otherwise lose its physical properties.

Improper solutions shall not be used which can also cause a breakdown in the rubber-to-metal bond between the element and case or damage the metal case and spring.

7 Seal installation

7.1 The seal shall be examined before installation to ensure that it is clean and undamaged.

7.2 The sealing lip shall be smeared with a suitable, clean lubricant. Seals used as dust excluders shall be packed with a compatible grease.

7.3 The sealing lip, normally, should face the fluid to be sealed.

NOTE — The installed squareness is a factor in the performance of a radial lip seal. Squareness is obtained by pressing the seal even with the front face of the bore or bottoming against the shoulder of the bore.

7.4 The end of the shaft and the mouth of the housing bore shall be provided with lead-in chamfers as specified in ISO 6194-1.

7.5 Installation tools, such as illustrated in figure 1, shall be used to press the seal into place.

7.6 The seal shall always be aligned with a machined surface whether the seal is installed even with the bore front or bottomed against a shoulder (see figures 2 and 3). Unfinished surfaces cannot be used because of the danger of misalignment of the seal. Care shall be taken not to deform the seal case by applying excessive pressure.

7.7 Methods of installing a seal into a housing with the seal reversed are illustrated in figures 4a) to 4c).

7.8 Any surfaces over which the seal lip has to slide during installation shall be smooth and free from rough spots.

7.9 Special installation tools (see figure 5) shall be used to prevent seal lip damage if the seal element slides over splines, keyways or holes.

Tools of this type shall not be allowed to become nicked otherwise they will cause lip damage themselves.

Soft metals such as aluminium shall never be used since they nick very easily.

7.10 If press-fitted components have to be forced over the running area of the seal, the shaft diameter shall be reduced by 0,2 mm in the running area. The particular rotary shaft lip type seal designed for the shaft may be used without any negative effect on the sealing action. See figure 6.

7.11 When using rubber-covered seals, the outside surface shall be smeared with a suitable lubricant to facilitate entry into the housing. Installing of seal into a housing should be carried out by pressing with uniform speed and pressure into bottom preventing any spring back.

7.12 If elastomeric seals have to be assembled at low temperatures, flexibility of the sealing lip may be restored by placing the seal for 10 to 15 min in a clean, compatible fluid at a temperature not to exceed 50 °C.

7.13 In case of replacement, a new rotary shaft lip type seal shall always be used.

The sealing lip of the new seal shall not be allowed to engage with the previous track of rotation; it shall be shifted to the fluid side. This can be achieved by fitting spacers or exchanging the shaft bushes or the race rings or by varying the depth to which the seal is pressed into the bore.

The sealing surfaces (shaft and bore) shall be thoroughly cleaned, care being taken not to damage them.

8 Identification statement (Reference to this part of ISO 6194)

Use the following statement in test reports, catalogues and sales literature when electing to comply with this part of ISO 6194.

“Storage, handling and installation procedures in accordance with ISO 6194-3, *Rotary shaft lip type seals — Part 3 : Storage, handling and installation*”.

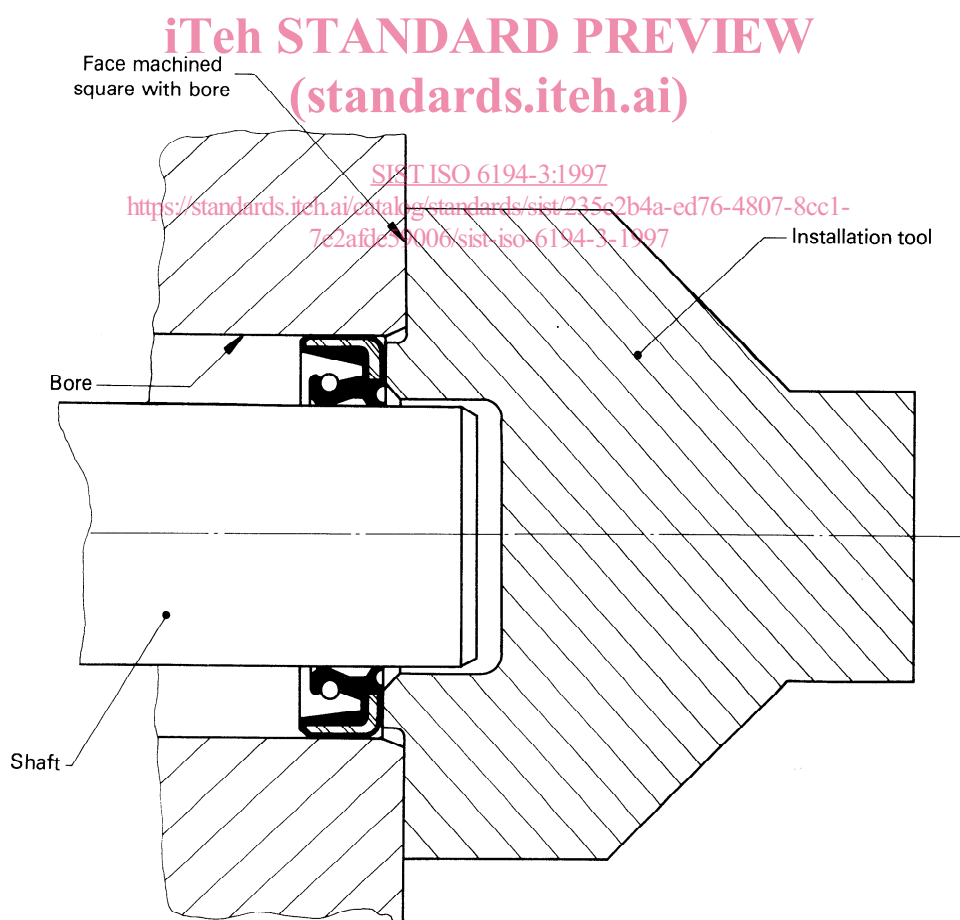

**Figure 1 — Installation of seal —
Through bore : installation tool bottoms on face machined square with bore**

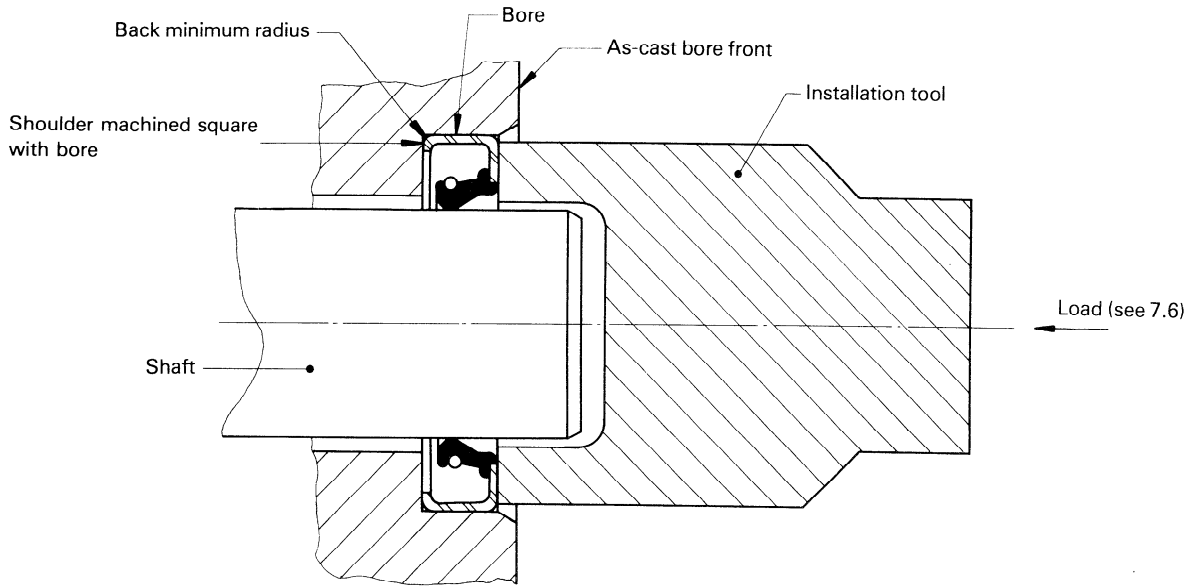

iTeh STANDARD PREVIEW

Figure 2 — Installation of seal — Bottom bore (seal bottoms on machined bore shoulder)

SIST ISO 6194-3:1997
<https://standards.iteh.ai/catalog/standards/sist/235c2b4a-ed76-4807-8cc1-7e2afde59006/sist-iso-6194-3-1997>

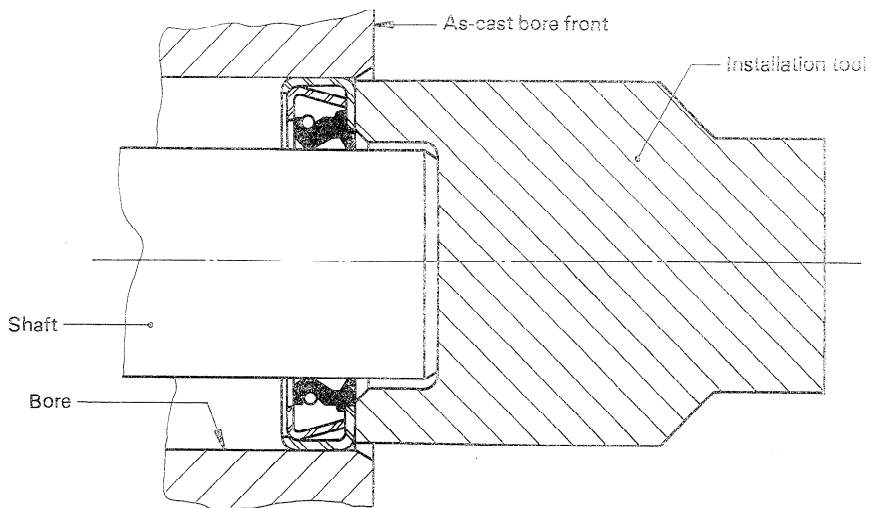
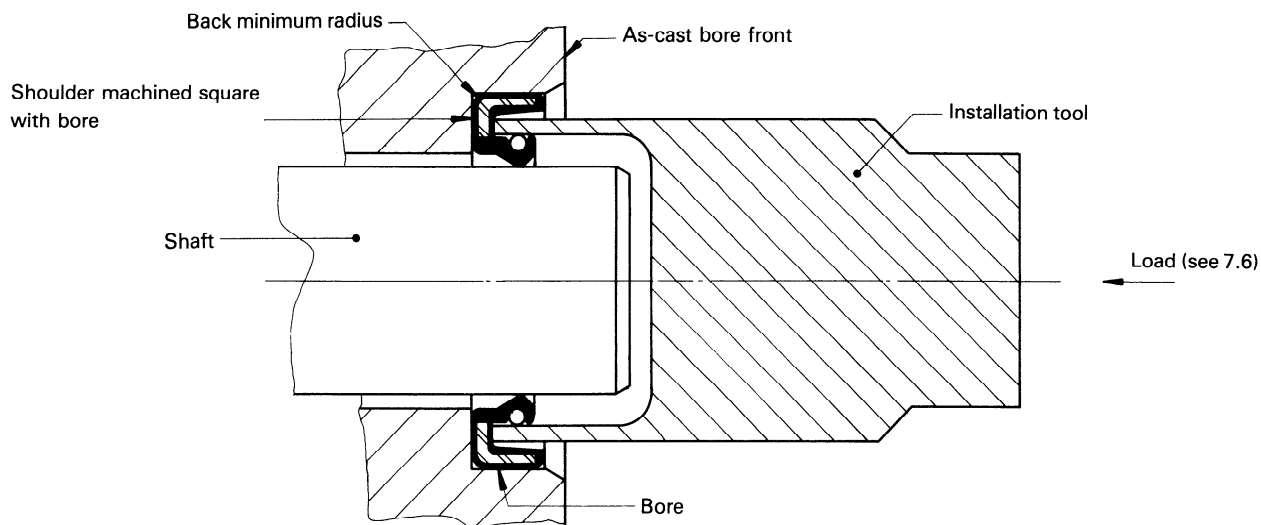
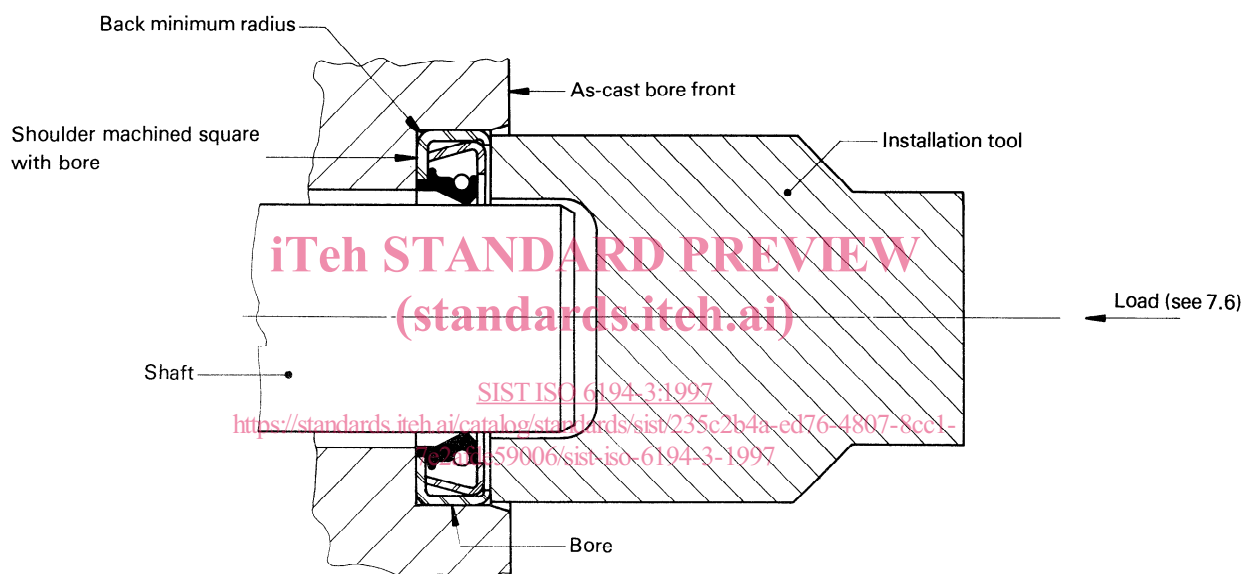

Figure 3 — Installation of seal — Through bore : installation tool bottoms on shaft



a) Bottom bore : seal bottoms on machined bore shoulder



b) Bottom bore : seal bottoms on machined bore shoulder

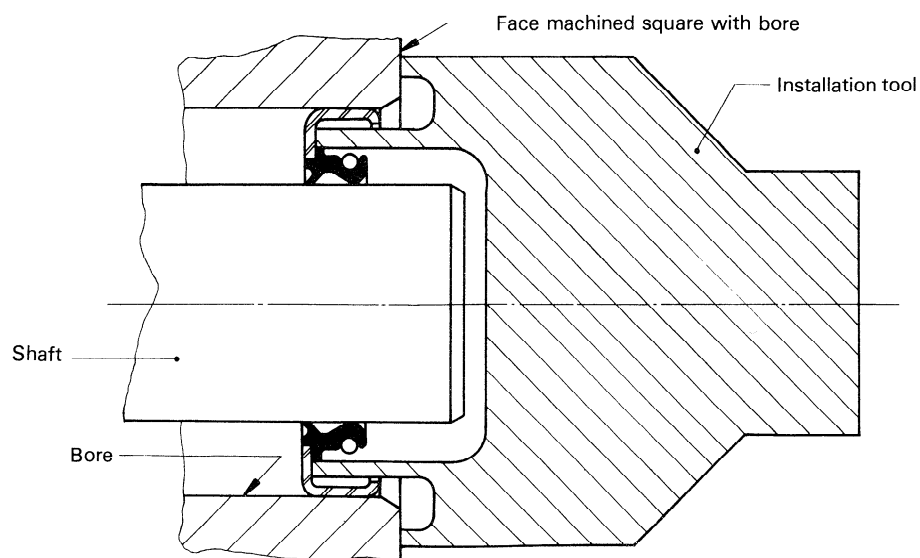

c) Through bore : installation tool bottoms on face machined square with bore

Figure 4 — Illustrated examples of methods of installing a seal into a housing with the seal reversed