International Standard



6195

INTERNATIONAL ORGANIZATION FOR STANDARDIZATION • МЕЖДУНАРОДНАЯ ОРГАНИЗАЦИЯ ПО СТАНДАРТИЗАЦИИ • ORGANISATION INTERNATIONALE DE NORMALISATION

Fluid power systems and components — Cylinders — Housings for rod wiper rings in reciprocating applications — Dimensions and tolerances

Transmissions hydrauliques et pneumatiques — Vérins — Logements de joints racleurs pour tiges de piston à mouvement linéaire — Dimensions et tolérances

First edition — 1986-12-15

ISO 6195:1986
https://standards.iteh.ai/catalog/standards/si/98350a6-9cc-45b1-9d4e-866fd83858ca/iso-6195-1986
iTech STANDARD PREVIEW
(standards.iteh.ai)

UDC 621.643.44 : 62-222

Ref. No. ISO 6195-1986 (E)

Descriptors : hydraulic fluid power, pneumatic fluid power, hydraulic equipment, pneumatic equipment, hydraulic cylinders, pneumatic cylinders, piston-rods, housings, dimensions.

Price based on 6 pages

ITeH STANDARD PREVIEW (standards.iteh.ai)

ISO 6195:1986

<https://standards.iteh.ai/catalog/standards/sist/a83e80a6-e0cc-45b1-9d4e-866fd83858ca/iso-6195-1986>

Foreword

ISO (the International Organization for Standardization) is a worldwide federation of national standards bodies (ISO member bodies). The work of preparing International Standards is normally carried out through ISO technical committees. Each member body interested in a subject for which a technical committee has been established has the right to be represented on that committee. International organizations, governmental and non-governmental, in liaison with ISO, also take part in the work.

Draft International Standards adopted by the technical committees are circulated to the member bodies for approval before their acceptance as International Standards by the ISO Council. They are approved in accordance with ISO procedures requiring at least 75 % approval by the member bodies voting.

International Standard ISO 6195 was prepared by Technical Committee ISO/TC 131, *Fluid power systems*.

Users should note that all International Standards undergo revision from time to time and that any reference made herein to any other International Standard implies its latest edition, unless otherwise stated.

Fluid power systems and components — Cylinders — Housings for rod wiper rings in reciprocating applications — Dimensions and tolerances

0 Introduction

In fluid power systems, power is transmitted and controlled through a fluid (liquid or gas) under pressure within an enclosed circuit. Wiper rings are used to prevent ingress of contaminants and, thereby, protect the seals and bearings within the equipment.

This International Standard is one of a series of standards covering dimensions and tolerances of housings.

1 Scope and field of application

This International Standard lays down the dimensions and tolerances of housings for wiper rings used in reciprocating rod applications for fluid power cylinders. The range of sizes is from 6 mm to 360 mm rod diameters.

It includes the following three housing designs :

- **Type A** : recess housings with undercut or separate cover to retain elastomeric wipers [see figure 1 and table 2 for normal series (preferred)];
- **Type B** : open recess housings for wipers having integral rigid reinforcement, that are a press-fit in the housing (see figure 2 and table 3);
- **Type C** : recess housings with undercut to retain elastomeric wipers (see figure 3 and table 4 for reduced dimension series — recommended for use with cylinders conforming to ISO 6020/2).

This International Standard does not specify the style, configurations, materials or performance rating for the wiper ring.

2 References

ISO 883, *Indexable hardmetal (carbide) inserts with rounded corners, without fixing hole — Dimensions.*

ISO 3320, *Fluid power systems and components — Cylinder bores and piston rod diameters — Metric series.*

ISO 5597, *Hydraulic fluid power — Cylinders — Housings for piston and rod seals in reciprocating applications — Dimensions and tolerances.*¹⁾

ISO 5598, *Fluid power systems and components — Vocabulary.*

ISO 6020/2, *Hydraulic fluid power — Single rod cylinders — Mounting dimensions — 160 bar (16 000 kPa) series — Part 2 : Compact series.*

3 Definitions

For the purposes of this International Standard, the definitions given in ISO 5598 apply.

4 Letter symbols

Letter symbols used in this International Standard are as follows :

d = rod diameter

D_1 = outside diameter of the wiper housing

D_2 = retainer diameter

C = axial length of the lead-in chamfer

L_1 = axial length of the wiper housing

L_2 = maximum length of the wiper

S = $\frac{D_1 - d}{2}$; radial depth (cross-section) of the housing

r = radius

1) At present at the stage of draft. (Revision of ISO 5597-1980.)

5 General

5.1 The wiper ring manufacturer shall be consulted on the suitability of a particular type of wiper ring for the application envisaged.

5.2 All sharp edges and burrs shall be removed from corners of supporting surfaces and rounded, although it should be borne in mind that these surfaces are required to provide maximum support.

6 Dimensions and tolerances

6.1 Type A housing

6.1.1 An illustrated example of type A housings is given in figure 1.

6.1.2 Type A housing dimensions and tolerances shall be selected from table 2.

6.2 Type B housing

6.2.1 An illustrated example of type B housings is given in figure 2.

6.2.2 Type B housing dimensions and tolerances shall be selected from table 3.

6.3 Type C housing

6.3.1 An illustrated example of type C housings for use with cylinders conforming to ISO 6020/2 is given in figure 3.

6.3.2 Type C housing dimensions and tolerances for use with cylinders conforming to ISO 6020/2 shall be selected from table 4.

Bibliography

The following document served as a reference in the preparation of this International Standard and will be helpful when using this International Standard :

ISO 468, *Surface roughness — Parameters, their values and general rules for specifying requirements.*

7 Surface finish

The requirements for the surface finish of the component in contact with the wiper ring are dependent on the application and its life requirement and should be subject to agreement between manufacturer and user.

8 Lead-in chamfer

8.1 Reference shall be made to figures 1 to 3 for the location of the lead-in chamfer, *C*, on the rod end.

8.2 The rod-end chamfer shall make an angle of between 20° and 30° with the axis.

8.3 The length of the rod-end chamfer shall not be less than that shown in table 1.

Table 1 Lead-in chamfer

Dimensions in millimetres

Radial depth of the housing, <i>S</i>	3	4	5	7,5	10
Minimum axial length of lead-in chamfer, <i>C</i>	2	2	2,5	4	5

8.4 The housing lead-in chamfer dimensions for type B housings are given in figure 2.

9 Identification statement (Reference to this International Standard)

Use the following statement in test reports, catalogues, and sales literature when electing to comply with this International Standard :

“Dimensions and tolerances for wiper ring housings, selected in accordance with ISO 6195, *Fluid power systems and components — Cylinders — Housings for rod wiper rings in reciprocating applications — Dimensions and tolerances*”.

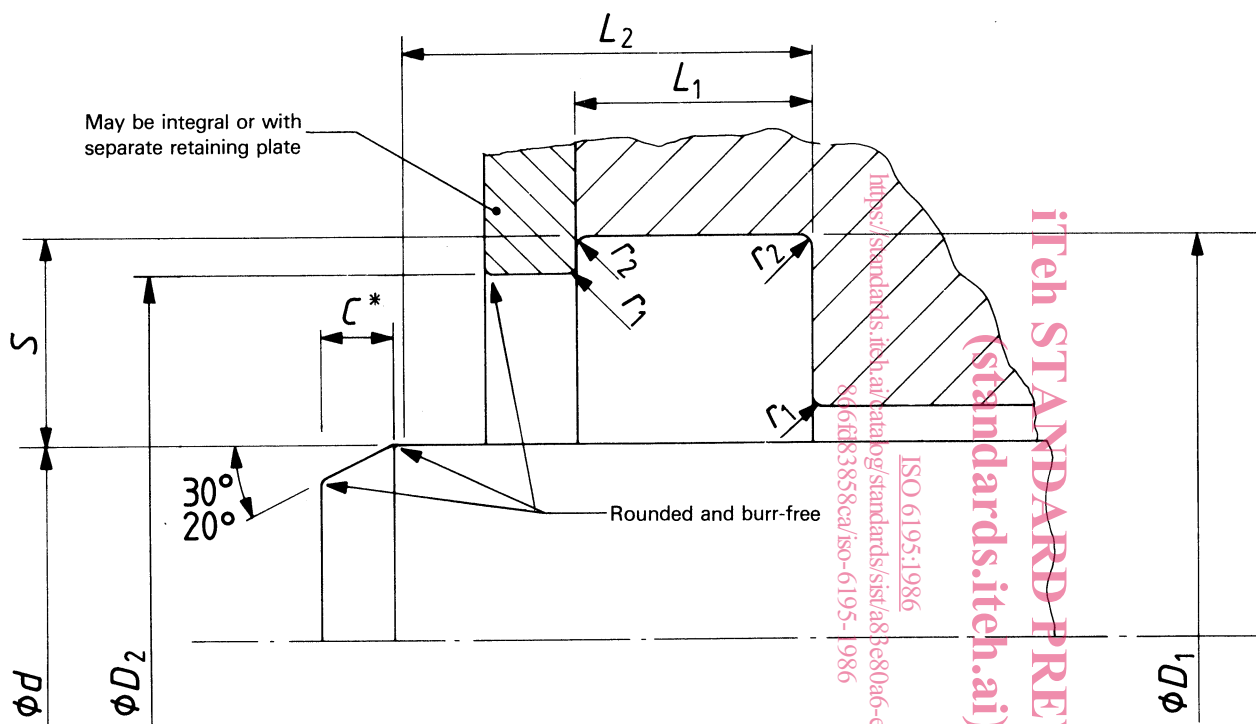

Figure 1 – Example of type A wiper housing

Dimensions in millimetres

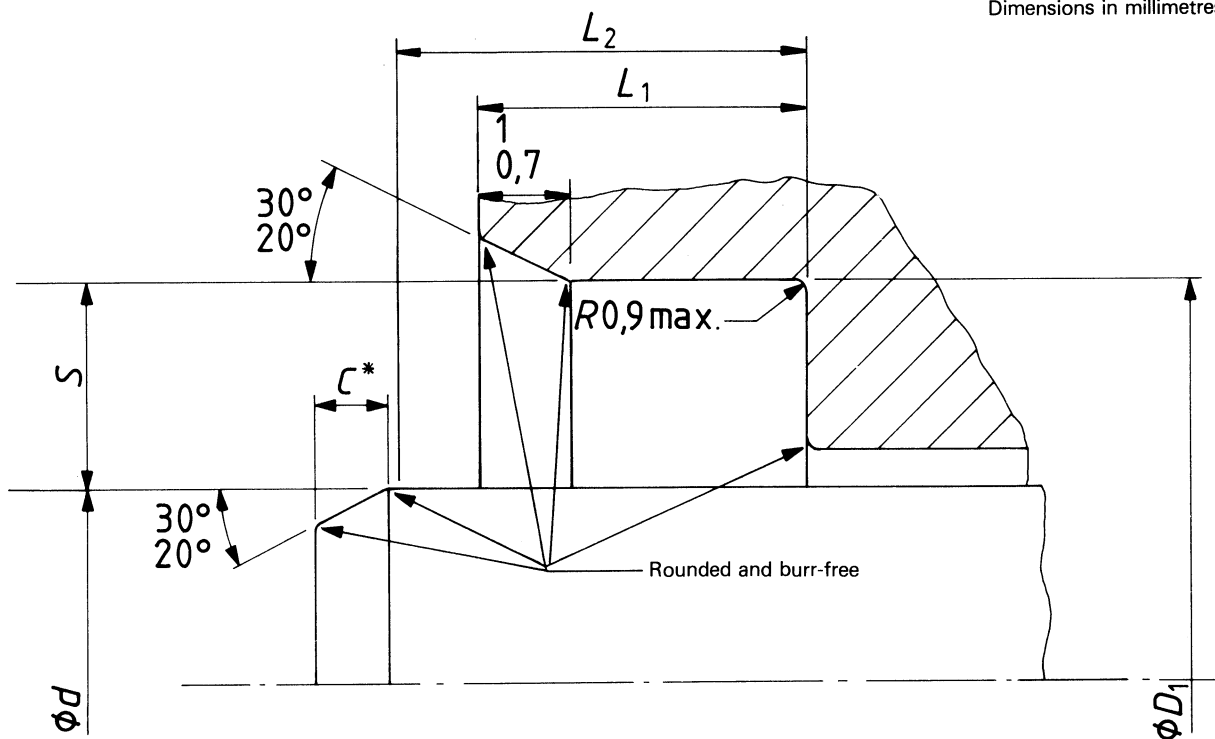

Figure 2 – Example of type B wiper housing

* See table 1.

Table 2 – Dimensions for type A wiper housings

Dimensions in millimetres

Rod diameter ¹⁾ <i>d</i>	Radial depth <i>S</i>	Outside diameter <i>D</i> ₁ H11	Axial length <i>L</i> ₁	Wiper length <i>L</i> ₂ max.	Retainer diameter <i>D</i> ₂ H11	<i>r</i> ₁ max.	<i>r</i> ₂ ²⁾ max.
6 8 10 12 14 16 18 20 22 25 28 32 36 40 45 50	4	14 16 18 20 22 24 26 28 30 33 36 40 44 48 53 58	5 ^{+0.2} ₀	8	11,5 13,5 15,5 17,5 19,5 21,5 23,5 25,5 27,5 30,5 33,5 37,5 41,5 45,5 50,5 55,5	0,3	0,5
56 63 70 80 90	5	66 73 80 90 100	6,3 ^{+0.2} ₀	10	63 70 77 87 97	0,4	
100 110 125 140 160 180 200	7,5	115 125 140 155 175 195 215	9,5 ^{+0.3} ₀	14	110 120 135 150 170 190 210	0,6	0,9
220 250 280 320 360	10	240 270 300 340 380	12,5 ^{+0.3} ₀	18	233,5 263,5 293,5 333,5 373,5	0,8	

1) See ISO 3320 and ISO 5597.

2) These specific dimensions permit the use of tools conforming to ISO 883.

Table 3 – Dimensions for type B wiper housings

Dimensions in millimetres

Rod diameter ¹⁾ <i>d</i>	Radial depth <i>S</i>	Outside diameter <i>D</i> ₁ H8	Axial length <i>L</i> ₁ +0,5 0	Wiper length <i>L</i> ₂ max.
6 8 10	4	14 16 18	5	8
12 14 16 18 20 22 25 28 32 36 40 45 50 56 63 70 80 90	5	22 24 26 28 30 32 35 38 42 46 50 55 60 66 73 80 90 100	7	11
100 110 125 140 160 180 200	7,5	115 125 140 155 175 195 215	9	13
220 250 280 320 360	10	240 270 300 340 380	12	16

1) See ISO 3320 and ISO 5597.

Dimensions in millimetres

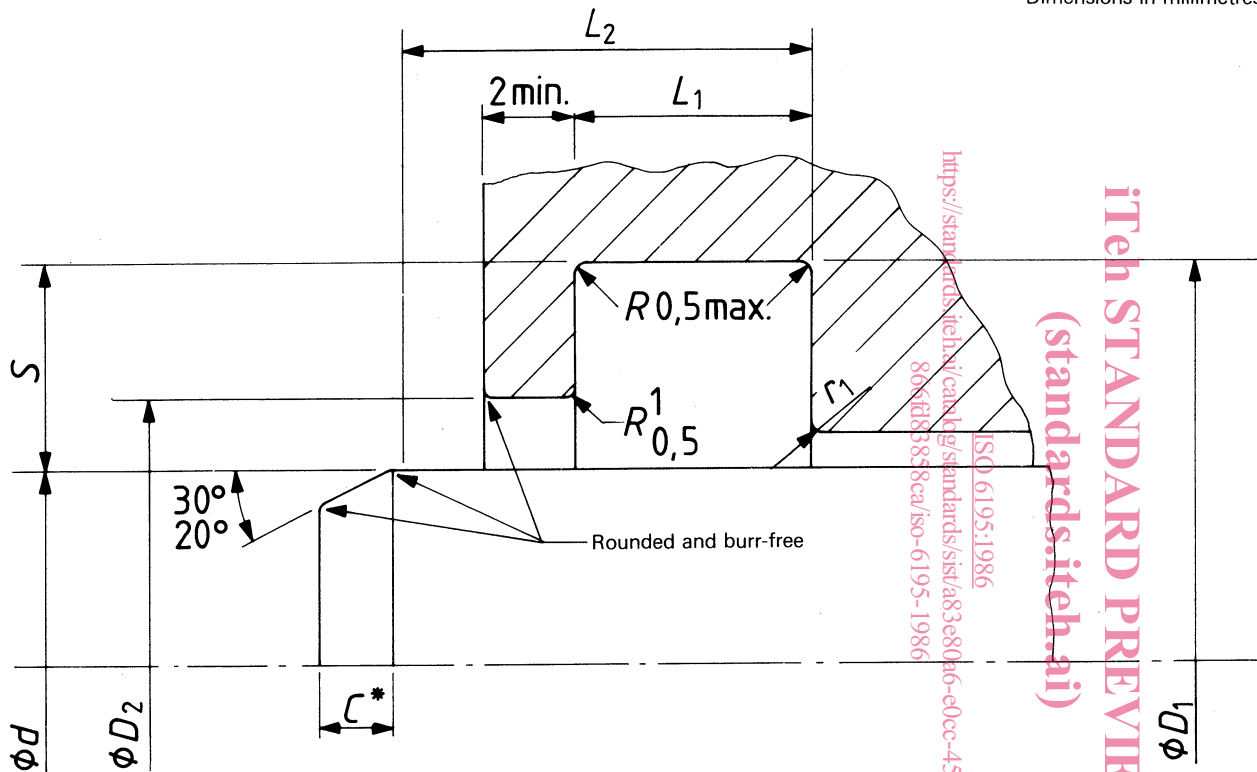

Figure 3 – Example of type C wiper housing
(recommended for use with cylinders conforming to ISO 6020/2)

Table 4 – Dimensions for type C wiper housings
(recommended for use with cylinders conforming to ISO 6020/2)

Dimensions in millimetres

Rod diameter ¹⁾ <i>d</i>	Radial depth <i>S</i>	Outside diameter <i>D</i> ₁ H11	Axial length <i>L</i> ₁	Wiper length <i>L</i> ₂ max.	Retainer diameter <i>D</i> ₂ H11	<i>r</i> ₁ max.
12 14 18 22	3	18 20 24 28	4 ^{+0,2 0}	7	14,5 16,5 20,5 24,5	0,3
28 36 45	4	36 44 53	5 ^{+0,2 0}	8	31 39 48	
56 70 90	5	66 80 100	6 ^{+0,2 0}	9,7	59 73 93	
110 140	7,5	125 155	8,5 ^{+0,3 0}	13,0	114 144	0,4

1) See ISO 6020/2.

* See table 1.